

Operation Manual

Level Plus[®] – LLE

Magnetostrictive Liquid Level Transmitters with Temposonics[®] Technology

- Compact Level Measurement
- Inherent Accuracy +/- 0.5 mm
- No Scheduled Maintenance or Recalibration
- Optional Integral Temperature Measurement



Table of contents

1. Contact information	3
2. Terms and definitions	4
3. Introduction	5
3.1 Purpose and use of this manual	5
3.2 Used symbols and warnings	5
4. Safety instructions	5
4.1 Intended use	5
4.2 Foreseeable misuse	5
4.3 Installation, commissioning and operation	6
5. Product overview	7
5.1 Components	7
5.2 Accuracy	7
5.3 Warranty	7
5.4 Storage	8
5.5 Model number identification	9
5.6 Technical data	11
5.7 Technical drawing	12
6. Installation and mounting	13
6.1 Training	13
6.2 Stilling wells and guide poles	13
6.3 Tools	13
6.4 Installation steps	13
6.5 Mounting	14
7. Electrical connections	15
7.1 Basic information	15
7.2 Safety Recommendation	15
7.3 Grounding	16
7.4 Wiring connections	16
8. Maintenance	17
8.1 Training	17
8.2 Tools	17
8.3 Inspection	17
8.4 Preventative maintenance	17
9. Repair	18
9.1 RMA policy	18
9.2 Training	18
9.3 Troubleshooting	18
10. Spare Parts	19
11. Interface	19
11.1 Analog Output	19
11.2 IO-Link Output	19
11.3 SSI Output	19
11.4 CANopen Output	19

1. Contact information

United States

General

Tel: +1-919-677-0100
Fax: +1-919-677-2343
E-mail: info.us@temposonics.com
<http://www.temposonics.com>

Mailing and shipping address

Temposonics LLC
3001 Sheldon Drive
Cary, North Carolina, 27513, USA

Customer service

Tel: +1-800-633-7609
Fax: +1-800-498-4442
E-mail: info.us@temposonics.com

Technical support and applications

24 Hour Emergency Technical Support
Tel: +1-800-633-7609
E-mail: levelplus@temposonics.com

Germany

General

Tel: +49-2351-9587-0
Fax: +49-2351-56491
E-mail: info.de@temposonics.com
<http://www.temposonics.com>

Mailing and shipping address

Temposonics GmbH & Co. KG
Auf dem Schüffel 9
58513 Lüdenscheid, Germany

Technical support and applications

Tel: +49-2351-9587-0
E-mail: info.de@temposonics.com
<http://www.temposonics.com>

2. Terms and definitions

A

Analog Output

For a sensor with analog output, the measured value is output as an analog voltage signal or current signal.

D

Differential

For differential measurement, the distance between the two position-magnets is output as a value.

I

Interface

Noun; The measurement of the level of one liquid when that liquid is below another liquid.

Interface

Adj.; The Software *Graphical User Interface* (GUI) that allows the user to access software protocols (*HART*®, *DDA*, *MODBUS*).

N

NPT

U.S. standard defining tapered pipe threads used to join pipes and fittings.

S

Specific Gravity

The *density ratio* of a liquid to the density of water at the same conditions.

R

Resolution

The sensor precisely measures time to provide the position measurement. For the analog output the measured time value is converted into an analog voltage signal or current signal using a high-performance Digital to Analog Converter (DAC) having 16 bits of resolution.

3. Introduction

3.1 Purpose and use of this manual

Important:
Before starting the operation of the equipment read this documentation thoroughly and follow the safety information.

The content of this technical documentation and of its various annexes is intended to provide information on mounting, installation and commissioning by qualified automation personnel or instructed service technicians who are familiar with the project planning and dealing with Level Plus liquid level transmitters.

3.2 Used symbols and warnings

Warnings are intended for your personal safety and for avoidance of damage to the described product or connected devices. In this documentation, safety information and warnings to avoid dangers that might affect the life and health of personnel or cause material damage are highlighted by the preceding pictogram, which is defined below.

Symbol	Meaning
NOTICE	This symbol is used to point to situations that may lead to material damage and/or personal injury.

4. Safety instructions

4.1 Intended use

The liquid level transmitter is intended to be used to measure the level of liquid(s) contained by a structure. The product may only be used for the applications defined under item 1 to item 3 and only in conjunction with third-party devices and components recommended or approved by Temposonics. As a prerequisite of proper and safe operation, the product requires correct transport, storage, mounting and commissioning and must be operated with utmost care.

1. Application does not exceed product's performance specification in chapter 5.5.
2. The liquid(s) being measured are compatible with the selected wetted parts of the product.
3. Temposonics floats should be used for proper functionality and safety approval.

4.2 Foreseeable misuse

Foreseeable misuse	Consequence
Wrong sensor connection	Possible damage to electronics See chapter 7 for Electrical Connections
Improper Installation	Physical damage to packaging See chapter 6 for Installation
Process Temperature out of range	Signal Degradation, Possible Damage to Sensor See chapter 5.6 for Specifications
Power Supply out of range	No Communication, Possible Damage to Sensor See chapter 5.6 for Specifications
Process Pressure out of range	Possible Damage to Sensor, See chapter 5.6 for Specifications
Improper Chemical Compatibility	Possible Damage to Sensor, Customer Must Select Wetted Material that is compatible with liquid(s) in tank
Modifying Sensor	Warranty Void, Hazardous Approval Void Customer should contact factory for custom unit
Improper Grounding	Possible Damage to Sensor, Full Protection Compromised, See chapter 7.3 for Grounding
Use of float not sold by Temposonics	Unit may not function correctly or may have erratic output

Fig. 1: Foreseeable misuse

4.3 Installation, commissioning and operation

The liquid level transmitter should be used only in technically safe conditions. To maintain this condition and to ensure safe operation, installation, connection and service, work may be performed only by qualified technical personnel.

If danger of injury to persons or of damage to operating equipment could be caused by sensor failure or malfunction, additional safety measures should be included in the overall automation solution. In the event of trouble, shut down the sensor and protect it against accidental operation.

1. Wear proper personal protection equipment such as hard hat, safety shoes, safety glasses, gloves, and hearing protection.
2. Do not open or dismantle the sensor.
3. Follow the specifications given in the technical documentation.
4. Two (2) individuals are recommended to conduct proper installation, commissioning, and repair of the level transmitter.
5. Protect the sensor against mechanical damage during installation and operation.
6. Do not use damaged products and secure them against unintentional use. Mark damaged products as being defective.
7. Connect the sensor very carefully and pay attention to the polarity of connections. Temposonics recommends to not make connections while power is live.
8. Before turning on power, ensure that nobody's safety is jeopardized by starting level transmitter and/or process.
9. Regularly follow preventative maintenance to prevent safety risks
10. Make sure that no wire strands are loose or sticking out of the terminal block connection which could short and cause a problem.

5. Product overview

The Level Plus LLE satisfies the demand for an accurate and robust liquid level transmitter for general purpose applications. The LLE can provide product level and/or interface level in a compact mechanical design. There is no requirement for scheduled maintenance or recalibration for the expected 10 year life of the sensor. Set it and Forget it.

The LLE liquid level transmitter can be mounted on most tanks offering NPT and RF flanged connections from 3/4 to 6 inches. The LLE also offers a variety of outputs including analog, CANbus, SSI and IO-Link. Included in the model number is the selection of float, cable, and stop collar options. The single model offers everything needed for level measurement in a variety of applications.

Applications

- Hydraulic Reservoir
- Industrial Printers
- Firefighting Airplanes
- Waste Management
- Generators
- Process Tanks
- Skids

Features

- Product and Interface Level
- No scheduled maintenance or recalibration
- Inherent Accuracy +/- 0.5 mm
- IP69K
- 100 g Shock/15 g Vibration

5.1 Components

The Level Plus® LLE liquid level transmitter consists of four main components; a base model, float, adaptor, and optional temperature measurement. Varying the components of the transmitter allows the transmitter to be customized to almost any application.

Base Model

The base model of the LLE consist of the housing, 3/4" NPT threads, M12 connector, and either a 7 mm or 10 mm pipe. The drawing of the base model is shown in section 5.7 Technical Drawing.

Floats

LLE transmitters offer numerous floats for different applications such as stainless steel for both product level and interface level. To be able to accurately detect the interface level there needs to be a difference of at least 0.05 in specific gravities between the product and interface liquids. For detailed information about floats, refer to the 'Accessories Catalog', (Temposonics Part # 551103).

For assistance with selecting a specific float for your application, please contact Technical Support with the following information:

- Specific gravity of liquid(s) being measured
- Process temperature
- Process opening size
- Vessel pressure

Adaptor

The LLE is available with multiple adapters to allow for mounting of the standard 3/4" NPT fitting into larger openings. Available adapters include NPT fittings from 1" to 4", ANSI flanges from 1" to 6", SAE 5 bolt adapters, and custom flanges.

Temperature Measurement

The LLE offers an optional temperature measurement for analog outputs models with a direct RTD output from a PT100 Class A RTD. The RTD is located at 2" from the tip of the pipe for order lengths less than 20" and at 10% of order length for all other lengths.

Accessories

Temposonics also offers a series of displays, housings, converters, and other accessories, please refer to the 'Accessories Catalog', (Part #551103).

5.2 Accuracy

For magnetostrictive transmitters inherent accuracy is measured in terms of non-linearity. Non-linearity is a measurement of any imperfections in the waveguide that are reflected in the linearity of the transmitter's output. Temposonics tolerances reflect a maximum non-linearity of +/- 0.5 mm. Temposonics is able to achieve such strict tolerances by manufacturing all of its own waveguide from a proprietary alloy and testing 100% of all transmitters before shipping.

5.3 Warranty

Important:

Contact Technical Support or Customer Service for assistance if you suspect that the transmitter is not working correctly. Technical support can assist you with troubleshooting, part replacement, and Returned Material Authorization (RMA) information if required.

All Level Plus® transmitters come with a two year limited warranty from the factory shipment date. An additional extended warranty can be purchased. A Return Materials Authorization (RMA) number is required and must accompany any transmitter returns. Any unit that was used in a process must be properly cleaned in accordance with OSHA standards, before it is returned to the factory. A Material Safety Data Sheet (MSDS) must also accompany the transmitter that was used in any process.

The Temposonics obligation is limited to repair or replacement of any defective part of the unit. No warranty can be provided for defects that are due to improper use or above average stress of the product, as well as for wear parts. Under no circumstances will Temposonics accept liability in the event of offense against the warranty rules, no matter if these have been assured or expected, even in case of fault or negligence of the company.

Temposonics explicitly excludes any further warranties. Neither the company's representatives, agents, dealers nor employees are authorized to increase or change the scope of warranty.

5.4 Storage

If storage is required prior to installation, store indoors in a dry environment at ambient temperature range not to exceed $-40\dots+71^{\circ}\text{C}$ ($-40\dots+160^{\circ}\text{F}$).

5.5 Model Number Identification

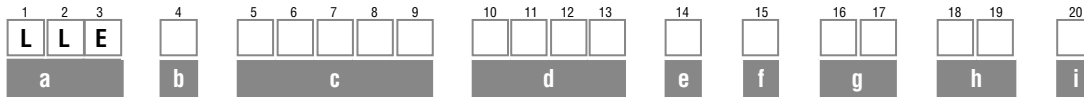

a	Sensor model			
L	L	E	E-Series	

b	Sensors pipe			
G	7 mm 304 SS Pipe			
H	10 mm 316 SS Pipe			

c	Order length				
X	X	X	X	M	0156...2646 mm
X	X	X	X	U	006.2...104.2 in.

d	Output - No Temperature			
V	1	1	0	10...0 Vdc (1 output channel with 1 position magnet)
V	1	2	0	10...0 Vdc (2 output channels with 2 position magnet)
A	1	1	0	20...4 mA (1 output channel with 1 position magnet)
A	1	2	0	20...4 mA (2 output channels with 2 position magnets)
L	0	0	0	IO-Link
S	1	B	0	SSI, 25 bit, Binary, 0.1 mm resolution*
S	1	G	0	SSI, 25 bit, Gray, 0.1 mm resolution*
S	2	B	0	SSI, 24 bit, Binary, 0.1 mm resolution*
S	2	G	0	SSI, 24 bit, Gray, 0.1 mm resolution*
C	3	1	1	CANopen, 1000 kBit/s, 20 um, 1 magnet
C	3	2	1	CANopen, 500 kBit/s, 20 um, 1 magnet
C	3	3	1	CANopen, 250 kBit/s, 20 um, 1 magnet
C	3	4	1	CANopen, 125 kBit/s, 20 um, 1 magnet
C	3	1	2	CANopen, 1000 kBit/s, 20 um, 2 magnets
C	3	2	2	CANopen, 500 kBit/s, 20 um, 2 magnets
C	3	3	2	CANopen, 250 kBit/s, 20 um, 2 magnets
C	3	4	2	CANopen, 125 kBit/s, 20 um, 2 magnets

*/ Measurement direction is set to measure away from housing towards tip.

d	Output			
C	4	1	1	CANopen (bus terminator), 1000 kBit/s, 20 um, 1 magnet
C	4	2	1	CANopen (bus terminator), 500 kBit/s, 20 um, 1 magnet
C	4	3	1	CANopen (bus terminator), 250 kBit/s, 20 um, 1 magnet
C	4	4	1	CANopen (bus terminator), 125 kBit/s, 20 um, 1 magnet
C	4	1	2	CANopen (bus terminator), 1000 kBit/s, 20 um, 2 magnets
C	4	2	2	CANopen (bus terminator), 500 kBit/s, 20 um, 2 magnets
C	4	3	2	CANopen (bus terminator), 250 kBit/s, 20 um, 2 magnets
C	4	4	2	CANopen (bus terminator), 125 kBit/s, 20 um, 2 magnets

d	Output - Temperature (10 mm pipe only)			
V	1	1	T	10...0 Vdc (2 output channel) w/RTD
V	1	2	T	10...0 Vdc (2 output channel) w/RTD
A	1	1	T	20...4 mA (1 output channel) w/RTD
A	1	2	T	20...4 mA (2 output channels) w/RTD

Note: Sensor pipe H = 10 mm is required RTD at 2 in. (50 mm) if length is less than 20 in. (508 mm). RTD at 10% of length for all other lengths.

e	Process Connection Type	
1	NPT	
6	150# RF Flange	
S	SAE	
Z	Custom Flange	
f	See next page	

f	Process Connection Size
A	¾"
B	1"
C	1½"
D	2"
E	2½"
F	3"
G	4"
H	5"
S	SAE 5 bolt
3	SAE-12

g	Float 1
7 0	404834 ** (SG 0.72, 7 mm pipe only)
7 1	404835 ** (SG 0.72, 7 mm pipe only)
7 2	201999 ** (SG 0.7, 7 mm pipe only)
7 3	201611 ** (SG 0.83, 7 mm pipe only)
1 0	561612 (SG 0.61)
1 1	254886 (SG 0.53)
1 2	201120 (SG 0.75)
L 1	251981-2 *** (SG 0.67, 10 mm pipe, stop collar required)
L 2	254526-2 *** (SG 0.68, 10 mm pipe, stop collar required)
L 3	201250-2 *** (SG 0.4, 10 mm pipe, stop collar required)
L 4	252961-2 *** (SG 0.54, 10 mm pipe, stop collar required)
L 5	201232-2 *** (SG 0.7, 10 mm pipe, stop collar required)
L 6	251982-2 *** (SG 0.93, 10 mm pipe, stop collar required)
L 7	254894-2 *** (SG 0.93, 10 mm pipe, stop collar required)
L 8	252962-2 *** (SG 0.93, 10 mm pipe, stop collar required)
L 9	201233-2 *** (SG 0.93, 10 mm pipe, stop collar required)

h	Float 2
X X	None
L 6	251982-2 *** (SG 0.93, 10 mm pipe, stop collar required)
L 7	254894-2 *** (SG 0.93, 10 mm pipe, stop collar required)
L 8	252962-2 *** (SG 0.93, 10 mm pipe, stop collar required)
L 9	201233-2 *** (SG 0.93, 10 mm pipe, stop collar required)

**/ requires G = 7 mm pipe

***/ requires Options B or S with Stop Collar for larger I.D. floats. Not to be used with 7 mm pipe.

i	Options
B	Stop Collar and Cable
C	5 m cable
S	Stop Collar
X	None (o-ring is used to hold float during installation)

Manuals, Software & 3D models available at:
www.temposonics.com

5.6 Technical data

Level Output	
Voltage	0...10 VDC or 10...0 VDC, 0...10 VDC and 10...0 VDC (controller input resistance $R_L > 5 \text{ k}\Omega$)
Current	4...20 mA or 20...4 mA (minimum / maximum load: 0 / 500 Ω)
SSI (Synchronous Serial Interface)	Binary or Gray, 24 or 25 bit
CANbus	CANopen: CIA standard DS 301 V3.0 / encoder profile DS 406 V3.1, CAN System ISO-11898
IO-Link	V1.1, 32 bit signed, COM3 (230.4 kBaud)
Measured value	Product Level and/or Interface Level
Measurement parameters	
Resolution	0.1 mm
Inherent accuracy	$\pm 0.5 \text{ mm}$
Repeatability	$\leq \pm 0.005 \text{ \% F.S.}$ (minimum $\pm 20 \text{ }\mu\text{m}$)
Temperature Output	
Measured Variable	Single point temperature
Accuracy	Class A RTD
Output	PT100 RTD
Operating conditions	
Operating temperature	$-40...+75 \text{ }^\circ\text{C}$ ($-40...+167 \text{ }^\circ\text{F}$)
Humidity	90 % relative humidity, no condensation
Ingress protection ¹	IP67/IP69K (correctly fitted)
Shock test	100 g (single shock) IEC standard 60068-2-27
Vibration test	15 g/10...2000 Hz IEC standard 60068-2-6 (resonance frequencies excluded)
EMC test	Electromagnetic emission according to EN 61000-6-3 Electromagnetic immunity according to EN 61000-6-2 The sensor meets the requirements of the EU directives and is marked with CE
Design/Material	
Sensor electronics housing/Flange	Stainless steel 1.4305 (AISI 303); option: Stainless steel 1.4404 (AISI 316L)
Sensor rod	7 mm (0.28 in.) rod \varnothing : Stainless steel 1.4301 (AISI 304) 10 mm (0.39 in.) rod \varnothing : Stainless steel 1.4404 (AISI 316L)
Stroke length	156...2646 mm (6.2...104.2 in.)
Operating pressure	7 mm (0.28 in.) rod \varnothing : 300 bar (4351 psi), 450 bar (6527 psi) peak 10 mm (0.39 in.) rod \varnothing : 350 bar (5076 psi), 530 bar (7687 psi) peak
Mounting	
Rigid Pipe	NPT ($\frac{3}{4}$ ", 1", 1.5", 2", 2.5", 3", 4"), ANSI RF Flange (2", 3", 4", 5", 6") (150#, 300#, 600#)

Electrical connection See next page

¹/ The IP rating is not part of the UL recognition

Electrical connection	
Connection type	Analog: M12 male connector (5 pin) SSI: M12 male connector (8 pin) IO-Link: M12 male connector (4 pin) CAN: M12 male connector (5 pin)
Operating voltage	+24 VDC (-15 / +20 %); UL recognition requires an approved power supply with energy limitation (UL 61010-1), or Class 2 rating according to the National Electrical Code (USA) / Canadian Electrical Code
Ripple	≤ 0.28 V _{pp}
Current consumption	Analog: 50...140 mA, SSI, CANbus & IO-Link: 60 mA
Dielectric strength	500 VDC (DC ground to machine ground)
Polarity protection	Up to -30 VDC
Overvoltage protection	Up to 36 VDC

5.7 Technical drawing

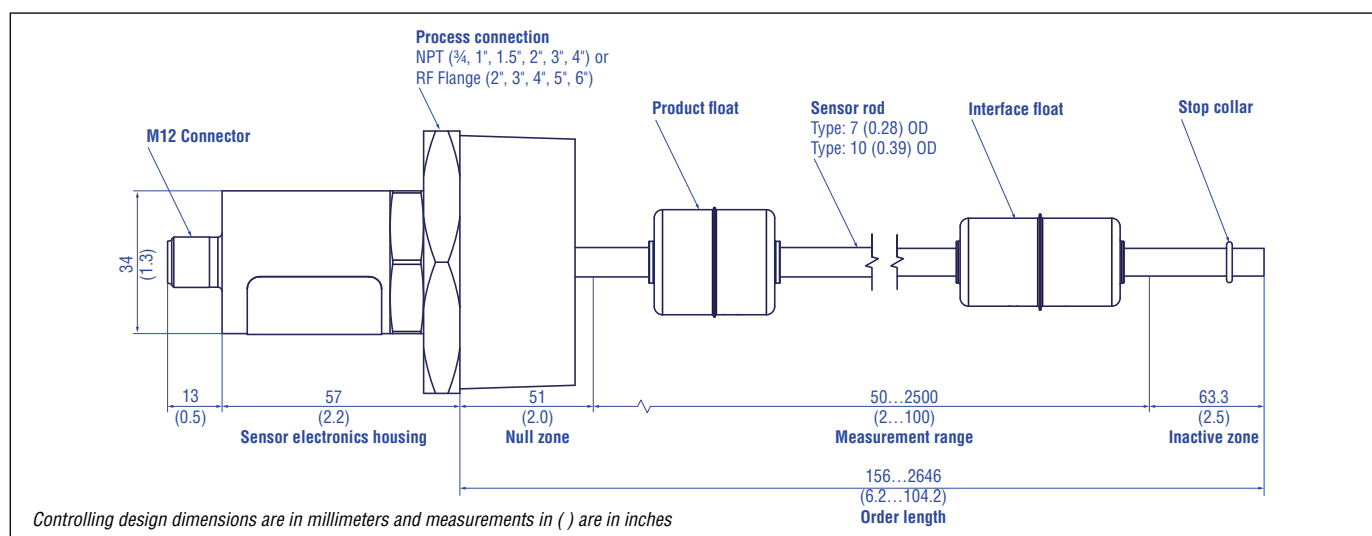

Fig. 2: Technical drawing LLE

6. Installation and mounting

6.1 Training

Installation should only be conducted by qualified service personnel according to local regulations or Temposonics trained service technicians. Temposonics offers web based and in person training for installation, commissioning, maintenance, and repair. Temposonics also offers factory direct services for these same functions. Contact Temposonics to discuss training or factory direct services before starting.

6.2 Stilling wells and guide poles

Level Plus® transmitters can be mounted in slotted or unslotted stilling wells but a slotted stilling well is always preferred. Using a unslotted stilling well will negatively affect performance of any level device as the level in the stilling well can differ from the level in the tank. The Level Plus® transmitter can also be installed to one side of the stilling well to also allow for sampling and manual gauging from the same opening as the automatic tank gauging. Contact technical support for details.

Level Plus® transmitters do not require a stilling well for installation. Our transmitters are installed in numerous tanks without stilling wells with no loss in performance due to our patented flexible waveguide and hose. A stilling well is highly recommended for agitated, turbulent, and/or fast filling tanks.

6.3 Tools

- Adjustable pliers
- Large pipe wrench
- Common head screwdriver, slotted screwdriver

6.4 Installation steps

Caution:

It is recommended that assembly and mounting of this transmitter should not be done alone. To ensure proper and safe assembly of the level transmitter, a minimum of two (2) individuals are recommended. Gloves are also recommended. PPE may be required for work areas such as safety shoes, safety glasses, hard hat, and fire resistant clothing.

1. Consult chapter 4.3 before starting.
2. Perform steps 1-10 in chapter 8.4.1
3. Remove stop collars from rigid pipe.
4. Slide NPT adapter or flange onto rigid pipe and secure the adapter/flange. To prevent damage to rigid pipe keep the adapter/flange supported and towards the end of the level transmitter.
5. Slide the product float onto the rigid pipe. Slide the interface float (optional) onto the rigid pipe. Install stop collar so the magnet of the float is 64 mm (2.5 in.) from the tip of the rigid. Do not drop float(s) or allow them to free fall along the rigid pipe as damage may result.

NOTICE

The bottom stop collar can be removed or adjusted based on the float selected for the application. Please consult the factory for more information.

6. Slide float(s) and adapter or flange assembly back down to the stop collar to prevent them from free falling during installation into the tank. If you are using the o-ring stop collar it will not support the weight of the adapter or flange. Insert the rigid pipe and floats through the tank opening and lower the transmitter float assembly into the tank until it rests on the bottom.
7. Connect the adapter or flange to the mating connector on the tank.
8. Connect the 3/4" NPT (rigid) to the adapter or flange assembly. Tighten the NPT fitting to the adapter or flange. It is recommended to use anti-seize on the connection.
9. Connect cable to connector.
10. Terminate the pigtail cable noting proper wire orientation. Wiring diagram is shown in Section 7.

Consult Section 5.7 Technical Drawing to reference what the finished installation should look like.

6.5 Mounting

The method of mounting the transmitter is dependent on the vessel or tank in which it is being used, and what type of transmitter is being mounted. For model LLE there is a NPT thread mount or flange mount.

NPT Threaded mounting

The level transmitter can be mounted directly to the tank via a NPT threaded fitting, assuming there is a proper threaded connection available as shown in section 5.7. If the float will not fit through the opening, there must be some alternative means to mount the float on the transmitter from inside the vessel; this may require an access port nearby the entry point of the transmitter.

Drilled and tapped flange mounting

The level transmitter can be mounted directly to the tank using a flanged opening. If the float will not fit through the flanged opening when the flange is removed, there must be some alternative means to mount the float on the transmitter from inside the vessel; this may require an access port nearby the entry point of the transmitter.

7. Electrical connections

7.1 Basic information

Placement of installation and cabling have decisive influence on the sensor's electromagnetic compatibility (EMC). Hence correct installation of this active electronic system and the EMC of the entire system must be ensured by using suitable metal connectors, shielded cables and grounding. Overvoltages or faulty connections can damage its electronics despite protection against wrong polarity.

NOTICE

1. Do not mount the sensors in the area of strong magnetic or electric noise fields.
2. Never connect / disconnect the sensor when voltage is applied.

7.2 Safety recommendations

Be sure to:

1. Always follow applicable local and national electrical codes and observe polarity when making electrical connections.
2. Never make electrical connections to the level transmitter with power turned on.
3. Use low-resistance twisted pair and shielded cables. Connect the shield to ground externally via the controller equipment.
4. Keep control and sign leads separate from power cables and sufficiently far away from motor cables, frequency inverters, valve lines, relays, etc.
5. Use only connectors with metal housing and connect the shielding to the connector housing.
6. Keep the connection surface at both shielding ends as large as possible. Connect the cable clamps to function as a ground.
7. Keep all non-shielded leads as short as possible.
8. Keep the earth connection as short as possible with a large cross section. Avoid ground loops.
9. With potential differences between machine and electronics earth connections, no compensating currents are allowed to flow across the cable shielding. Recommendation: Install potential compensating leads with large cross section or use cables with separate double shielding, and connect only one end of the shield.
10. Use only stabilized power supplies in compliance with the specified connecting values

7.3 Grounding

Earth/Machine Ground

The LLE is earth grounded through the process connection to the tank with the assumption that the tank is grounded. If the tank is not grounded then a ground will need to be connected to the housing of the LLE. Without correct grounding the overvoltage protection will be compromised.

Shield Ground

Immunity performance of the sensor from external sources of surge, burst, RF, radiated emissions and other noise is dependent on a proper ground for the shield of the communications cable. The communications cable shield should be of a braided type and connected to the internals.

7.4 Wiring Connections

D34 Analog		
Signal + power supply		
M12 male connector (A-coded)	Pin	Function
 <p>View on sensor</p>	1	+24 VDC (-15 / +20 %)
	2	Output 1
	3	DC Ground (0 V)
	4	Output 2
	5	DC Ground

Fig. 3: D34 Analog

D84 SSI		
Signal + power supply		
M12 male connector (A-coded)	Pin	Function
 <p>View on sensor</p>	1	Clock (+)
	2	Clock (-)
	3	Data (+)
	4	Data (-)
	5	Not connected
	6	Not connected
	7	+24 VDC (-15 / +20 %)
	8	DC Ground (0 V)

Fig. 4: D84 SSI

D44 IO-Link		
Signal + power supply		
M12 A-coded	Pin	Function
 <p>View on sensor</p>	1	+24 VDC (±25 %)
	2	DI/DQ
	3	DC Ground (0 V)
	4	C/Q

Fig. 6: D44 IO-Link

D34 CAN		
Signal + power supply		
M12 male connector (A-coded)	Pin	Function
 <p>View on sensor</p>	1	Shield
	2	+24 VDC (-15 / +20 %)
	3	DC Ground (0 V)
	4	CAN_H
	5	CAN_L

Fig. 5: D34 CAN

T84 Analog + RTD		
Signal + power supply		
M12 male connector (A-coded)	Pin	Function
 <p>View on sensor</p>	1	Clock (+)
	2	Clock (-)
	3	Data (+)
	4	Data (-)
	5	Not connected
	6	Not connected
	7	+24 VDC (-15 / +20 %)
	8	DC Ground (0 V)

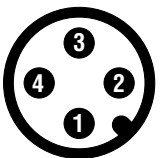
Fig. 7: T84 Analog + RTD

8. Maintenance

8.1 Training

Installation should only be conducted by qualified service personnel according to local regulations or Temposonics trained service technicians. Temposonics offers web based and in person training for installation, commissioning, maintenance, and repair. Temposonics also offers factory direct services for these same functions. Contact Temposonics to discuss training or factory direct services before starting.

8.2 Tools

- Adjustable wrench
- Anti-seize

8.3 Inspection

Below are some standard items that should be inspected on a regular basis to make sure that the level transmitter and surrounding environment are in operating condition.

- There are no visible unauthorized modifications
- Electrical connections are tight
- No obvious damage to cable
- Housing is not damaged or cracked
- No corrosion on visible parts

8.4 Preventative maintenance

The level transmitters do not typically require preventative maintenance but may require preventative maintenance dependent on the application. For general purpose applications where there is no potential for buildup on the pipe and/or float there is no need for preventative maintenance but routine inspection is still suggested. For severe service applications where there is potential for buildup on the pipe and/or float then preventative maintenance is required.

8.4.1 General purpose applications

8.4.1.1

Perform Inspection suggested in chapter 8.3.

8.4.1.2

It is suggested to disconnect the process connection between the tank and the level transmitter and anti-seize or similar lubricant to prevent damage to threads.

8.4.1.3

No additional preventative maintenance is necessary. Preventative maintenance suggested for Severe Service Applications may be performed.

NOTE

It is best to clean the pipe as it is removed from the tank to minimize the amount of product that is removed from the tank. The user should take caution and abide by all regulations so that product is not spilled and the environment is not contaminated.

8.4.2 Severe Service Applications

8.4.2.1

Perform Inspection suggested in chapter 8.3.

8.4.2.2

Disconnect Power.

8.4.2.3

Disconnect process connection from tank. Remove level transmitter from tank.

8.4.2.4

When the bottom of the pipe is reached inspect the float(s).

8.4.2.4.1

If the floats are highly contaminated then remove the assembly from the tank and remove the floats from the pipe.

8.4.2.4.2

If the floats are slightly contaminated then clean the floats without removing the floats from the pipe.

8.4.2.5

Add anti-seize or similar lubricant to connection to prevent damage to threads. Replace rigid pipe and floats in tank.

8.4.2.6

Connect process connection to tank.

8.4.2.7

Connect Power.

8.4.2.8

The process should be carried out regularly until a consistent pattern has been established as to how long the intervals between cleanings should be.

9. Repair

9.1 RMA policy

Important:

Contact Technical Support or Customer Service for assistance if you suspect that the transmitter is not working correctly. Technical support can assist you with troubleshooting, part replacement, and Returned Material Authorization (RMA) information if required.

All Level Plus® transmitters come with a two year limited warranty from the factory shipment date. A Return Materials Authorization (RMA) number is required and must accompany any transmitter returns. Any unit that was used in a process must be properly cleaned in accordance with OSHA standards, before it is returned to the factory. A Material Safety Data Sheet (MSDS) must also accompany the transmitter that was used in any process.

9.2 Training

Repair should only be conducted by qualified service personnel according to local regulations or Temposonics trained service technicians. Temposonics offers web based and in person training for installation, commissioning, maintenance, and repair. Temposonics also offers factory direct services for these same functions. Contact Temposonics to discuss training or factory direct services before starting.

9.3 Troubleshooting

Symptom	Possible cause	Action
No communication with transmitter	No power	Check voltage at transmitter
	Wiring incorrect	Reference wiring connections, chapter 7.4
	Wrong protocol	Confirm software and transmitter are same protocol

Fig. 8: Troubleshooting reference

10. Spare Parts

Below are the spare parts list for the LLE that are included as part of the model number. Please contact Temposonics Technical Support with any questions.

Stop Collar	Part number
7 mm O-ring	562354
10 mm O-ring	562355
7 mm stop collar	562392
10 mm stop collar	562348
Cable	Part number
Analog	370675
IO-Link	370675
CANopen	370675
SSI	370676
Process Connection	Part number
SAE 5 Bolt	404205
1 " NPT	562349-1
1,5 " NPT	562349-2
2 " NPT	562349-3
2,5 " NPT	562349-4
3 " NPT	562349-5
4 " NPT	562349-3
2 " 150# RF Flange	560465-1
3 " 150# RF Flange	560465-2
4 " 150# RF Flange	560465-3
5 " 150# RF Flange	560465-4
6 " 150# RF Flange	560465-5

Fig. 9: Spare parts

11. Interface

11.1 Analog output

The analog output for LLE is either single output or dual output dependent on the order code. The output codes starting with V are voltage outputs and the codes starting with A are current outputs. The first digit is the voltage or current closest to the head and the second is closest to the tip. For example, A010 4..20mA has the 4mA set point closest to the head and 20 mA closest to the tip. The analog output cannot be adjusted.

11.2 IO-Link output

IO-Link is an open standard according to IEC 61131-9. It is a serial, bi-directional point-to-point connection for signal transmission and energy supply. The bi-directional communication enables consistent communication between sensors and the controller as well as consistent diagnostic information down to the sensor level. For additional details on setup please consult the EH IO Link manual 551485 section 5.

The measurement direction of IO Link can be programmed by the customer. The Parameter Measuring Direction, Index 0x73, can be set to False to measure from the housing to the tip of the pipe or True to measure from the tip of the pipe to the housing.

11.3 SSI output

The SSI output is available as either 24 or 25 bit, Binary or Gray code, and 0.1 mm resolution. The measurement direction is set to measure up from the tip of the pipe.

11.4 CANopen output

CANbus (Controller Area Network) is designed for high-speed data exchange at machine level. CAN is a vendor independent open fieldbus system, based on standard ISO 11898. CAN specifies the functional and technical parameters with which the intelligent digital automation devices can be networked via a master-slave serial link by using a communication profile. Protocol architecture of functional and applications data is oriented to the OSI reference model (ISO 7498). Bus technology is administrated and developed by the user organisation CiA (CAN in Automation)

The CANopen output of the LLE is available with or without integral termination, selectable Baud rate of 1000, 500, 250, or 125 kBit/s. The resolution is set at 0.02 mm and the output can be configured for 1 or 2 floats. The measurement direction is set to measure away from the electronic housing and towards the tip of the pipe

UNITED STATES
Temposonics, LLC
Americas & APAC Region
3001 Sheldon Drive
Cary, N.C. 27513
Phone: +1 919 677-0100
E-mail: info.us@temposonics.com

GERMANY
Temposonics
GmbH & Co. KG
EMEA Region & India
Auf dem Schüffel 9
58513 Lüdenscheid
Phone: +49 2351 9587-0
E-mail: info.de@temposonics.com

ITALY
Branch Office
Phone: +39 030 988 3819
E-mail: info.it@temposonics.com

FRANCE
Branch Office
Phone: +33 6 14 060 728
E-mail: info.fr@temposonics.com

UK
Branch Office
Phone: +44 79 21 83 05 86
E-mail: info.uk@temposonics.com

SCANDINAVIA
Branch Office
Phone: +46 70 29 91 281
E-mail: info.sca@temposonics.com

CHINA
Branch Office
Phone: +86 21 3405 7850
E-mail: info.cn@temposonics.com

JAPAN
Branch Office
Phone: +81 3 6416 1063
E-mail: info.jp@temposonics.com

Document Part Number:
552101 Revision C (EN) 06/2024

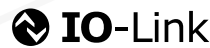

temposonics.com