

Installation Manual

MH-Series Flexible MH

Magnetostrictive Linear Position Sensors



Table of contents

1. Introduction	3
1.1 Purpose and use of this manual	3
1.2 Used symbols and warnings	3
2. Safety instructions	3
2.1 Intended use	3
2.2 Forseeable misuse	3
2.3 Installation, commissioning and operation	4
2.4 Safety instructions for use in explosion-hazardous areas	4
2.5 Warranty	4
2.6 Return	4
3. Identification	5
3.1 Order code of Flexible MH analog	5
3.2 Order code of Flexible MH CANbus	6
3.3 Nameplate	7
3.4 Scope of delivery	7
4. Product description and commissioning	7
4.1 Functionality and system design	7
4.2 Styles and installation of Flexible MH	8
4.3 Replacement of sensor	10
4.3.1 FMH replacement parts	10
4.3.2 FMH replacement steps	11
4.4 Electrical connections	14
4.5 Frequently ordered accessories	15
5. Technical data	16
5.1 Technical data Flexible MH-Series analog	16
5.2 Technical data Flexible MH-Series CANbus	17
6. Appendix	18

1. Introduction

1.1 Purpose and use of this manual

Before starting the operation of Temposonics® position sensors, read this documentation thoroughly and follow the safety information. Keep the manual for future reference!

The content of this technical documentation and of its annex is intended to provide information on mounting, installation and commissioning by qualified automation personnel ¹ or instructed service technicians who are familiar with the project planning and dealing with Temposonics® sensors.

1.2 Used symbols and warnings

Warnings are intended for your personal safety and for avoidance of damage to the described product or connected devices. In this documentation, safety information and warnings to avoid danger that might affect the life and health of operating or service personnel or cause material damage are highlighted by the preceding pictogram which is defined below.

Symbol	Meaning
NOTICE	This symbol is used to point to situations that may lead to material damage, but not to personal injury.

2. Safety instructions

2.1 Intended use

This product may be used only for the applications defined under item 1 and only in conjunction with the third-party devices and components recommended or approved by MTS Sensors. As a prerequisite of proper and safe operation: the product requires correct transport, storage, mounting and commissioning and must be operated with utmost care.

- The sensor systems of all Temposonics® series are intended exclusively for measurement tasks encountered in industrial, commercial and laboratory applications. The sensors are considered as system accessories and must be connected to suitable evaluation electronics, e.g. a PLC, IPC, indicator or other electronic control unit.

^{1/} The term qualified technical personnel characterizes persons who:

- are familiar with the safety concepts of automation technology applicable to the particular project,
- are competent in the field of electromagnetic compatibility (EMC),
- have received adequate training for commissioning and service operations
- are familiar with the operation of the device and know the information required for correct operation provided in the product documentation.

2.2 Forseeable misuse

Foreseeable misuse	Consequence
Wrong sensor connection	The sensor will not work properly or can be damaged
Operate the sensor out of the operating temperature range	No signal output The sensor can be damaged
Power supply is out of the defined range	Signal output is wrong / no signal output / the sensor will be damaged
Position measurement is influenced by an external magnetic field	Signal output is wrong
Cables are damaged	Short circuit – the sensor can be destroyed / sensor does not respond
Spacers are missing / installed in a wrong order	Error in position measurement
Wrong connection of ground / shield	Signal output is disturbed The electronics can be damaged
Use of a magnet that is not specified by MTS Sensors	Error in position measurement

Do not reprocess the sensor afterwards.
→ The sensor might be damaged.

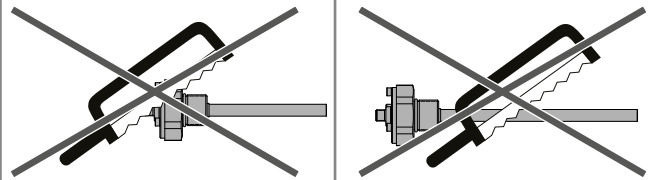

Do not step on the sensor.
→ The sensor might be damaged.

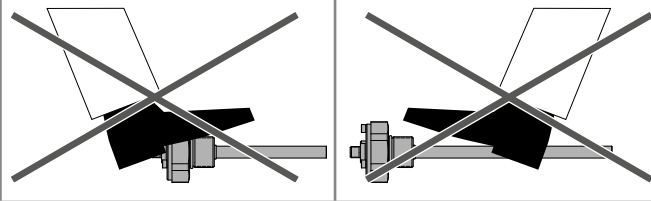

2.3 Installation, commissioning and operation

The position sensors must be used only in technically safe condition. To maintain this condition and to ensure safe operation, installation, connection and service, work may be performed only by qualified technical personnel.

If danger of injury to persons or of damage to operating equipment is caused by sensor failure or malfunction, additional safety measures such as plausibility checks, limit switches, EMERGENCY STOP systems, protective devices etc. are required. In the event of trouble, shut down the sensor and protect it against accidental operation.

Safety instructions for commissioning

To maintain the sensor operability, it is mandatory to follow the instructions given below.

1. Protect the sensor against mechanical damage during installation and operation.
2. Do not open or dismantle the sensor.
3. Connect the sensor very carefully and pay attention to the polarity of connections and power supply.
4. Use only approved power supplies.
5. It is indispensable to ensure that the specified permissible limit values of the sensor for operating voltage, environmental conditions, etc. are met.
6. Check the function of the sensor regularly and provide documentation of the checks.
7. Before applying power, ensure that nobody's safety is jeopardized by starting machines.

2.4 Safety instructions for use in explosion-hazardous areas

The sensor is not suitable for operation in explosion-hazardous areas.

2.5 Warranty

MTS Sensors grants a warranty period for the Temposonics® position sensors and supplied accessories relating to material defects and faults that occur despite correct use in accordance with the intended application². The MTS Sensors obligation is limited to repair or replacement of any defective part of the unit. No warranty can be provided for defects that are due to improper use or above average stress of the product, as well as for wear parts. Under no circumstances will MTS Sensors accept liability in the event of offense against the warranty rules, no matter if these have been assured or expected, even in case of fault or negligence of the company. MTS Sensors explicitly excludes any further warranties. Neither the company's representatives, agents, dealers nor employees are authorized to increase or change the scope of warranty.

2.6 Return

For diagnostic purposes, the sensor can be returned to MTS Sensors. Any shipment cost is the responsibility of the sender². For a corresponding form, see chapter "6. Appendix" on page 18.

^{2/} See also applicable MTS Sensors sales and delivery on www.mtssensors.com

3. Identification

3.1 Order code of Flexible MH analog

1	2	3	4	5	6	7	8	9	10	11	12	13	14
F	M	H						M		3			
a			b	c					d	e	f		

a Sensor model

F	M	H	Flexible MH
---	---	---	-------------

b Design

A	M33 thread flange, flat end plug
B	M33 thread flange, M4 female plug
Z	Base unit (for replacement)

c Stroke length

X	X	X	X	M	0500...5000 mm (20 mm increments)
---	---	---	---	---	-----------------------------------

d Pin assignment

M12 connector (VDC - GND - SIG)

E	M12 connector (E: 2-3-4)
G	M12 connector (G: 1-3-4)
H	M12 connector (H: 1-3-2)

e Operating voltage

3	+12/24 VDC (8...32 VDC)
---	-------------------------

f Output

V	1	1	0.25...4.75 VDC
V	1	2	0.5...4.5 VDC
V	1	3	4.75...0.25 VDC
V	1	4	4.5...0.5 VDC
A	0	1	4...20 mA
A	0	4	20...4 mA

3.2 Order code of Flexible MH CANbus

1	2	3	4	5	6	7	8	9	10	11	12	13	14	15	16	17
F	M	H						M	F	3		0	1			
a			b	c					d	e	f			g	h	

a	Sensor model															
F	M	H	Flexible MH													
b	Design															
A	M33 thread flange, flat end plug															
B	M33 thread flange, M4 female plug															
Z	Base unit (for replacement)															
c	Stroke length															
X	X	X	X	M	0500...5000 mm (20 mm increments)											
d	Pin assignment															
M12 connector (VDC - GND - CAN_HI - CAN_LO)																
F	M12 connector (F: 2-3-4-5)															
e	Operating voltage															
3	+12/24 VDC (8...32 VDC)															
f	Output															
C	0	1	CANopen													
J	0	1	SAE J1939													
g	Baud rate setting															
CANopen																
0	1000 kbit/s															
1	800 kbit/s															
2	500 kbit/s															
3	250 kbit/s (default)															
4	125 kbit/s															
SAE J1939																
3	250 kbit/s (fix setting)															
h	Node ID															
CANopen																
7	F	Node ID (hex): 01...7F (default: 7F)														
SAE J1939																
F	D	Node ID (hex): 01...FD (default: FD)														

3.3 Nameplate

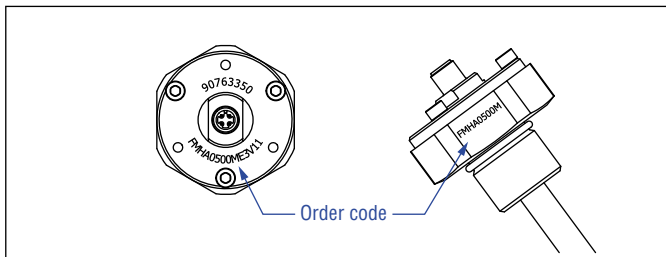

Fig. 1: Example of nameplate

3.4 Scope of delivery

Flexible MH analog/digital:

- Sensor
- O-ring

Flexible MH Sensor Element:

- Sensor element
- Lid
- M5×12 screws (3×)
- M2.5×12 screws (2×)
- Sensor element bracket
- Gasket

4. Product description and commissioning

4.1 Functionality and system design

Product designation

- Position sensor Temposonics® MH-Series

Sensor model

- Temposonics® Flexible MH (rod sensor)

Stroke length

- 500...5000 mm

Output signal

- Analog
- CANopen
- SAE J1939

Principle of operation and system construction

The absolute, linear position sensors provided by MTS Sensors rely on the company's proprietary Temposonics® magnetostrictive technology, which can determine position with a high level of precision and robustness. Each Temposonics® position sensor consists of a ferromagnetic waveguide, a position magnet, a strain pulse converter and supporting electronics. The magnet, connected to the object in motion in the application, generates a magnetic field at its location on the waveguide. A short current pulse is applied to the waveguide. This creates a momentary radial magnetic field and torsional strain on the waveguide. The momentary interaction of the magnetic fields releases a torsional strain pulse that propagates the length of the waveguide. When the ultrasonic wave reaches the end of the waveguide it is converted into an electrical signal. Since the speed of the ultrasonic wave in the waveguide is precisely known, the time required to receive the return signal can be converted into a linear position measurement with both high accuracy and repeatability.

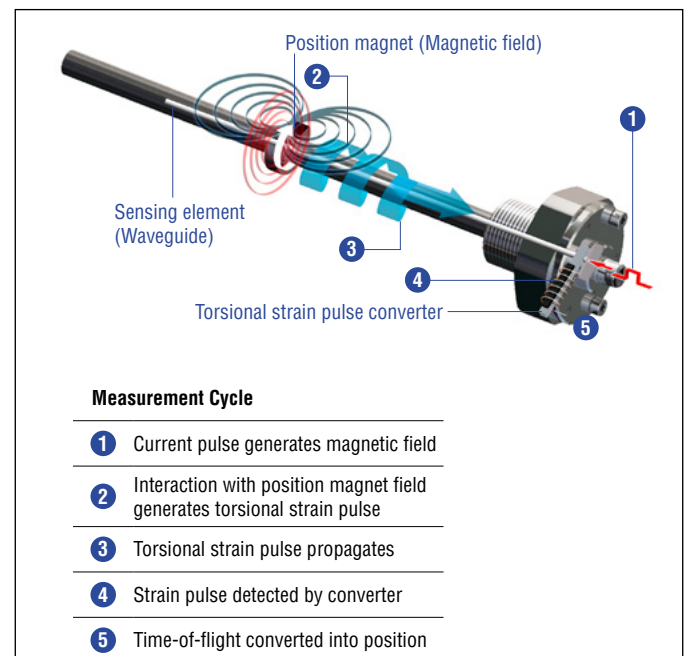

Fig. 2: Principle of operation: Time-based magnetostrictive position sensing principle

Modular mechanical and electronic construction

- The sensor rod protects the inner sensor element.
- The sensor electronics housing, a rugged stainless steel construction, contains the complete electronic interface with active signal conditioning.
- The external position magnet is a permanent magnet. It travels along the sensor rod and triggers the measurement through the sensor rod wall.
- The sensor can be connected directly to a control system. Its electronics generates a strictly position-proportional signal output between zero and end position.

4.2 Styles and installation of Flexible MH

FMH with flat end plug

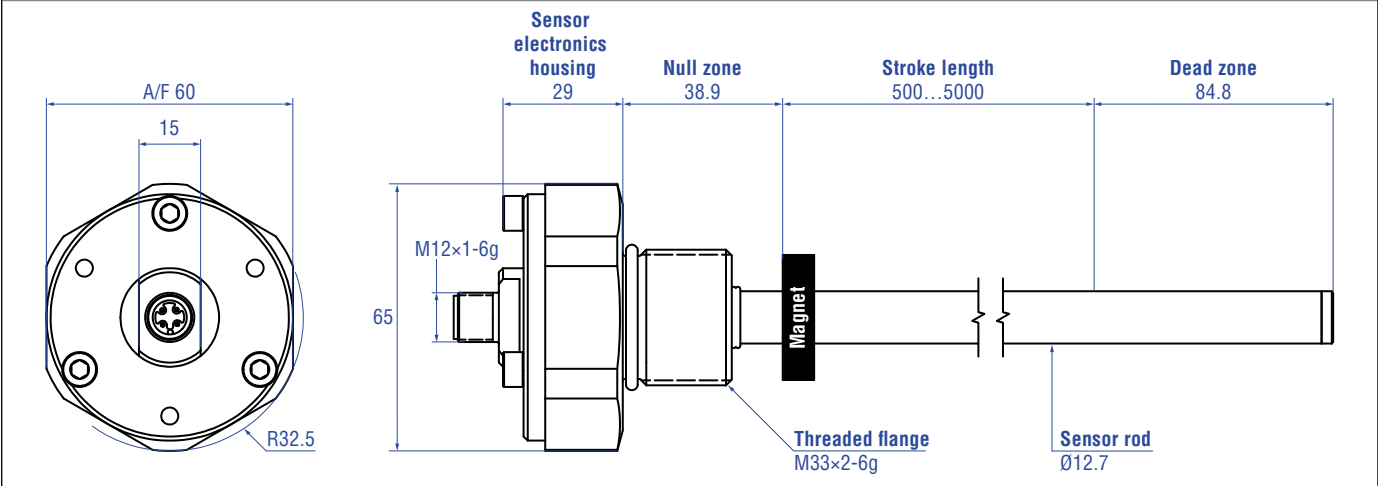

FMH with M4 female thread plug

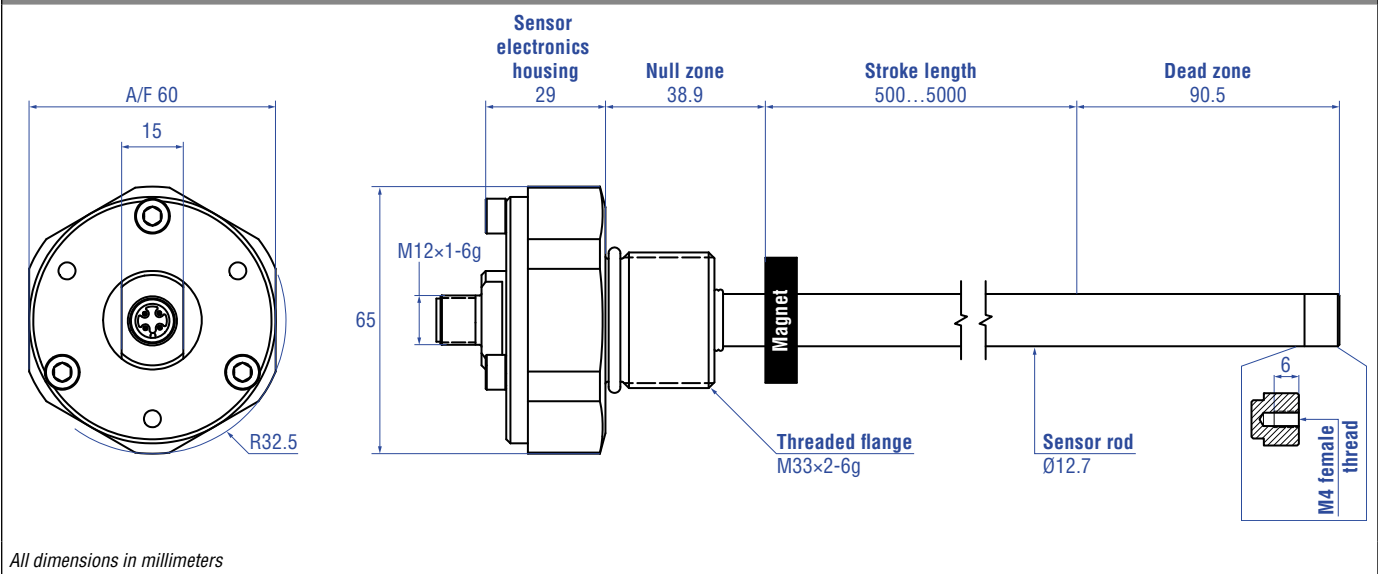

All dimensions in millimeters

Fig. 3: Temposonics® FMH with ring magnet

Installation of a rod-style sensor in a fluid cylinder

The rod-style version has been developed for direct stroke measurement in a fluid cylinder. Mount the sensor via threaded flange. Use non-magnetic material for mounting support.

- Mounted on the face of the piston, the position magnet travels over the rod without touching it and indicates the exact position through the rod wall – independent of the hydraulic fluid.
- The pressure resistant sensor rod is installed into a bore in the piston rod.

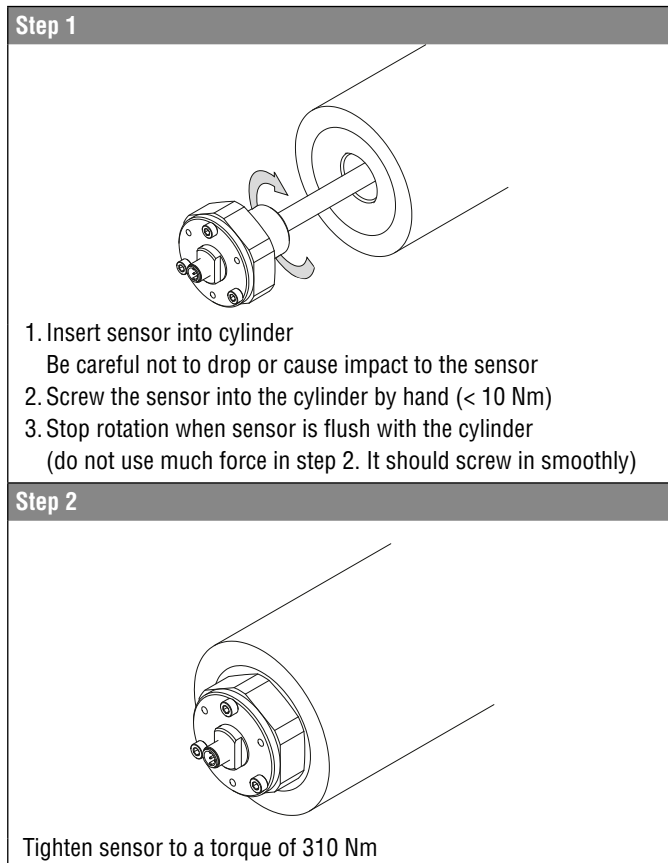

Fig. 5: Sensor in fluid cylinder

Hydraulics sealing

To seal the flange contact surface:

A sealing via an O-ring in the undercut via O-ring 29.6 × 2.9 mm (part no. 561 968)

In the case of threaded flange M33×2-6h, provide a screw hole based on ISO 6149-1. See ISO 6149-1 for further information.

- Note the fastening torque of 310 Nm.
- Seat the flange contact surface completely on the cylinder mounting surface.
- The cylinder manufacturer determines the pressure-resistant gasket (copper gasket, O-ring, etc.).
- The position magnet should not rub on the sensor rod.
- The piston rod drilling (Ø 12.7 mm rod: ≥ Ø 16 mm) depends on the pressure and piston speed.
- Adhere to the information relating to operating pressure.
- Protect the sensor rod against wear.

Cavity Dimensions

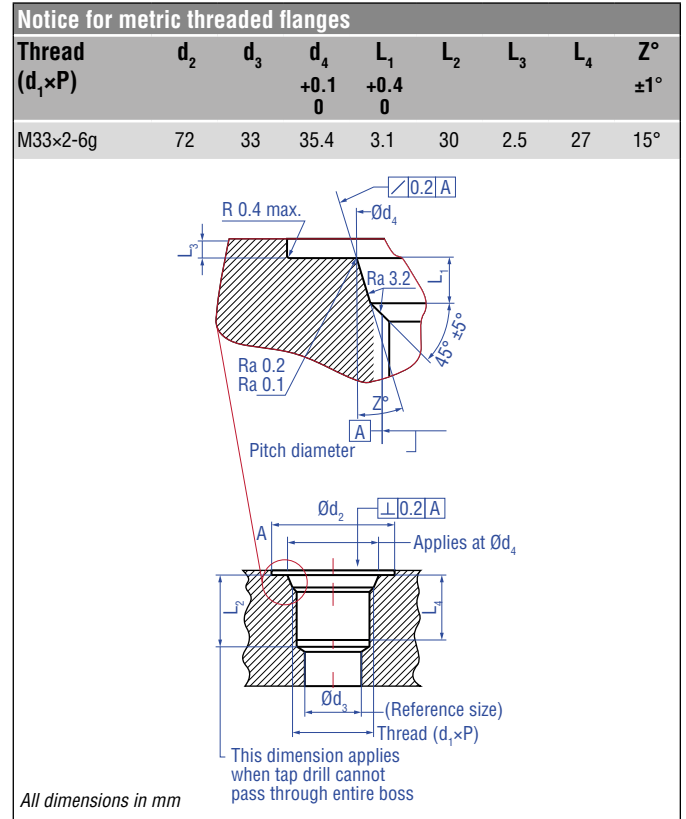

Fig. 4: Cavity dimensions for metric threaded flange M33×2-6h

4.3 Replacement of sensor

The sensor element of the sensor is replaceable. The sensor can be replaced without interrupting the hydraulic circuit.

4.3.1 FMH replacement parts





<p>Lid</p>  <p>Lid (1 ×) Protective cap</p>	
<p>Sensor element</p>  <p>Sensor element (1 ×) Protective cap</p>	
<p>M5×12 screw</p> <p>M5×12 (3 ×) Screws are for mounting lid to housing</p> 	<p>M2×12 screw</p> <p>M2.5×10 (2 ×) Screws are for mounting sensor element to housing</p> 
<p>Bracket</p> <p>Sensor element bracket (1 ×) Mounting sensor element to housing</p> 	<p>Gasket</p> <p>Gasket (1 ×) Replace old gasket with new gasket</p> 
<p>Loctite 242</p> 	

Fig. 6: FMH replacement parts

4.3.2 FMH replacement steps

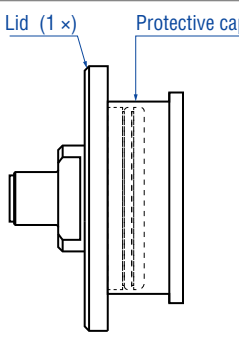
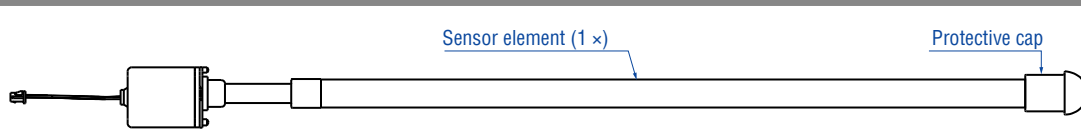
Step 1: Remove endcaps

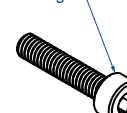
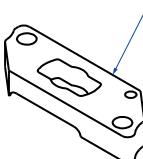
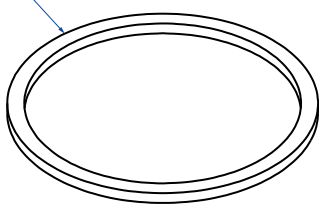

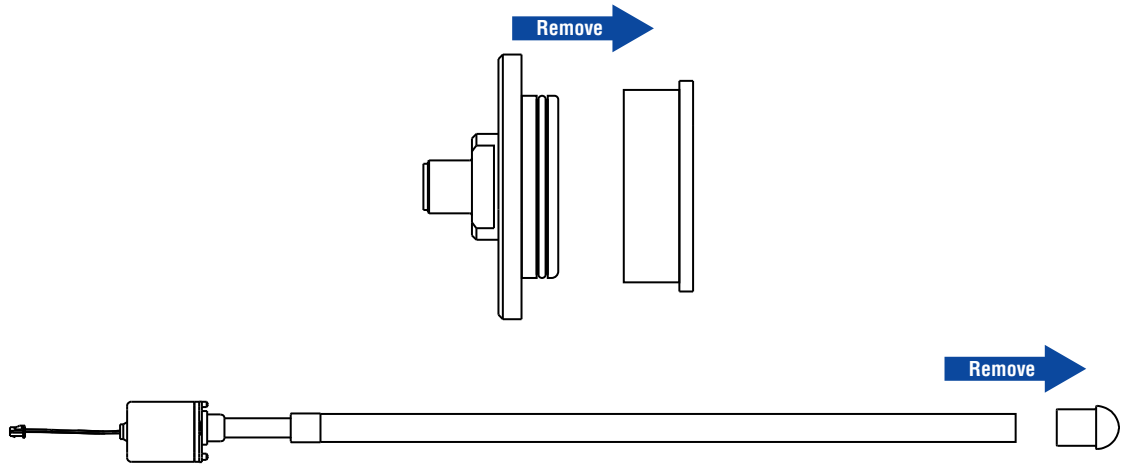
Step 2: Remove lid

Step 2 A

- Remove three screws (M5×12 mm) with 4 mm hex key

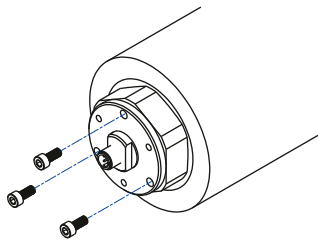

Step 2 B

- Insert screws into threaded holes in lid to aid lid removal

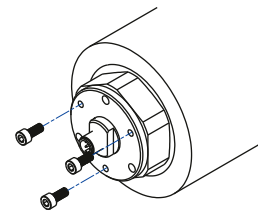

Step 2 C

- Spin screw one in (clockwise) with two rotations
- Spin screw two (any other screw) in (clockwise) with two rotations
- Spin screw three (last, remaining screw) in (clockwise) with two rotations
- Repeat the above steps until all 3 screws are fully inserted

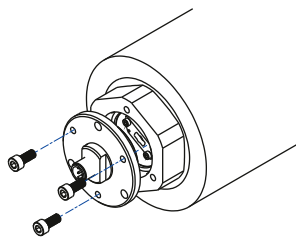

Step 2 D

- Pull lid out from behind flange

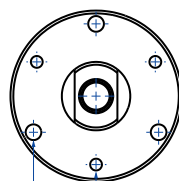
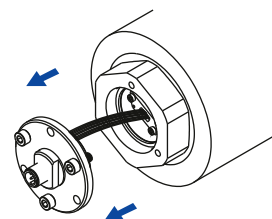

M5×12 threaded holes
are for removing lid
from housing

Holes without threads
are for installing sensor
into cylinder

Fig. 7: FMH replacement steps

Step 3: Remove old sensor element

Step 3 A

- Slowly remove lid entirely
- Be careful not to damage PCB or wires

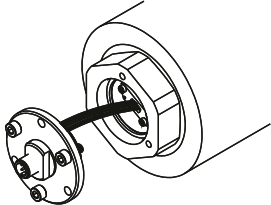

Step 3 B

- Unplug sensor element from PCB in lid
- Pull straight out
- Grip the connector. Do not pull on wires.

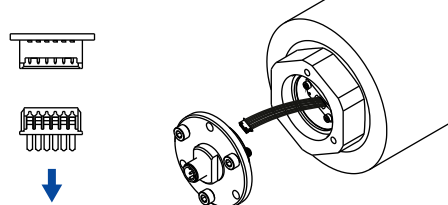

Step 3 C

- Remove the M2.5×10 mm screws with 1.5 mm hex key or #1 Phillips (cross)
- Remove sensor element
- Take care not to bend sensor element (< 200 mm)

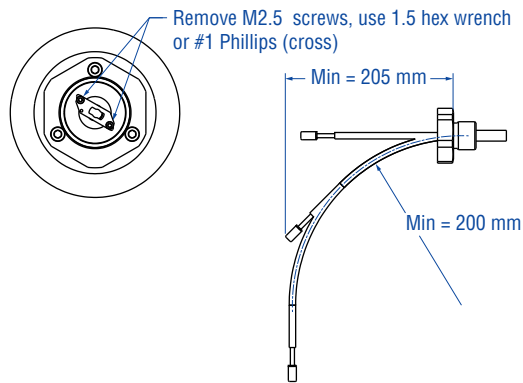

Fig. 8: FMH replacement steps

Step 4: Install new sensor element	
<p>Step 4 A</p> <ul style="list-style-type: none"> • Insert new sensor element into sensor cavity • be careful not to bend the sensor element more than 200 mm radius 	<p>Step 4 B</p> <ul style="list-style-type: none"> • Apply one drop of Loctite 242 to each screw thread • Tighten sensor screws (M2.5×10 mm) to 0.27 Nm (± 0.06 Nm) with 1.5 mm hex key or #1 Phillips (cross) 
<p>Step 4 C</p> <ul style="list-style-type: none"> • Plug wires from sensor element into PCB 	<p>Step 4 D</p> <ul style="list-style-type: none"> • Unscrew all three M5×12 mm screws, with 4 mm hex key from lid save screws for step 5 B 

Fig. 9: FMH replacement steps

Step 5: Install lid	
<p>Step 5 A</p> <ul style="list-style-type: none"> • Insert lid into sensor cavity • Align the lid through holes with the sensor cavity threaded holes 	<p>Step 5 B</p> <ul style="list-style-type: none"> • Apply Loctite 242 to each screw • Insert M5×12 mm screws into lid through holes • Screw all three screws to housing's threads torque M5 screws to 5.9 Nm (± 0.3 Nm) with 4 mm hex key 

Fig. 10: FMH replacement steps

4.4 Electrical connections

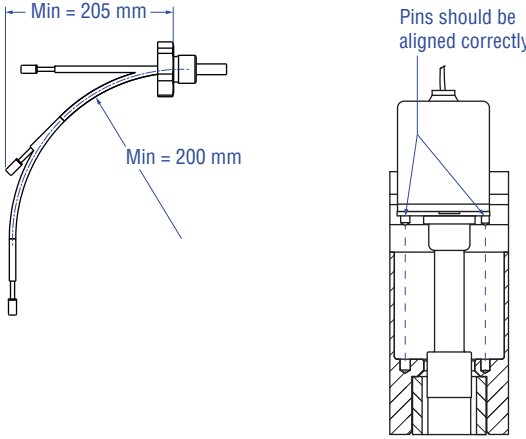
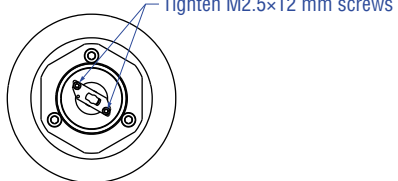
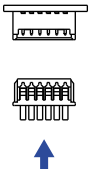
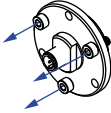
Placement of installation and cabling have decisive influence on the sensor's electromagnetic compatibility (EMC). Hence correct installation of this active electronic system and the EMC of the entire system must be ensured by using suitable metal connectors, shielded cables and grounding. Overvoltages or faulty connections can damage its electronics despite protection against wrong polarity.

NOTICE

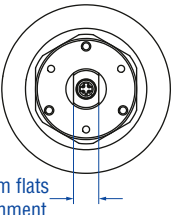
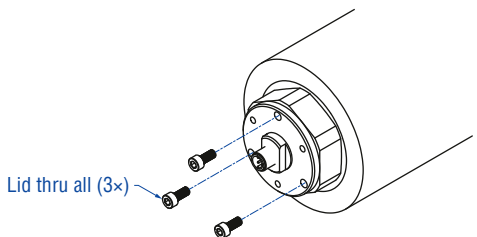
1. Do not mount the sensors in the area of strong magnetic or electric noise fields.
2. Never connect / disconnect the sensor when voltage is applied.

Instructions for connection

- Use low-resistant twisted pair and shielded cables. Connect the shield to ground externally via the controller equipment.
- Keep control and signal leads separate from power cables and sufficiently far away from motor cables, frequency inverters, valve lines, relays, etc..
- Use only connectors with metal housing and connect the shielding to the connector housing.
- Keep the connection surface at both shielding ends as large as possible. Connect the cable clamps to function as a ground.
- Keep all non-shielded leads as short as possible.
- Keep the earth connection as short as possible with a large cross section. Avoid ground loops.
- With potential differences between machine and electronics earth connections, no compensating currents are allowed to flow across the cable shielding.

Recommendation:

Install potential compensating leads with large cross section, or use cables with separate double shielding, and connect only one end of the shield.

- Use only stabilized power supplies in compliance with the specified connecting values.

Analog output				
M12 connector				
Pin	E	G	H	
1	do not connected	VDC	VDC	
2	VDC	do not connected	SIG	
3	GND	GND	GND	
4	SIG	SIG	do not connected	



Fig. 11: Connector wiring analog

CANbus output		
M12 connector		
Pin	F	
1	not connected	
2	VDC	
3	GND	
4	CAN_H	
5	CAN_L	

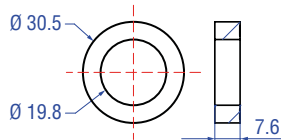

Fig. 12: Connector wiring digital

4.5 Frequently ordered accessories

Position magnets



Ring magnet Part no. 402 316

Material: PA ferrite coated
Weight: ca. 13 g
Operating temperature: -40...+100 °C
Surface pressure: 20 N/mm²

Cord sets and adapter cables

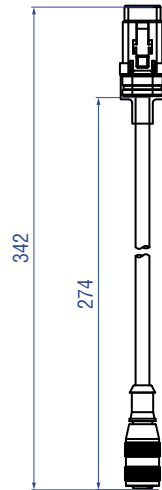

4 pin M12 to DTM06 connector Part no. 254 597

M12 connector: Brass/Nickel
DT connector: DTM06 3 pin
Material: PVC Jacket
Cable length: 275 mm
Cable Ø: 5 mm
Operating temperature:
-40...+105 °C

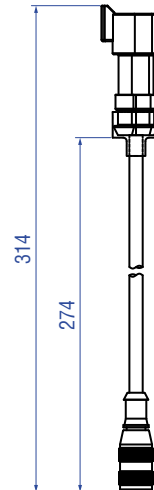

4 pin M12 to DT04 connector Part no. 254 600

M12 connector: Brass/Nickel
DT connector: DT04 3 pin
Material: PVC Jacket
Cable length: 275 mm
Cable Ø: 5 mm
Operating temperature:
-40...+105 °C

Test kits



MH test kit (analog) Part no. 280 618

- Kit includes:**
- 12 VDC battery charger with adapter (EU & UK)
 - Cable with M12 connector
 - Cable with pigtailed wires
 - Carrying case



MH test kit (digital) for US Part no. 253 879

- USB CAN-Modul Kit:
 - USB CAN-Modul
 - USB CAN-Modul Utility CD (driver & manual)
- USB cable
- cable with MTS M12 connector and RS232 connector
- cable with RS232 connector
- carrying case
- 12 VDC power supply



MH test kit (digital) for EU / Asia Part no. 254 267

- USB CAN-Modul Kit:
 - USB CAN-Modul
 - USB CAN-Modul Utility CD (driver & manual)
- USB cable
- cable with MTS M12 connector and RS232 connector
- cable with RS232 connector
- carrying case
- 12 VDC power supply

Controlling design dimensions are in millimeters

5. Technical data

5.1 Technical data Flexible MH-Series analog

Output	
Signal characteristic	Analog output restricted by noise or A/D converter of control unit
Voltage	0.25...4.75 VDC / 0.5...4.5 VDC
Current	4...20 mA
Sample rate	2 ms
Measured value	Position
Measurement parameters	
Resolution	±0.2 mm
Linearity	±0.04 % (F.S.)
Repeatability	±0.005 % (F.S.)
Hysteresis	±0.2 mm
Operating conditions	
Operating temperature	-40...+105 °C
Humidity	90 % rel. humidity, no condensation
Ingress protection	IP67 / IP69K (with appropriate mating connection)
Shock test	IEC 60068-2-27, 100 g (6 ms) single shock, 50 g (11 ms) at 1000 shocks per axis
Vibration test	IEC 60068-2-64, 2 g (5...2000 Hz)
EMC test & evaluation	ISO16750-2:2010 ISO 14982:2009 - Agricultural and forestry machinery ISO 13766:2006 - Earth-moving machinery EN 13309:2010 - Construction machinery RF immunity to 200 V/m per ISO 11452-2/-4
Mounting position	Any
Pressure (according to DIN EN ISO 19879)*	
PN (nominal operating)	350 bar
P _{MAX} (max. overload)	450 bar
P _{STATIC} (proof pressure)	625 bar
Design / Material	
Sensor electronics housing	Stainless steel 1.4305 (AISI 303)
Sensor rod with flange	Stainless steel 1.4306 (AISI 304L)
Stroke length	500...5000 mm
Electrical installation	
Connection type	M12 male plug
Operating voltage	12 VDC (tolerance range 8...32 VDC) 24 VDC (tolerance range 8...32 VDC)
Current consumption	Typ. ≤ 100 mA Typ. ≤ 50 mA
Load (output VDC)	R _L ≥ 10 kΩ R _L ≥ 10 kΩ
Load current (output VDC)	Typ. 1 mA Typ. 1 mA
Load (output mA)	R _L ≤ 250 Ω R _L ≤ 500 Ω
Inrush current	Max. 2.5 A/2 ms Max. 4.5 A/2 ms
Supply voltage ripple	< 1 % _{pp}
Power drain	< 1 W
Over voltage protection (GND-VDC)	Up to +36 VDC
Polarity protection (GND-VDC)	Up to -36 VDC
Insulation Resistance	R ≥ 10 MΩ @ 60 sec
Electric strength	500 VDC (DC GND to chassis GND)

*/ According to calculations under use of the FKM guideline

Cycles	Ø 12.7 mm sensor rod
Dynamic pressure: < 2 × 10 ⁶ pressure cycles	350 bar
Static pressure: < 2 × 10 ⁴ pressure cycles	450 bar
Proof pressure: Maximum 5 minutes testing time for cylinder pressure test	625 bar

5.2 Technical data Flexible MH-Series CANbus

Output

Interface	CANopen / SAE J1939
Sample rate	CANopen: 1 ms; SAE J1939: 20 ms
Measured value	Position

Measurement parameters

Resolution	±0.2 mm
Linearity	±0.04 % (F.S.)
Repeatability	±0.005 % (F.S.)
Hysteresis	±0.2 mm

Operating conditions

Operating temperature	-40...+105 °C
Humidity	90 % rel. humidity, no condensation
Ingress protection	IP67 / IP69K (with appropriate mating connection)
Shock test	IEC 60068-2-27, 100 g (6 ms) single shock, 50 g (11 ms) at 1000 shocks per axis
Vibration test	IEC 60068-2-64, 2 g (5...2000 Hz)
EMC test	ISO16750-2:2010 ISO 14982:2009 - Agricultural and forestry machinery ISO 13766:2006 - Earth-moving machinery EN 13309:2010 - Construction machinery RF immunity to 200 V/m per ISO 11452-2/-4
Mounting position	Any

Pressure (according to DIN EN ISO 19879)*

PN (nominal operating)	350 bar
P _{MAX} (max. overload)	450 bar
P _{STATIC} (proof pressure)	625 bar

Design / Material

Sensor electronics housing	Stainless steel 1.4305 (AISI 303)
Sensor rod with flange	Stainless steel 1.4306 (AISI 304L)
Stroke length	500...5000 mm

Electrical installation

Connection type	M12 male plug	
Operating voltage	12 VDC (tolerance range 8...32 VDC)	24 VDC (tolerance range 8...32 VDC)
Current consumption	Typ. ≤ 100 mA	Typ. ≤ 50 mA
Inrush current	Max. 1.0 A @ 2 ms	Max. 1.5 A @ 2 ms
Bus termination (HI-LO)	120 Ω	
Supply voltage ripple	< 1 % p-p	
Power drain	< 1.5 W	
Over voltage protection (GND-VDC)	Up to +36 VDC	
Polarity protection (GND-VDC)	Up to -36 VDC	
Insulation Resistance	R ≥ 10 MΩ @ 60 sec.	
Electric strength	500 VDC (DC GND to chassis GND)	
Insulation Resistance	R ≥ 10 MΩ @ 60 sec	
Electric strength	500 VDC (DC GND to chassis GND)	

*/ According to calculations under use of the FKM guideline

Cycles	Ø 12.7 mm sensor rod
Dynamic pressure: < 2 × 10 ⁶ pressure cycles	350 bar
Static pressure: < 2 × 10 ⁴ pressure cycles	450 bar
Proof pressure: Maximum 5 minutes testing time for cylinder pressure test	625 bar

6. Appendix

Safety Declaration

Dear Customer,

If you return one or several sensors for checking or repair, we need you to sign a safety declaration. The purpose of this declaration is to ensure that the returned items do not contain residues of harmful substances and / or that people handling these items will not be in danger.

MTS Sensors order number: _____ Sensor type(s): _____

Serial number(s): _____ Sensor length: _____

The sensor has been in contact with the following materials:

Don't specify chemical formulas.
Please include safety data sheets of the substances, if applicable.

In the event of suspected penetration of substances into the sensor,
consult MTS Sensors to determine measures to be taken before
shipment.

Short description of malfunction:

Corporate information

Company: _____

Address: _____

Contact partner

Name: _____

Phone: _____

E-Mail: _____

We hereby certify that the measuring equipment has been cleaned and neutralized.
Equipment handling is safe. Personnel exposure to health risks during transport and repair is excluded.

Stamp

Signature

Date

GERMANY

**MTS Sensor Technologie
GmbH & Co. KG**
Auf dem Schüffel 9
58513 Lüdenscheid, Germany
Tel. +49-23 51-95 87 0
Fax. +49-23 51-5 64 91
info.de@mtssensors.com
www.mtssensors.com

USA

**MTS Systems Corporation
Sensors Division**
3001 Sheldon Drive
Cary, N.C. 27513, USA
Tel. +1 919 677-0100
Fax +1 919 677-0200
info.us@mtssensors.com
www.mtssensors.com



Temposonics

AN AMPHENOL COMPANY

UNITED STATES
Temposonics, LLC
Americas & APAC Region
3001 Sheldon Drive
Cary, N.C. 27513
Phone: +1 919 677-0100
E-mail: info.us@temposonics.com

GERMANY
Temposonics
GmbH & Co. KG
EMEA Region & India
Auf dem Schüffel 9
58513 Lüdenscheid
Phone: +49 2351 9587-0
E-mail: info.de@temposonics.com

ITALY
Branch Office
Phone: +39 030 988 3819
E-mail: info.it@temposonics.com

FRANCE
Branch Office
Phone: +33 6 14 060 728
E-mail: info.fr@temposonics.com

UK
Branch Office
Phone: +44 79 44 15 03 00
E-mail: info.uk@temposonics.com

SCANDINAVIA
Branch Office
Phone: +46 70 29 91 281
E-mail: info.sca@temposonics.com

CHINA
Branch Office
Phone: +86 21 2415 1000 / 2415 1001
E-mail: info.cn@temposonics.com

JAPAN
Branch Office
Phone: +81 3 6416 1063
E-mail: info.jp@temposonics.com

Document Part Number:
551883 Revision B (EN) 02/2020



temposonics.com

© 2021 Temposonics, LLC – all rights reserved. Temposonics, LLC and Temposonics GmbH & Co. KG are subsidiaries of Amphenol Corporation. Except for any third party marks for which attribution is provided herein, the company names and product names used in this document may be the registered trademarks or unregistered trademarks of Temposonics, LLC or Temposonics GmbH & Co. KG. Detailed trademark ownership information is available at www.temposonics.com/trademarkownership.