

Temposonics®

Absolute, Non-Contact Position Sensors

Data Sheet R-Series EtherCAT®

Temposonics® RP and RH
Stroke length 25...7600 mm



Advanced communication
...offers multi-position measurement

- Rugged industrial sensor
- Linear and absolute measurement
- LEDs for sensor diagnostics
- Non-contact sensing with highest durability
- Superior accuracy: Linearity better 0.01 % F. S.
- Resolution 1 μm
- Repeatability 0.001 % F.S.
- Direct EtherCAT output
- Position + velocity with 5 magnets
- Positions with up to 20 magnets

Discontinued

Sensor diagnostic display

Integrated LEDs (green/red) provide basic visual feedback for normal sensor operation and troubleshooting.

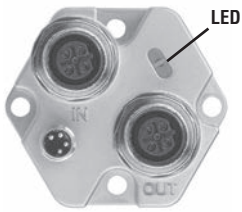

Green	Red	Description
Flashing	OFF	Normal function
Flashing	ON	Magnet not detected or Wrong quantity of magnets
Further diagnostic features programmable.		

Characteristics of the EtherCAT® sensor

Sensor's output

- Position as an absolute value
- Velocity and direction of the drive
- Diagnostics (Status information)
- Error status (e.g. of magnet)

The EtherCAT® Interface

The sensor fulfils the requirements of the EtherCAT field-bus and can be connected as a slave to this bus system. EtherCAT is an open field-bus system which is based on the EtherNet technology (IEEE 802.3) with a high data rate, short response time and a good real-time performance, it is standardized in the IEC/PAS 62407 and it is part of the ISO 15745-4. The integration in the IEC 61158, IEC 61784 and IEC 61800-7 is in the way.

It is very easy to implement the Temposonics® sensor with the EtherCAT interface into an EtherCAT field-bus system. The System-Manager (e.g. TwinCAT from Beckhoff) gets all the parameters of the sensor from the XML-file, which part of the delivery. There are no settings on the sensor.

The measurement can be synchronized by the PLC, by switching the sensor to the “distributed clock mode” (1 - 5 magnets only).

Operation mode

There are two versions available:

E101 1 - 5 magnet measurement

Measuring in parallel the position and velocities of up to 5 magnets.

The data telegram contains from each magnet:

- Position (32 bit)
- Velocity (32 bit)
- Long status information (16 bit)

E102 1 - 20 multi-magnet measurement

Measuring in parallel the positions of up to 20 magnets.

The data telegram contains from each magnet:

- Position (32 bit)
- Velocity (32 bit)
- Long status information (16 bit)

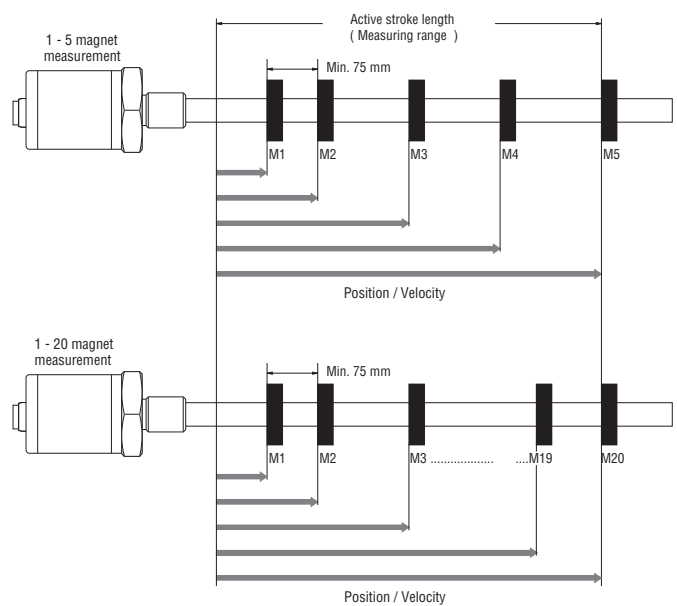

Technical Data
Input

Measured value	Position / Velocity 1 - 5 magnet measurement option 1 - 20 magnet measurement
Stroke length	Profile 25...5000 mm / Rod 25...7600 mm

Output

Output signal	EtherCAT Ethernet Control Automation Technology
Data format	EtherCAT 100 Base-Tx, Fast Ethernet
Data transmission rate	100 MBit/s max.

Accuracy

Resolution	
- Position	1...1000 µm selectable
- Speed	1 µm/s (Quality rating) adjustable according to velocity and stroke length
Linearity	< ± 0.01 % F.S. (Minimum ± 50 µm) Option internal linearization Linearity tolerance: <u>RP/RH</u> < 300 mm: typ. ± 15 µm, max. ± 25 µm, > 300...600 mm: typ. ± 20 µm, max. ± 30 µm > 600...1200 mm: typ. ± 30 µm, max. ± 50 µm <u>RP</u> 1200...3000 mm: typ. ± 45 µm, max. ± 90 µm, 3...5 m: typ. ± 85 µm, max. ± 150 µm
Repeatability	< ± 0.001 % F.S. (Minimum ± 2.5 µm)
Cycle time	Stroke length dependent
Data transmission rate	≤ 10 kHz (oversampling is active while the scanning cycle is shorter than the measuring cycle.)
Temperature coefficient	< 15 ppm/°C
Ripple	< 5 µm
Hysteresis	< 4 µm

Operating conditions

Magnet speed	any
Operating temperature	-40 °C...+75 °C
Dew point, humidity	90 % rel. humidity, no condensation
Ingress protection ¹	Profile: IP65, Rod: IP67, if mating connector is correctly fitted, RS: IP69K
Shock test	100 g single hit, IEC-Standard 60068-2-27
Vibration test	15 g / 10 - 2000 Hz, IEC-Standard 60068-2-6
Standards, EMC test	Electromagnetic emission EN 61000-6-4 Electromagnetic immunity EN 61000-6-2 EN 61000-4-2/3/4/6, Level 3/4, Criterion A, CE-qualified

Design, Material

Diagnostic display	LEDs beside connector
<u>Profile model:</u>	
Sensor head	Aluminum
Sensor stroke	Aluminum
Position magnet	Magnet slider or removable U-magnet
<u>Rod model:</u>	
Sensor head	Aluminum
Rod with flange	Stainless steel 1.4301 / AISI 304
Pressure rating	350 bar, (700 bar peak) for hydraulic rod
Position magnet	Ring magnets, U-magnets

Installation

Mounting position	any orientation
Profile	Movable mounting clamps or T-slot nuts M5 in base channel
U-magnet, removable	Mounting plate and screws from antimagnetical material
Rod	Threaded flange M18 x 1.5 or ¾" -16 UNF-3A, Hex nut M18
Position magnet	Mounting plate and screws from antimagnetical material

Electrical connection

Connection type	2 x 4 pin connector M12-D
Supply voltage	24 VDC (-15 / +20 %); UL Recognition requires an approved power supply with energy limitation (UL 61010-1), or Class 2 rating according to the National Electrical Code (USA) / Canadian Electrical Code.
- Polarity protection	up to -30 VDC
- Overvoltage protection	up to 36 VDC
Current drain	80 mA typical
Ripple	≤ 0.28 Vpp
Electric strength	500 VDC (DC ground to machine ground)

¹ The IP rating is not part of the UL recognition

Stable profile design

Temposonics® RP offers modular construction, flexible mounting configurations and easy installation. Position measurement is contactless via two versions of permanent magnets.

- A sliding magnet running in profile housing rails. Connection with the mobile machine part is via a ball jointed arm to taking up axial forces.
- A floating magnet, mounted directly on the moving machine part, travels over the profile at a low distance. Its air-gap allows the correction of small misalignments at installation.

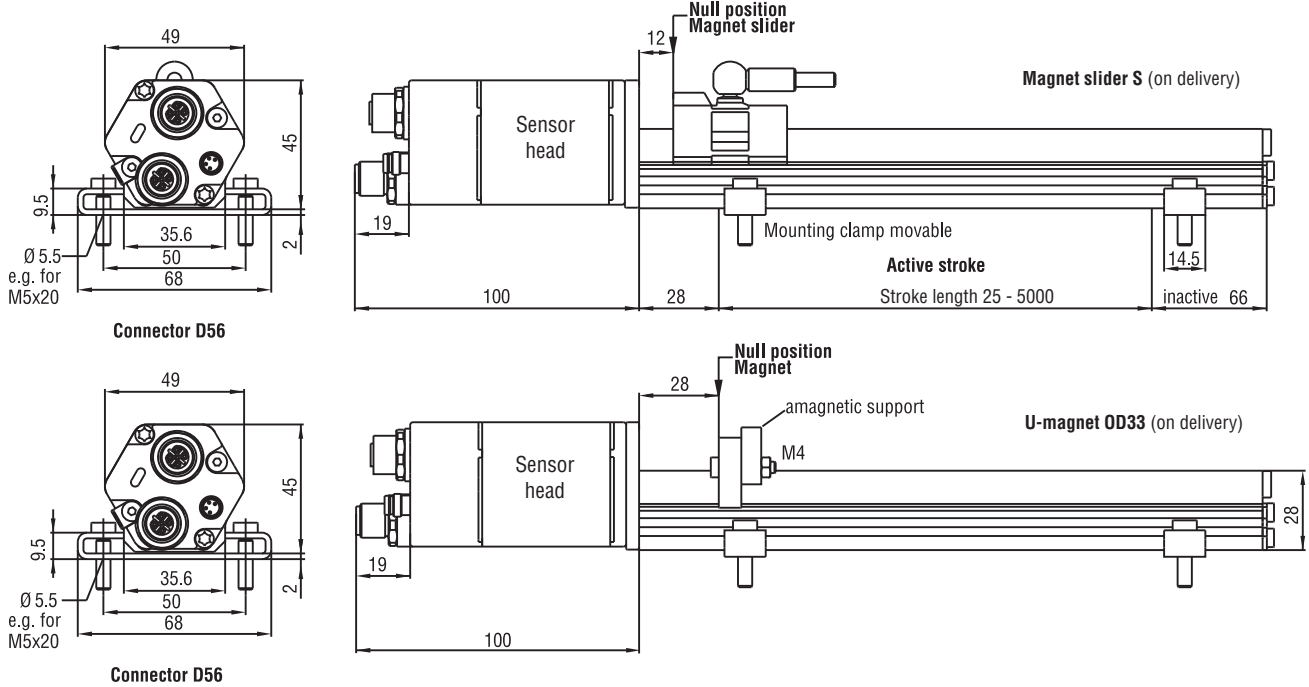

Connection	BUS In / Out	Pin	Cable	Function
View Connector side Sensor		1	yellow	Tx+
		2	white	Rx+
		3	orange	Tx-
		4	blue	Rx-

Input voltage	Pin	Cable	Function
	1	brown	+24 VDC (-15 / +20 %)
	2	white	do not connect
	3	blue	0 V (GND)
	4	black	do not connect

All dimensions in mm

Standard position magnet included in delivery (see chapter accessories)

Position magnets

Magnet slider S (part no. 252 182)
 Magnet slider V (part no. 252 184)
 U-magnet OD33 (part no. 251 416-2)

Connection types

Cable connector (part no. 530 066)
 Cable connector (part no. 530 064)
 4 pin Bus cable connector (part no. 370 523)

High pressure rod design

Temposonics® RH with a pressureresistant stainless steel flange and sensing rod is suitable for use in hydraulic cylinders and externally in all applications where space is a problem. Position measurement is via ring or U-magnets travelling along the sensing rod without any mechanical contact.

Advantage...

the completely operable sensor cartridge can be replaced for servicing easily without opening the fluid circuit.

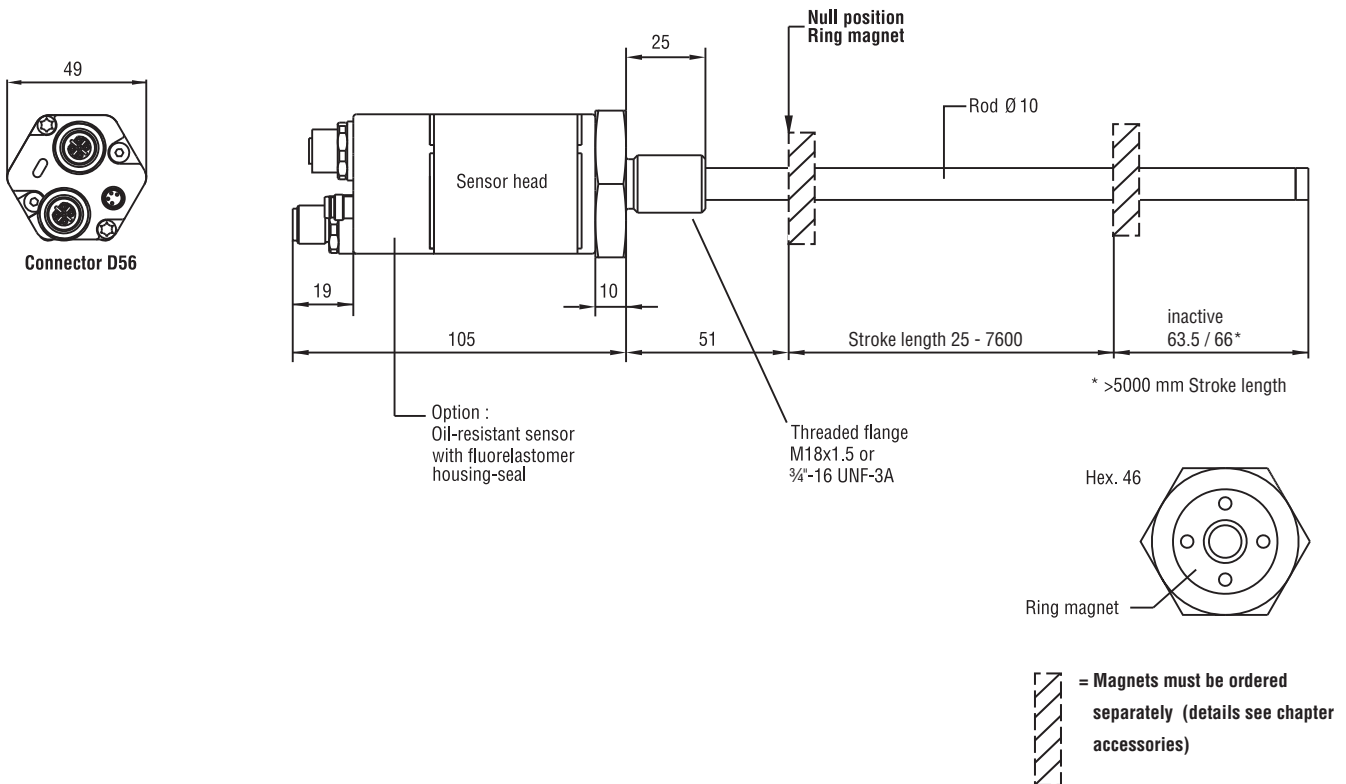

Standard position magnets (not included in delivery, please order separatley)

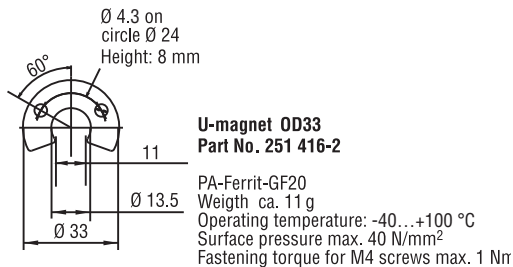
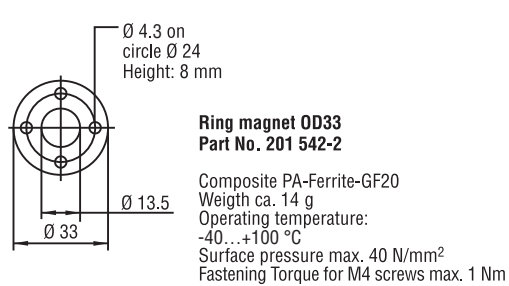

All dimensions in mm

Standard position magnet not included in delivery (see chapter accessories)

Position magnets

Ring magnet OD33 (part no. 201 542-2)
Ring magnet OD25,4 (part no. 400 533)
U-magnet OD33 (part no. 251 416-2)

Connection types

Cable connector (part no. 530 066)
Cable connector (part no. 530 064)
4 pin Bus cable connector (part no. 370 523)

Temposonics®	
Sensor model	M
RP - Profile	
RH - Rod	
Design	E
Profile Temposonics® RP:	
S - Magnet slider, joint at top	
V - Magnet slider, joint at front	
G - Magnet slider, joint at top, backlash free	
M - U-magnet, OD33	
Rod Temposonics® RH:	
M - Flange M18 x 1.5 (Standard)	
V - Flange M18 x 1.5 (Fluorelastomer housing-seal)	
D - Flange M18 x 1.5 with bushing on rod end	
R - Flange M18 x 1.5 with thread M4 at rod end	
J - Flange M22 x 1.5, rod Ø 12.7 mm, 800 bar	
S - Flange ¾" - 16 UNF - 3A	
Stroke length	Z
Profile - 0025...5000 mm	
Rod - 0025...7600 mm	
Standard: See chart	
Other length upon request.	
Connection type	
D56 - 2 x 4 pin female receptacle M12-D, 1 x 4 pin male receptacle M8	
Supply voltage	
1 - + 24 VDC	
A - +24 VDC, high vibration resistant (stroke length 25...2000 mm)	
Output	
E 101 - EtherCAT, Single- and multi-position measurement, 1 - 5 positions and velocity distributed clock mode selectable	
E 102 - EtherCAT, Single- and multi-position measurement, 1 - 20 positions and velocity	
E 103 - EtherCAT, Single-position measurement, position and velocity, internal linearization	
Magnet number for Multi-Position measurement*	
Z02 - Z20 = 2 - 20 pcs	
<i>*Note: Please specify magnet numbers for your sensing application and order separately</i>	

Included in delivery profile model:

Sensor, magnet slider or U-magnet, 2 mounting clamps up to 1250 mm stroke + 1 clamp for every additional 500 mm.
Installation guide + CD-ROM (XML-File).

Included in delivery rod model:

Sensor and O-ring. Installation guide + CD-ROM (XML-File).
Magnets must be ordered separately. Use signed magnets for sensors w/LCO

Stroke Length Standard RP	
Stroke length	Ordering steps
≤ 500 mm	25 mm
500...2500 mm	50 mm
2500...5000 mm	100 mm

Stroke Length Standard RH	
Stroke length	Ordering steps
< 500 mm	5 mm
500...750 mm	10 mm
750...1000 mm	25 mm
1000...2500 mm	50 mm
2500...5000 mm	100 mm
> 5000 mm	250 mm

Accessories page 67 and following.

UNITED STATES
Temposonics, LLC
Americas & APAC Region
3001 Sheldon Drive
Cary, N.C. 27513
Phone: +1 919 677-0100
E-mail: info.us@temposonics.com

GERMANY
Temposonics
GmbH & Co. KG
EMEA Region & India
Auf dem Schüffel 9
58513 Lüdenscheid
Phone: +49 2351 9587-0
E-mail: info.de@temposonics.com

ITALY
Branch Office
Phone: +39 030 988 3819
E-mail: info.it@temposonics.com

FRANCE
Branch Office
Phone: +33 6 14 060 728
E-mail: info.fr@temposonics.com

UK
Branch Office
Phone: +44 79 44 15 03 00
E-mail: info.uk@temposonics.com

SCANDINAVIA
Branch Office
Phone: +46 70 29 91 281
E-mail: info.sca@temposonics.com

CHINA
Branch Office
Phone: +86 21 2415 1000 / 2415 1001
E-mail: info.cn@temposonics.com

JAPAN
Branch Office
Phone: +81 3 6416 1063
E-mail: info.jp@temposonics.com

Document part number:
Extract from 551303 Revision J (EN) 10/2019



temposonics.com