

## Accessories Catalog

### Level Plus<sup>®</sup>

Magnetostrictive Liquid Level Transmitters with Temposonics<sup>®</sup> Technology

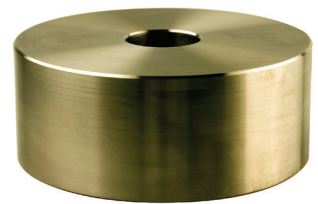

## Table of contents

|   |           |
|---|-----------|
| <b>1. Floats</b> .....                        | <b>3</b>  |
| 1.1 Standard product floats .....             | 3         |
| 1.2 LLE product floats .....                  | 5         |
| 1.3 RefineME interface floats .....           | 6         |
| 1.4 SoClean and LLH sanitary floats .....     | 7         |
| 1.5 RefineME FEP floats .....                 | 9         |
| 1.6 Long-gauge floats .....                   | 10        |
| <b>2. Process meters and enclosures</b> ..... | <b>11</b> |
| 2.1 Analog process meters .....               | 11        |
| 2.2 Modbus process meters .....               | 12        |
| 2.3 Process meter enclosures .....            | 12        |
| 2.4 Modbus Terminals .....                    | 12        |
| <b>3. Programming and hardware</b> .....      | <b>13</b> |
| 3.1 Setup software .....                      | 13        |
| 3.2 Hardware .....                            | 13        |
| <b>4. Magnet and weight assemblies</b> .....  | <b>14</b> |

## Introduction

Temposonics offers a variety of floats to meet your application needs. Our floats come in a variety of sizes from 18 mm (0.71 in.) up to 203 mm (8 in.) in diameter. Float materials are available in stainless steel, FEP, Titanium, Nickel Alloy C-276 and Buna-N.

Product viscosity, specific gravity, and temperature can vary widely in a process or tank gauging application. Because of these variables and others, such as tank pressure and corrosiveness, no one float can meet all requirements. Therefore, a variety of float styles are available and we will assist you in choosing the one that best meets your requirements.

When choosing a float for your application, Temposonics recommends you choose one that has a specific gravity of at least 0.05 less than that of the measured liquid. For interface measurement, a minimum of 0.05 specific gravity differential is recommended between upper and lower liquids. Temposonics also offers a variety of meters, housings, and calibration equipment as accessories to our transmitter range. Meters are available for analog, and Modbus outputs.







For more information, please contact the Temposonics' applications department or go to [www.temposonics.com](http://www.temposonics.com) for more information.

## 1. Floats

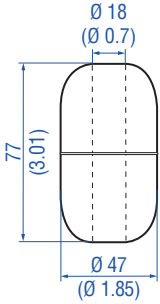
### 1.1 Standard product floats

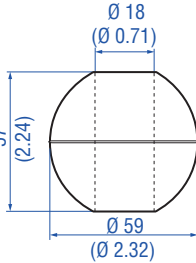

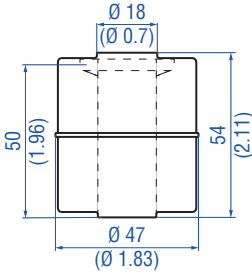

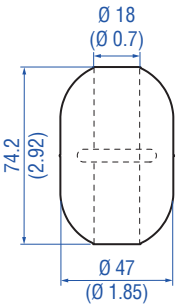
#### General notes:

1. Be sure that the float specific gravity is at least 0.05 less than that of the measured liquid as a safety margin at ambient temperature.
2. For interface measurement: A minimum of 0.05 specific gravity differential is required between the upper and lower liquids.
3. When the magnet is not shown, the magnet is positioned at the center line of float.
4. Drawings contained in this document are for reference only. Contact the factory for engineering drawings.
5. \* Standard float that can be expedited

| Photo   | Drawing   | Max Pipe OD | Pressure              | Temperature        | Magnet offset | Specific gravity | Material           | Part no.   |
|---|---|-------------|-----------------------|--------------------|---------------|------------------|--------------------|------------|
|    |   | 5/8"        | 29.3 bar<br>(425 psi) | 149 °C<br>(300 °F) | No            | 0.67             | Stainless steel    | 251 981-2* |
|   |   |             |                       |                    |               | 0.71             | Nickel Alloy C-276 | 251 981-4  |
|  |  | 5/8"        | 22.4 bar<br>(325 psi) | 149 °C<br>(300 °F) | No            | 0.49             | Stainless steel    | 251 387-2  |
|  |  | 5/8"        | 4 bar<br>(60 psi)     | 149 °C<br>(300 °F) | Yes           | 0.6              | Stainless steel    | 201 605-2* |
|  |  | 5/8"        | 69 bar<br>(1000 psi)  | 149 °C<br>(300 °F) | No            | 0.68             | Stainless steel    | 254 526-2* |

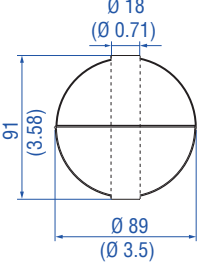
Controlling design dimensions are in millimeters and measurements in ( ) are in inches

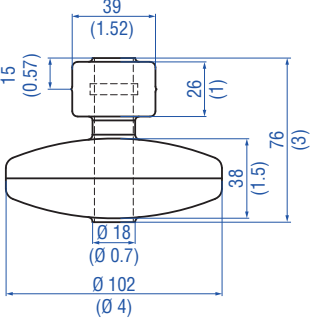

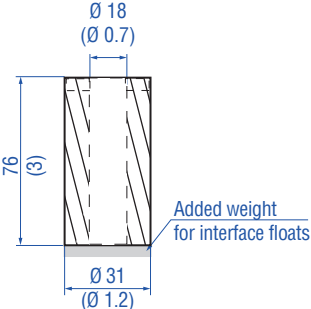



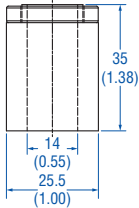

Accessories for liquid level transmitters  
Catalog

| Photo   | Drawing   | Max Pipe OD | Pressure              | Temperature        | Magnet offset | Specific gravity | Material        | Part no.          |
|---|---|-------------|-----------------------|--------------------|---------------|------------------|-----------------|-------------------|
|    |    | 5/8"        | 22.4 bar<br>(325 psi) | 149 °C<br>(300 °F) | No            | 0.45             | Stainless steel | <b>251 469-2</b>  |
|     |    | 5/8"        | 8.6 bar<br>(125 psi)  | 149 °C<br>(300 °F) | Yes           | 0.65             | Stainless steel | <b>252 228-4</b>  |
|  |  | 5/8"        | 17.2 bar<br>(250 psi) | 104 °C<br>(220 °F) | Yes           | 0.45             | Buna-N          | <b>201 643-2*</b> |

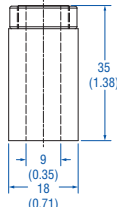
## 1.2 LLE product floats

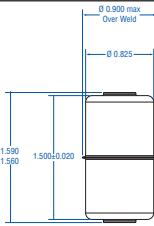
### General notes:

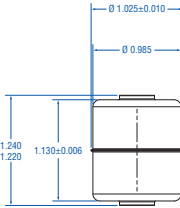
1. Be sure that the float specific gravity is at least 0.05 less than that of the measured liquid as a safety margin at ambient temperature.
2. When the magnet is not shown, the magnet is positioned at the center line of float.
3. Drawings contained in this document are for reference only. Contact the factory for engineering drawings.
4. \* Standard float that can be expedited

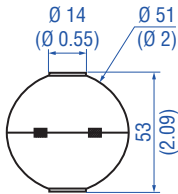
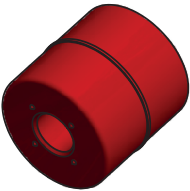
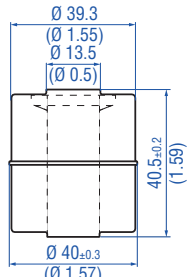





| Photo   | Drawing   | Max Pipe OD | Pressure              | Temperature        | Magnet offset | Specific gravity | Material        | Part no.       |
|---|---|-------------|-----------------------|--------------------|---------------|------------------|-----------------|----------------|
|    |    | 10 mm       | 17.2 bar<br>(250 psi) | 104 °C<br>(220 °F) | No            | 0.75             | Nitrile         | <b>201 120</b> |
|   |   | 7 mm        | 17.2 bar<br>(250 psi) | 104 °C<br>(220 °F) | No            | 0.7              | Nitrile         | <b>201 999</b> |
|  |  | 7 mm        | 10.3 bar<br>(150 psi) | 149 °C<br>(300 °F) | No            | 0.72             | Stainless steel | <b>404 834</b> |
|  |  | 7 mm        | 19 bar<br>(275 psi)   | 149 °C<br>(300 °F) | No            | 0.68             | Stainless steel | <b>404 835</b> |
|  |  | 10 mm       | 51.7 bar<br>(750 psi) | 149 °C<br>(300 °F) | No            | 0.64             | Stainless steel | <b>561 612</b> |
|  |  | 10 mm       | 4 bar<br>(58 psi)     | 80 °C<br>(176 °F)  | No            | 0.53             | Polypropylene   | <b>254 886</b> |

Controlling design dimensions are in millimeters and measurements in ( ) are in inches

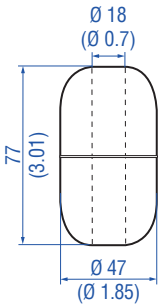
### 1.3 RefineME interface floats

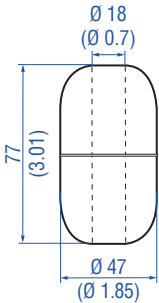
**General notes:**

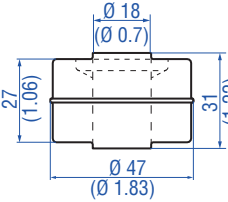
1. RefineME Interface Floats are for a maximum pipe OD of 5/8"
2. For interface measurement: A minimum of 0.05 specific gravity differential is required between the upper and lower liquids.
3. When the magnet is not shown, the magnet is positioned at the center line of float.
4. Drawings contained in this document are for reference only. Contact the factory for engineering drawings.
5. \* Standard float that can be expedited

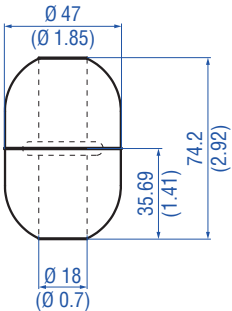
| Photo   | Drawing   | Max Pipe OD | Pressure              | Temperature        | Magnet offset | Specific gravity | Material           | Part no.          |
|---|---|-------------|-----------------------|--------------------|---------------|------------------|--------------------|-------------------|
|    |   | 5/8"        | 29.3 bar<br>(425 psi) | 149 °C<br>(300 °F) | No            | 0.93             | Stainless steel    | <b>251 982-2*</b> |
|   |   |             |                       |                    |               |                  | Nickel Alloy C-276 | <b>251 982-4</b>  |
|  |  | 5/8"        | 29.3 bar<br>(425 psi) | 149 °C<br>(300 °F) | No            | 1.06             | Stainless steel    | <b>251 983-2*</b> |
|   |   |             |                       |                    |               |                  | Nickel Alloy C-276 | <b>251 983-4</b>  |
|  |  | 5/8"        | 4 bar<br>(60 psi)     | 149 °C<br>(300 °F) | Yes           | 0.93             | Stainless steel    | <b>201 606-2*</b> |
|  |  | 5/8"        | 69 bar<br>(1000 psi)  | 149 °C<br>(300 °F) | No            | 0.93             | Stainless steel    | <b>254 894-2</b>  |

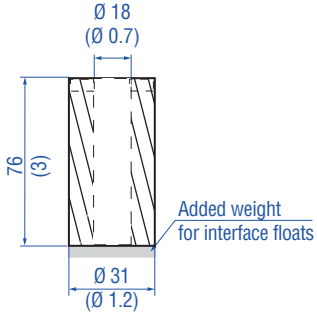
| Photo   | Drawing   | Max Pipe OD | Pressure              | Temperature        | Magnet offset | Specific gravity | Material | Part no.         |
|---|---|-------------|-----------------------|--------------------|---------------|------------------|----------|------------------|
|  |  | 5/8"        | 17.2 bar<br>(250 psi) | 104 °C<br>(220 °F) | Yes           | 0.8 –<br>0.86    | Buna-N   | <b>201 649-2</b> |
|   |   |             |                       |                    |               | 0.91 –<br>0.96   | Buna-N   | <b>201 650-2</b> |

## Accessories for liquid level transmitters

Catalog

### 1.4 SoClean and LLH sanitary floats

#### General notes:

1. Be sure that the float specific gravity is at least 0.05 less than that of the measured liquid as a safety margin at ambient temperature.
2. For interface measurement: A minimum of 0.05 specific gravity differential is required between the upper and lower liquids.
3. Sanitary polish is available for stainless-steel floats up to 200 Grit/Ra 25.
4. Electropolish is available for stainless-steel floats up to 240 Grit/Ra 15.
5. When the magnet is not shown, the magnet is positioned at the center line of float.
6. Drawings contained in this document are for reference only. Contact the factory for engineering drawings.
7. \* Standard float that can be expedited

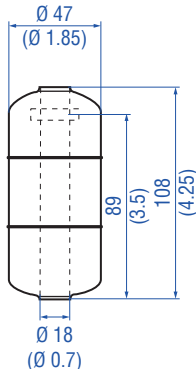
| Photo  | Drawing  | Max Pipe OD | Pressure           | Temperature     | Magnet offset | Specific gravity | Material  | Part no.   |
|--|--|-------------|--------------------|-----------------|---------------|------------------|---|------------|
|  |  | 5/8"        | 10.3 bar (150 psi) | 149 °C (300 °F) | Yes           | 0.66             | Stainless steel<br>200 Grit /<br>Ra 25 µin<br>(0.625 µm)          | 401 513-2* |
|  |  |             |                    |                 |               |                  | Nickel Al-<br>loy C-276<br>200 Grit /<br>Ra 25 unin<br>(0.625 µm) | 402368-2   |
|  |  |             |                    |                 |               |                  | Stainless<br>steel<br>240 Grit /<br>Ra 15 µin<br>(0.375 µm)       | 401 513-4  |
|  |  |             |                    |                 |               |                  | Nickel Al-<br>loy C-276<br>240 Grit /<br>Ra 15uin<br>(0.375 µm)   | 402 368-4  |

#### Note for part no. 401513-X and 402368-X:

- Float meets 3A Sanitary specifications.
- Use this float with all Sanitary transmitter wells as other floats may enter the inactive zone when the tank is emptied.

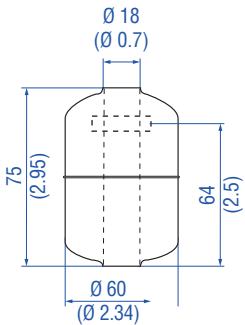
|   |   |      |                    |                 |     |      |  |           |
|---|---|------|--------------------|-----------------|-----|------|--|-----------|
|  |  | 5/8" | 22.4 bar (325 psi) | 149 °C (300 °F) | Yes | 0.63 | Stainless steel<br>200 Grit /<br>Ra 25 µin<br>(0.625 µm) | 200 931-6 |
|   |   |      |                    |                 |     |      | Stainless steel<br>240 Grit /<br>Ra 15 µin<br>(0.375 µm) | 200 931-8 |

#### Note for part no. 200931-X:

- Float meets 3A Sanitary specifications.
- Float will enter inactive zone when the tank is empty.

Controlling design dimensions are in millimeters and measurements in ( ) are in inches

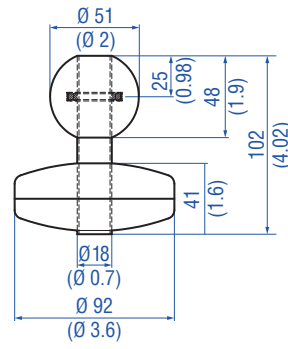
| Photo   | Drawing   | Max Pipe OD | Pressure          | Temperature     | Magnet offset | Specific gravity | Material  | Part no.  |
|---|---|-------------|-------------------|-----------------|---------------|------------------|---|-----------|
|  |  | 5/8"        | 8.6 bar (125 psi) | 149 °C (300 °F) | Yes           | 0.48             | Stainless steel<br>240 Grit /<br>Ra 15 µin (0.375 µm) | 252 228-2 |

**Note for part no. 252 228-2**

Use this float with all Sanitary transmitter wells as other floats may enter the inactive zone when the tank is emptied.

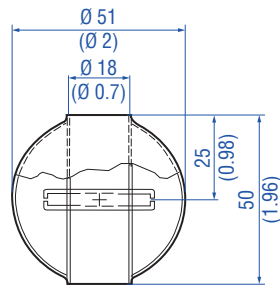
|  |  |      |                    |                 |    |      |   |           |
|--|--|------|--------------------|-----------------|----|------|---|-----------|
|  |  | 5/8" | 22.4 bar (325 psi) | 149 °C (300 °F) | No | 0.74 | Stainless steel<br>200 Grit /<br>Ra 25 µin (0.625 µm) | 251 234-2 |
|--|--|------|--------------------|-----------------|----|------|---|-----------|

**Note for part no. 251 234-2:**

- Float may enter the inactive zone. Consult factory about viability of usage.

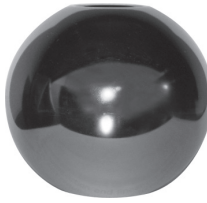
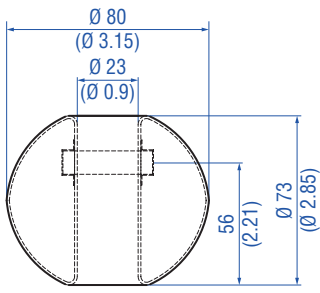
|   |   |      |                  |                 |     |      |   |           |
|---|---|------|------------------|-----------------|-----|------|---|-----------|
|  |  | 5/8" | 64 bar (928 psi) | 149 °C (300 °F) | Yes | 0.86 | Stainless steel<br>240 Grit /<br>Ra 15 µin (0.375 µm) | 560 564-2 |
|---|---|------|------------------|-----------------|-----|------|---|-----------|

**Note for part no. 560 564-2**

- Float meets 3A Sanitary specifications.
- Float may enter the inactive zone. Consult factory about viability of usage.

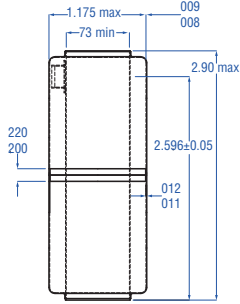
|   |   |      |                  |                 |     |      |   |         |
|---|---|------|------------------|-----------------|-----|------|---|---------|
|  |  | 5/8" | 5.5 bar (80 psi) | 149 °C (300 °F) | Yes | 0.88 | Stainless steel<br>200 Grit /<br>Ra 25 µin (0.625 µm) | 403 374 |
|---|---|------|------------------|-----------------|-----|------|---|---------|

Controlling design dimensions are in millimeters and measurements in ( ) are in inches





## Accessories for liquid level transmitters

Catalog

### 1.5 RefineME FEP floats

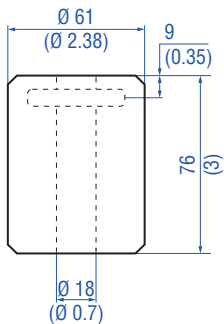
#### General notes:

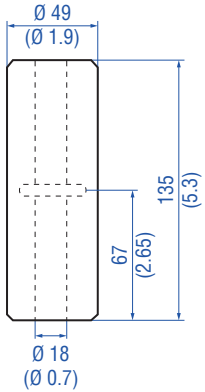

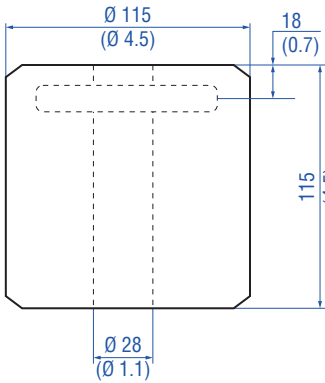

1. Be sure that the float specific gravity is at least 0.05 less than that of the measured liquid as a safety margin at ambient temperature.
2. For interface measurement: A minimum of 0.05 specific gravity differential is required between the upper and lower liquids.
3. When the magnet is not shown, the magnet is positioned at the center line of float.
4. Drawings contained in this document are for reference only. Contact the factory for engineering drawings.
5. Floats 251 939, 251 119, and 251 120 should not be used in hazardous areas. Please consult Installation and operation manual for further details.

| Photo   | Drawing   | Max Pipe OD | Pressure         | Temperature    | Magnet offset | Specific gravity | Material | Part no.  |
|---|---|-------------|------------------|----------------|---------------|------------------|----------|-----------|
|    |   | 5/8"        | 1.7 bar (25 psi) | 38 °C (100 °F) | Yes           | 0.86             | FEP      | 201 109-2 |
|   |   |             |                  |                |               | 0.93             | FEP      | 251 115-2 |
|   |   |             |                  |                |               | 1.06             | FEP      | 251 116-2 |
|  |  | 5/8"        | 1.7 bar (25 psi) | 38 °C (100 °F) | No            | 0.86             | FEP      | 251 939-2 |
|  |  | 5/8"        | 1.7 bar (25 psi) | 38 °C (100 °F) | Yes           | 0.93             | FEP      | 251 119-2 |
|   |   |             |                  |                |               | 1.06             | FEP      | 251 120-2 |

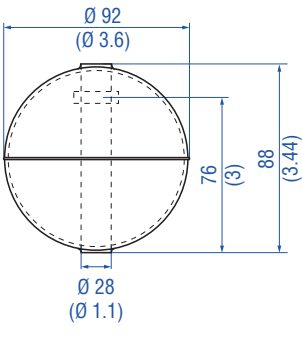

1.6 Long-gauge floats

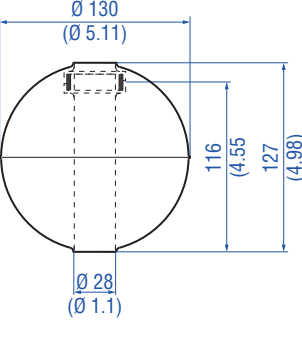
General notes:

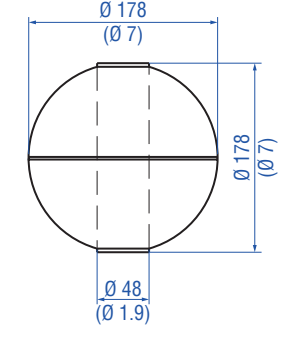
1. Be sure that the float specific gravity is at least 0.05 less than that of the measured liquid as a safety margin at ambient temperature.
2. For interface measurement: A minimum of 0.05 specific gravity differential is required between the upper and lower liquids.
3. When the magnet is not shown, the magnet is positioned at the center line of float.
4. Drawings contained in this document are for reference only. Contact the factory for engineering drawings.
5. \* Standard float that can be expedited

| Photo   | Drawing   | Max Pipe OD | Pressure              | Temperature        | Magnet offset | Specific gravity | Material            | Part no.   |
|---|---|-------------|-----------------------|--------------------|---------------|------------------|---------------------|------------|
|    |   | 7/8"        | 29.3 bar<br>(425 psi) | 149 °C<br>(300 °F) | Yes           | 0.54             | Stainless steel     | 252 961-2* |
|   |   |             |                       |                    |               | 0.65             | Nickel Alloy C-276  | 252 961-4  |
|   |   |             |                       |                    |               | 0.93             | Stainless steel     | 252 962-2  |
|   |   |             |                       |                    |               | 0.93             | Nickel Alloy C-276  | 252 962-4  |
|   |   |             |                       |                    |               | 1.06             | Stainless steel     | 252 963-2  |
|   |   |             |                       |                    |               | 1.06             | Nickel Alloy C-276  | 252 963-4  |
|  |  | 7/8"        | 44.8 bar<br>(650 psi) | 149 °C<br>(300 °F) | Yes           | 0.44             | Stainless steel     | 201 248-2  |
|   |   |             |                       |                    |               | 0.52             | Nickel Alloy C-276  | 201 248-4  |
|   |   |             |                       |                    |               | 0.93             | Stainless steel     | 252 959-2  |
|   |   |             |                       |                    |               | 0.93             | Nickel Alloy C-276  | 252 959-4  |
|   |   |             |                       |                    |               | 1.06             | Stainless steel     | 252 960-2  |
|   |   |             |                       |                    |               | 1.06             | Nickel Alloy C-276  | 252 960-4  |
|  |  | 7/8"        | 17.2 bar<br>(250 psi) | 149 °C<br>(300 °F) | No            | 0.44             | Stainless steel     | 251 426-2  |
|   |   |             |                       |                    |               | 0.47             | Nickel Alloy C-22** | 251 426-4  |
|   |   |             |                       |                    |               | 0.93             | Stainless steel     | 251 427-2  |
|   |   |             |                       |                    |               | 0.93             | Nickel Alloy C-22** | 251 427-4  |
|   |   |             |                       |                    |               | 1.06             | Stainless steel     | 251 428-2  |

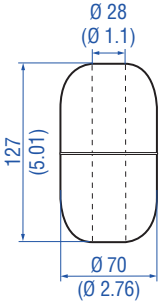
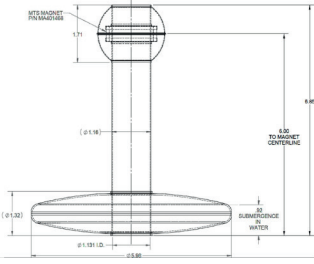
**Accessories for liquid level transmitters**  
Catalog

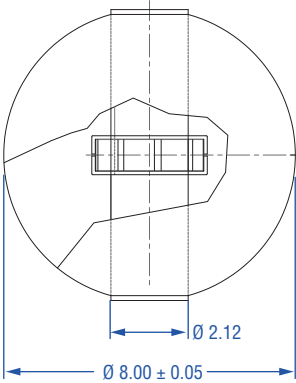
| Photo  | Drawing   | Max Pipe OD | Pressure              | Temperature        | Magnet offset | Specific gravity | Material           | Part no.          |
|--|---|-------------|-----------------------|--------------------|---------------|------------------|--------------------|-------------------|
|   |    | 7/8"        | 22.4 bar<br>(325 psi) | 149 °C<br>(300 °F) | No            | 0.67             | Stainless steel    | <b>201 232-2*</b> |
|  |   |             |                       |                    |               | 0.70             | Nickel Alloy C-276 | <b>201 232-4</b>  |
|  |   |             |                       |                    |               | 0.93             | Stainless steel    | <b>201 233-2</b>  |
|  |    | 7/8"        | 5 bar<br>(75 psi)     | 149 °C<br>(300 °F) | Yes           | 0.97             | Stainless steel    | <b>252999-2</b>   |
|  |  | 7/8"        | 31 bar<br>(450 psi)   | 149 °C<br>(300 °F) | Yes           | 0.4              | Stainless steel    | <b>201715-2</b>   |

\*\* Internal diameter for these floats is 34.8 mm (1.37 in.)

Controlling design dimensions are in millimeters and measurements in ( ) are in inches

## 2. Process meters and enclosures



### 2.1 Analog process meters

| Photo   | Description   | Part no. |
|---|---|----------|
|    | <p><b>LED Display Universal Analog Process Meter</b><br/>(Contact Temposonics for more options including explosion proof housings.)<br/>6 Digit LED display<br/><b>Input:</b> Analog 4...20 mA<br/><b>Output:</b> None<br/>110 VAC Input Power<br/>32 point linearization<br/>Includes 24 Vdc transmitter supply<br/><b>Material:</b> Standard 1/8 in. DIN, high impact plastic, NEMA Type 4X front panel</p>   | 380 071  |
|    | <p><b>LED Display Universal Analog Process Meter (2 Relays)</b><br/>(Contact Temposonics for more options including explosion proof housings.)<br/>6 Digit LED display<br/><b>Input:</b> Analog 4...20 mA<br/><b>Output:</b> 2 relays<br/>110 VAC Input Power<br/>32 point linearization<br/>Includes 24 Vdc transmitter supply<br/><b>Material:</b> Standard 1/8 in. DIN, high impact plastic, NEMA Type 4X front panel</p>                          | 380 072  |
|  | <p><b>LED Display Universal Analog Process Meter (4 Relays)</b><br/>(Contact Temposonics for more options including explosion proof housings.)<br/>6 Digit LED display<br/><b>Input:</b> Analog 4-20 mA<br/><b>Output:</b> 4 relays<br/>110 VAC Input Power<br/>32 point linearization<br/>Includes 24 Vdc transmitter supply<br/><b>Material:</b> Standard 1/8 in. DIN, high impact plastic, NEMA Type 4X front panel</p>                            | 380 073  |
|  | <p><b>LED Display Universal Analog Process Meter (2 Relays, 4...20 mA)</b><br/>(Contact Temposonics for more options including explosion proof housings.)<br/>6 Digit LED display<br/><b>Input:</b> Analog 4...20 mA<br/><b>Output:</b> 4...20 mA and 2 relays<br/>110 VAC Input Power<br/>32 point linearization<br/>Includes 24 Vdc transmitter supply<br/><b>Material:</b> Standard 1/8 in. DIN, high impact plastic, NEMA Type 4X front panel</p> | 380 095  |
|  | <p><b>Loop Powered Analog Meter</b><br/>Loop Powered on 4...20 mA output<br/>Displays loop current, engineering units, and/or value<br/>Selectable on screen engineering units<br/>IP 67 / NEMA Type 4X<br/>Intrinsically Safe, backlight</p>   | 380 088  |

## Accessories for liquid level transmitters

Catalog

### 2.2 Modbus process meters

| Photo   | Description  | Part no. |
|---|--|----------|
|  | <p><b>Multivariable Modbus Process Meter</b><br/>                     Display levels in feet, inches, and 16ths of an inch<br/> <b>Input:</b> RS485 Modbus RTU<br/> <b>Output:</b> 2 Form A relays and 4...20 mA<br/>                     110 VAC Input Power<br/>                     16 point linearization<br/>                     Includes 24 Vdc transmitter supply<br/> <b>Material:</b> Standard 1/8 in. DIN, high impact plastic, NEMA Type 4X front panel</p>  | 380 086  |
|  | <p><b>Single Variable Modbus Process Meter</b><br/>                     (Contact Temposonics for more options including explosion proof housings.)<br/>                     6 Digit Display in Decimal Format<br/>                     Display 1 process variable without interrupting Master/Slave communication<br/> <b>Input:</b> RS485 Modbus RTU<br/> <b>Output:</b> 2 Form A relays and 4...20 mA<br/>                     110 VAC Input Power<br/>                     16 point linearization<br/>                     Includes 24 Vdc transmitter supply<br/> <b>Material:</b> Standard 1/8 in. DIN, high impact plastic, NEMA Type 4X front panel</p> | 380 094  |

### 2.3 Process meter enclosures

| Photo   | Description   | Part no. |
|---|---|----------|
|  | <p><b>NEMA Enclosures - Single NEMA 4X</b><br/>                     (NEMA Enclosures are available for most process meters, please contact factory for more information.)</p> | 401 150  |
|   | <p><b>NEMA Enclosures - Dual NEMA 4X</b><br/>                     (NEMA Enclosures are available for most process meters, please contact factory for more information.)</p>   | 401 151  |

### 2.4 Modbus Terminals

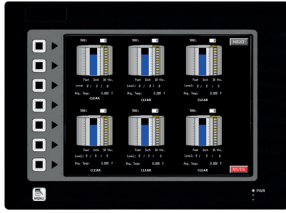

| Photo   | Description   | Part no.                        |
|---|---|---------------------------------|
|  | <p><b>Touchscreen Modbus Terminal</b><br/>                     Displays up to 16 tanks (2 levels, temp, volume)<br/>                     Displays levels in ft., in, and 16ths in.<br/> <b>Input:</b> up to 16 Modbus transmitters<br/> <b>Output:</b> Modbus<br/>                     Pictorial display of tanks<br/>                     Touchscreen<br/>                     Mounted in NEMA 4 box<br/>                     Class 1, Div. 2, Groups ABCD<br/>                     ATEX/IECEx<br/>                     Ex ic nA IIC T4 Gc<br/>                     Includes Power Supply<br/>                     Calibrate from Screen</p> | 280897-X (7")<br>280898-X (10") |

### 3. Programming and hardware





#### 3.1 Setup software

| Photo   | Description         | Part no. |
|---|---------------------|----------|
|  | LP-Dashboard on USB | 551 719  |

#### 3.2 Hardware

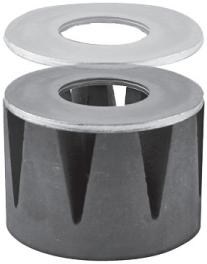
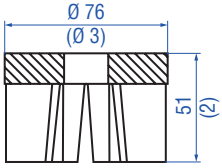
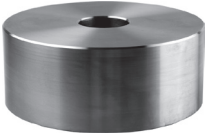
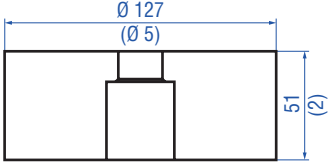
| Photo   | Description                     | Part no. |
|---|---------------------------------|----------|
|   | HART® to USB adapter            | 380 068  |
|  | RS-485 to USB adapter converter | 380 114  |

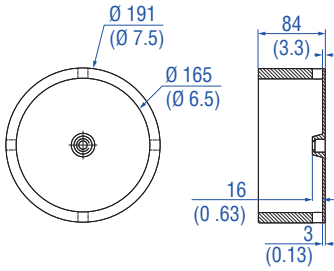
## 4. Magnet and weight assemblies

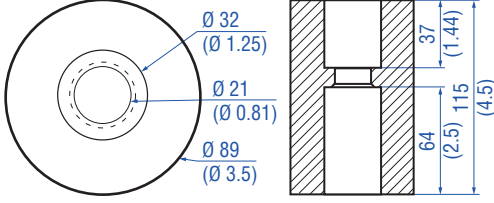
| Photo   | Drawing   | Description   | Part no.       |
|---|---|---|----------------|
|    |    | <b>150 lb. Pull Magnet</b><br>For Tank SLAYER® level transmitter.<br>(Washer must be removed before installation) | <b>560 604</b> |
|    |    | <b>Standard 11 lb. Weight</b><br>For LP-Series transmitters   | <b>401 059</b> |
|  |  | <b>Low Lutoff 11 lb. Weight Assembly</b>  | <b>402 364</b> |
|  |  | <b>Narrow 11 lb. Weight</b><br>Use with LP-Series transmitters  | <b>402 647</b> |

**UNITED STATES**  
**Temposonics, LLC**  
Americas & APAC Region  
3001 Sheldon Drive  
Cary, N.C. 27513  
Phone: +1 919 677-0100  
E-mail: info.us@temposonics.com

**GERMANY**  
**Temposonics**  
**GmbH & Co. KG**  
EMEA Region & India  
Auf dem Schüffel 9  
58513 Lüdenscheid  
Phone: +49 2351 9587-0  
E-mail: info.de@temposonics.com

**ITALY**  
Branch Office  
Phone: +39 030 988 3819  
E-mail: info.it@temposonics.com

**FRANCE**  
Branch Office  
Phone: +33 6 14 060 728  
E-mail: info.fr@temposonics.com

**UK**  
Branch Office  
Phone: +44 79 21 83 05 86  
E-mail: info.uk@temposonics.com

**SCANDINAVIA**  
Branch Office  
Phone: +46 70 29 91 281  
E-mail: info.sca@temposonics.com

**CHINA**  
Branch Office  
Phone: +86 21 3405 7850  
E-mail: info.cn@temposonics.com

**JAPAN**  
Branch Office  
Phone: +81 3 6416 1063  
E-mail: info.jp@temposonics.com

**Document Part Number:**  
551103 Revision J (EN) 01/2026



**temposonics.com**