

## Data Sheet

# R-Series V RH5 Analog

## Magnetostrictive Linear Position Sensors

- Output of position and speed/velocity
- Dual magnet position measurement
- Field adjustments and diagnostics using the TempoLink® smart assistant

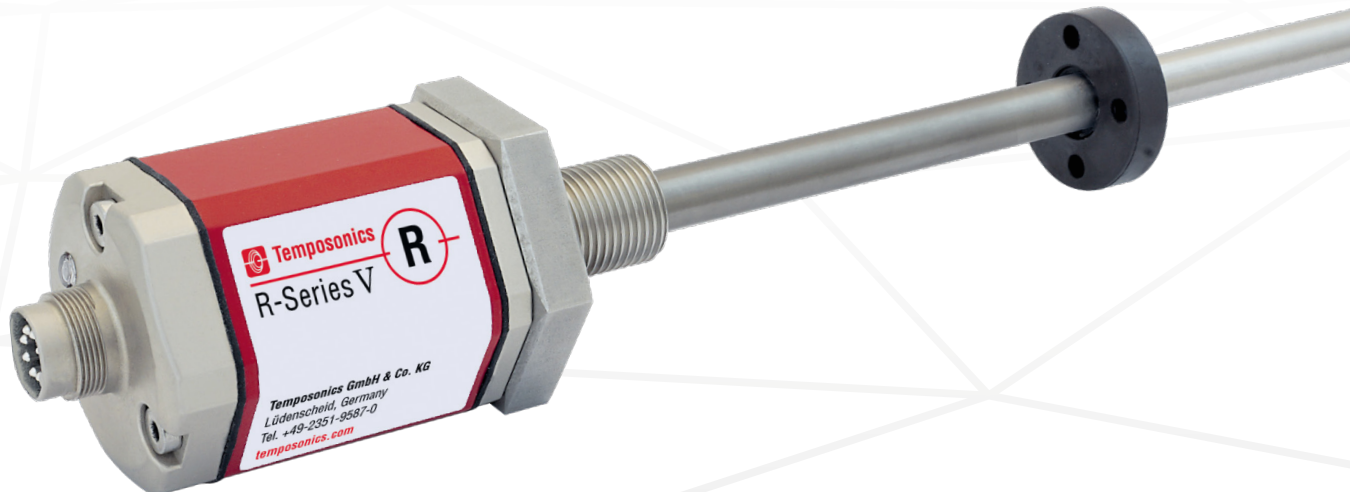

**V**  
THE NEW GENERATION

## MEASURING TECHNOLOGY

The absolute, linear position sensors provided by Temposonics rely on the company's proprietary magnetostrictive technology, which can determine position with a high level of precision and robustness. Each Temposonics® position sensor consists of a ferromagnetic waveguide, a position magnet, a strain pulse converter and a supporting electronics. The magnet, connected to the object in motion in the application, generates a magnetic field at its location on the waveguide. A short current pulse is applied to the waveguide. This creates a momentary radial magnetic field and torsional strain on the waveguide. The momentary interaction of the magnetic fields releases a torsional strain pulse that propagates the length of the waveguide. When the ultrasonic wave reaches the beginning of the waveguide it is converted into an electrical signal. Since the speed of the ultrasonic wave in the waveguide is precisely known, the time required to receive the return signal can be converted into a linear position measurement with both high accuracy and repeatability.

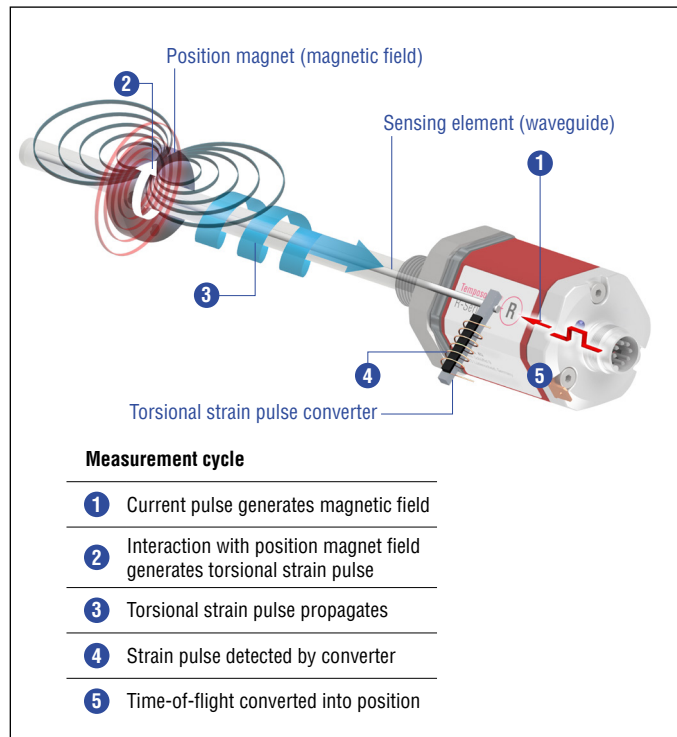
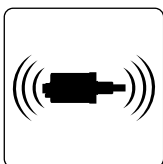

Fig. 1: Time-of-flight based magnetostrictive position sensing principle

## R-SERIES V RH5 Analog

The Temposonics® R-Series V brings very powerful sensor performance to meet the many demands of your application. The main advantages of the rod version RH5 with Analog output (current/voltage) are:



**High shock and vibration resistance**  
The R-Series V is the long term solution for harsh environments that have high levels of shock and vibration.

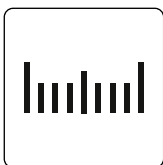

**Internal resolution 0.1  $\mu\text{m}$**   
The sensor works with an internal resolution of 0.1  $\mu\text{m}$  to detect and report smallest position changes.

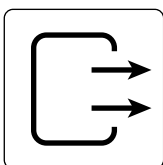

**Dual output channel**  
The sensor is available with single output channel or with dual output channels.

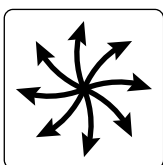

**Multiple output options**  
The following values can be output via the second output:

- Speed/velocity of the first magnet
- Reversed position of the first magnet
- Position of the second magnet
- Temperature in the sensor electronics housing

In addition the R-Series V Analog scores with the following features:

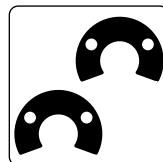

**2 positions simultaneously**  
The R-Series V Analog can detect and report the position of up to 2 magnets simultaneously.

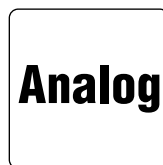

**R-Series V Analog**  
With the R-Series V Analog you can configure the Analog output (current/voltage) for your application and also adjust it on site with the smart assistant.

**All settings under control with the smart assistant for the R-Series V**  
The TempoLink® smart assistant supports you in setup and diagnostics of the R-Series V. For more information of the assistant please see the data sheet:

- TempoLink® smart assistant  
(Document part number: [552070](#))



## TECHNICAL DATA

Output							
Analog	Voltage: 0...10/10...0/-10...+10/+10...-10 VDC (min. controller load > 5 kΩ) Current: 4(0)...20/20...4(0) mA (min./max. load 0/500 Ω)						
Measured output variables	Position for one or two position magnets Position + speed (without direction) or velocity (with direction) for one position magnet Position for one position magnet + temperature inside the sensor electronics housing						
Measurement parameters							
Position measurement							
Null/Span adjustment	100 % of electrical stroke						
Resolution	16 bit (internal resolution 0.1 μm)						
Update time	Stroke length	≤ 200 mm	≤ 350 mm	≤ 1200 mm	≤ 2400 mm	≤ 4800 mm	≤ 7620 mm
	Update time	0.25 ms	0.333 ms	0.5 ms	1.0 ms	2.0 ms	5.0 ms
Linearity deviation <sup>1</sup>	< ±0.01 % F.S. (minimum ±50 μm)						
Repeatability	< ±0.001 % F.S. (minimum ±1 μm)						
Hysteresis	< 4 μm typical						
Temperature coefficient	< 30 ppm/K typical						
Speed/velocity measurement							
Range	0.01...10 m/s or 1...400 in./s						
Deviation	≤ 0.05 %						
Resolution	16 bit (minimum 0.01 mm/s)						
Operating conditions							
Operating temperature	-40...+85 °C (-40...+185 °F)						
Humidity	90 % relative humidity, no condensation						
Ingress protection	IP67 (connectors correctly fitted)/IP68 (3 m/3 d) for cable outlet						
Shock test	150 g/11 ms, IEC standard 60068-2-27						
Vibration test	30 g/10...2000 Hz, IEC standard 60068-2-6 (excluding resonant frequencies)/ RH5-J: 15 g / 10...2000 Hz, IEC standard 60068-2-6 (excluding resonant frequencies)						
EMC test	Electromagnetic emission according to EN 61000-6-3						
	Electromagnetic immunity according to EN 61000-6-2 The RH5 sensors fulfill the requirements of the EMC directives 2014/30/EU, UKSI 2016 No. 1091 and TR CU 020/2011						
Operating pressure	350 bar (5,070 psi)/700 bar (10,150 psi) peak (at 10 × 1 min) for sensor rod/RH5-J: 800 bar (11,600 psi)						
Magnet movement velocity	Any						
Design/Material							
Sensor electronics housing	Aluminum (painted), zinc die cast						
Sensor flange	Stainless steel 1.4305 (AISI 303)						
Sensor rod	Stainless steel 1.4306 (AISI 304L)/RH5-J: Stainless steel 1.4301 (AISI 304)						
RoHS compliance	The used materials are compliant with the requirements of EU Directive 2011/65/EU and EU Regulation 2015/863 as well as UKSI 2022 No. 622						
Stroke length	25...7620 mm (1...300 in.)/RH5-J: 25...5900 mm (1...232 in.)						
Mechanical mounting							
Mounting position	Any						
Mounting instruction	Please consult the technical drawings on <a href="#">page 5</a> , <a href="#">page 6</a> and the operation manual (document part number: <a href="#">552063</a> )						

Technical data "Electrical connection" on [page 4](#)

1/ With position magnet # 251 416-2

## Temposonics® R-Series V RH5 Analog

### Data Sheet

Electrical connection	
Connection type	1 × M16 male connector (6 pin), 1 × M12 male connector (5 pin) or cable outlet
Operating voltage	12...30 VDC ±20 % (9.6...36 VDC)
Power consumption	< 3.25 W
Dielectric strength	500 VDC (DC ground to machine ground)
Polarity protection	Up to -36 VDC
Overvoltage protection	Up to 36 VDC

TECHNICAL DRAWING

**RH5-M/-S-A/-V – RH5 with threaded flange M18×1.5-6g or ¾"-16 UNF-3A, example: Connection type D60 (connector outlet)**

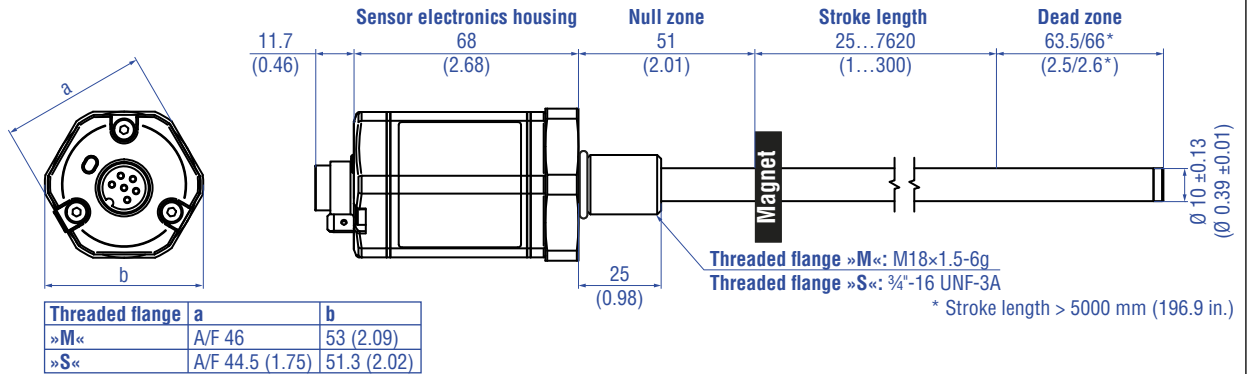

**RH5-T-A/-V – RH5 with threaded flange ¾"-16 UNF-3A with raised-face, example: Connection type EXX/GXX/LXX/UXX (angled cable outlet)**

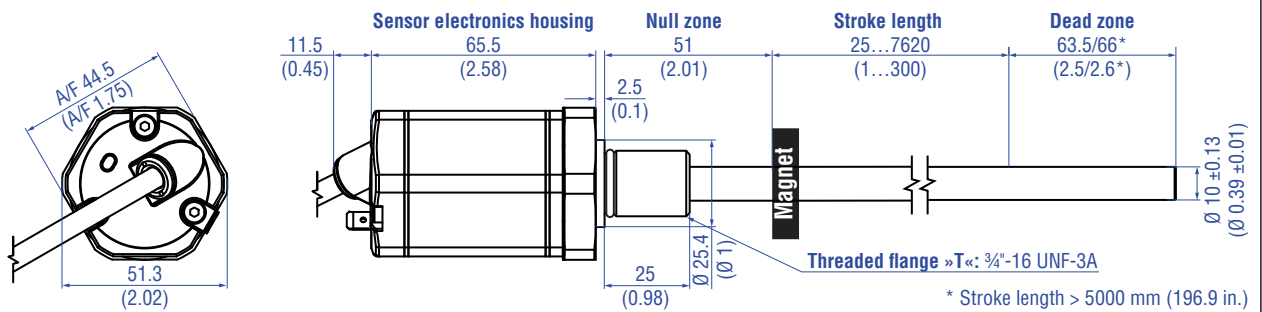

**RH5-T-A/-V – RH5 with threaded flange ¾"-16 UNF-3A with raised-face, example: Connection type HXX/RXX/TXX (straight cable outlet)**

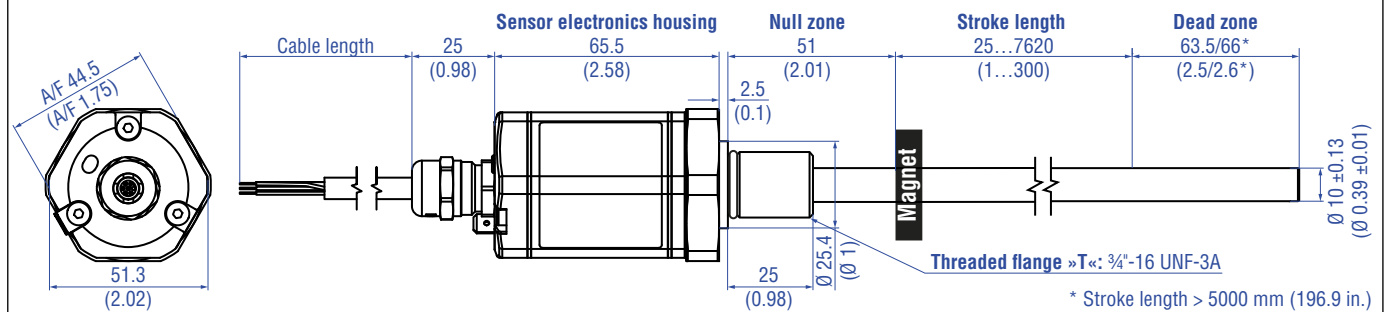

**Mechanical option »B«: Bushing on rod end for threaded flange M18×1.5-6g or ¾"-16 UNF-3A**

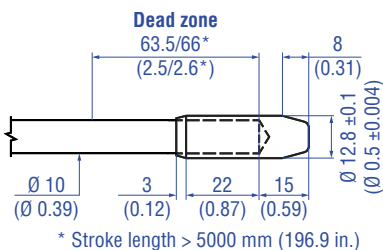

**Mechanical option »M«: Thread M4 at rod end for threaded flange M18×1.5-6g or ¾"-16 UNF-3A**

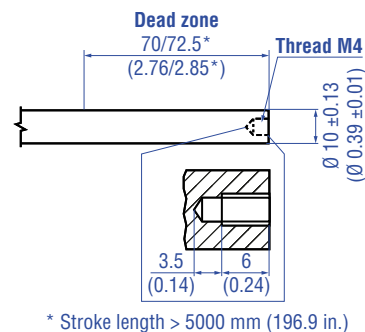

Controlling design dimensions are in millimeters and measurements in ( ) are in inches

Fig. 2: Temposonics® RH5 with ring magnet, part 1

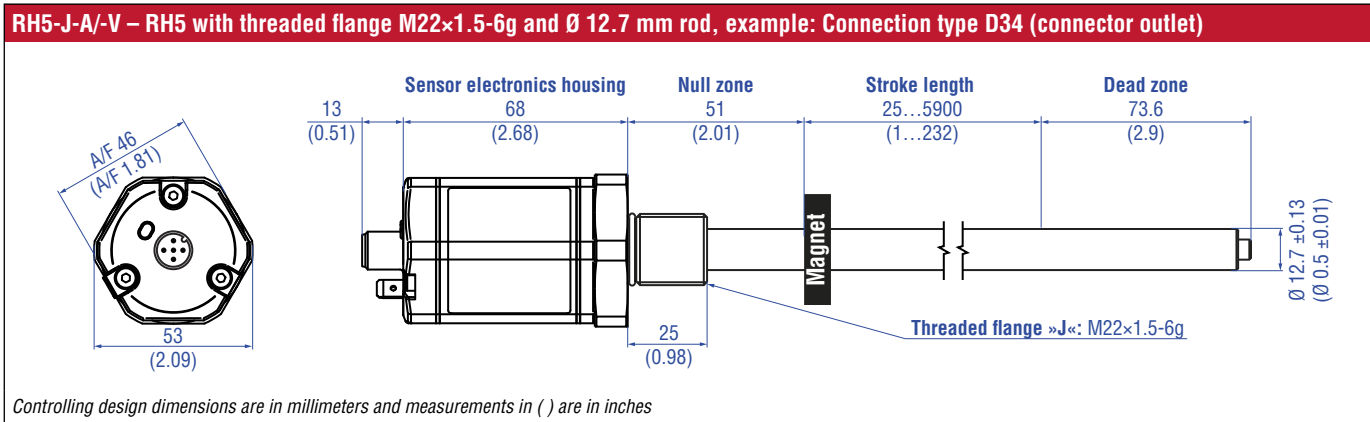

Fig. 3: Temposonics® RH5 with ring magnet, part 2

## CONNECTOR WIRING

D34			
Signal + power supply			
M12 male connector	Output	Pin	Function
 <p>View on sensor</p>	1	1	+12...30 VDC (±20 %)
		2	Position (magnet 1)
		3	DC Ground (0 V)
	2*	4	Position (magnet 2) or reverse position (magnet 1) or speed or velocity (magnet 1) or temperature inside the sensor electronics housing
		5	Signal Ground
* order dependent			

Fig. 4: Connector wiring D34

D60			
Signal + power supply			
M16 male connector	Output	Pin	Function
 <p>View on sensor</p>	1	1	Position (magnet 1)
		2	Signal Ground
	2*	3	Position (magnet 2) or reverse position (magnet 1) or speed or velocity (magnet 1) or temperature inside the sensor electronics housing
		4	Signal Ground
		5	+12...30 VDC (±20 %)
		6	DC Ground (0 V)
* order dependent			

Fig. 5: Connector wiring D60

HXX or LXX / RXX or EXX / TXX or GXX / UXX				
Signal + power supply				
Cable	Output	Color	Function	
	1	GY	Position (magnet 1)	
		PK	Signal Ground	
	2*	YE	Position (magnet 2) or reverse position (magnet 1) or speed or velocity (magnet 1) or temperature inside the sensor electronics housing	
		GN	Signal Ground	
		BN	+12...30 VDC (±20 %)	
		WH	DC Ground (0 V)	
	* order dependent			
	For cable type TXX, the extra red & blue wires are not used.			

Fig. 6: Connector wiring cable outlet

**NOTICE**

For sensors with current output (order code section **h** Output **A** Current), the output 1 (position (magnet 1)) must be connected in any case.

Straight cable outlet			Cable type	Angled cable outlet			
<b>H</b>	<b>X</b>	<b>X</b>	Part no. 530 052 PUR →	<b>L</b>	<b>X</b>	<b>X</b>	Part no. 530 052
<b>R</b>	<b>X</b>	<b>X</b>	Part no. 530 032 PVC →	<b>E</b>	<b>X</b>	<b>X</b>	Part no. 530 032
<b>T</b>	<b>X</b>	<b>X</b>	Part no. 530 112 FEP →	<b>G</b>	<b>X</b>	<b>X</b>	Part no. 530 157

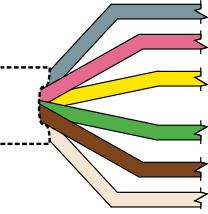
Fig. 7: Cable types assignment

**FREQUENTLY ORDERED ACCESSORIES** – Additional options available in our [Accessories Catalog](#) 551444



Position magnets					
<p><b>U-magnet OD33</b> Part no. 251 416-2</p>	<p><b>Ring magnet OD33</b> Part no. 201 542-2</p>	<p><b>Ring magnet OD25.4</b> Part no. 400 533</p>	<p><b>Ring magnet</b> Part no. 402 316</p>		
<p>Material: PA ferrite GF20 Weight: Approx. 11 g Surface pressure: Max. 40 N/mm<sup>2</sup> Fastening torque for M4 screws: 1 Nm Operating temperature: -40...+105 °C (-40...+221 °F)</p>	<p>Material: PA ferrite GF20 Weight: Approx. 14 g Surface pressure: Max. 40 N/mm<sup>2</sup> Fastening torque for M4 screws: 1 Nm Operating temperature: -40...+105 °C (-40...+221 °F)</p>	<p>Material: PA ferrite Weight: Approx. 10 g Surface pressure: Max. 40 N/mm<sup>2</sup> Operating temperature: -40...+105 °C (-40...+221 °F)</p>	<p>Material: PA ferrite coated Weight: Approx. 13 g Surface pressure: Max. 20 N/mm<sup>2</sup> Operating temperature: -40...+100 °C (-40...+212 °F)</p>		
Position magnet		Magnet spacer		O-rings	
<p><b>Block magnet L</b> Part no. 403 448</p>	<p><b>Magnet spacer</b> Part no. 400 633</p>	<p><b>O-ring for threaded flange</b> M18×1.5-6g Part no. 401 133</p>	<p><b>O-ring for threaded flange</b> ¾"-16 UNF-3A Part no. 560 315</p>	<p><b>O-ring for threaded flange</b> M22×1.5-6g Part no. 561 337</p>	<p><b>Hex jam nut M18×1.5-6g</b> Part no. 500 018</p>
<p>Material: Plastic carrier with hard ferrite magnet Weight: Approx. 20 g Fastening torque for M4 screws: 1 Nm Operating temperature: -40...+75 °C (-40...+167 °F)</p> <p>This magnet may influence the sensor performance specifications for some applications.</p>	<p>Material: Aluminum Weight: Approx. 5 g Surface pressure: Max. 20 N/mm<sup>2</sup> Fastening torque for M4 screws: 1 Nm</p>	<p>Material: Fluoroelastomer Durometer: 75 ± 5 Shore A Operating temperature: -40...+204 °C (-40...+400 °F)</p>	<p>Material: Fluoroelastomer Durometer: 75 ± 5 Shore A Operating temperature: -40...+204 °C (-40...+400 °F)</p>	<p>Material: FPM Durometer: 75 Shore A Operating temperature: -20...+200 °C (-6...+392 °F)</p>	<p>Material: Steel, zinc plated</p>
O-ring		Mounting accessories			
<p><b>O-ring for threaded flange</b> M22×1.5-6g Part no. 561 337</p>	<p><b>Hex jam nut M18×1.5-6g</b> Part no. 500 018</p>	<p><b>Hex jam nut ¾"-16 UNF-3A</b> Part no. 500 015</p>	<p><b>Hex jam nut ¾"-16 UNF-3A</b> Part no. 500 015</p>	<p><b>Fixing clip</b> Part no. 561 481</p>	<p><b>Hex jam nut ¾"-16 UNF-3A</b> Part no. 500 015</p>
<p>Material: FPM Durometer: 75 Shore A Operating temperature: -20...+200 °C (-6...+392 °F)</p>	<p>Material: Steel, zinc plated</p>	<p>Material: Steel, zinc plated</p>	<p>Material: Steel, zinc plated</p>	<p>Application: Used to secure sensor rods (Ø 10 mm (Ø 0.39 in.)) when using an U-magnet or block magnet Material: Brass, non-magnetic</p>	<p>Material: Steel, zinc plated</p>

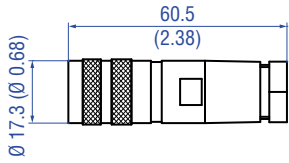
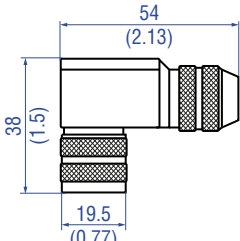
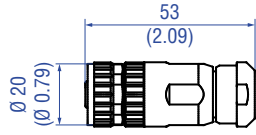
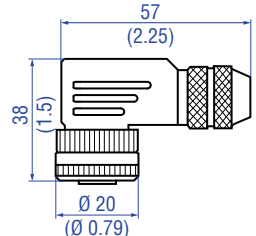

**Cable connectors\***

			
<p><b>M16 female connector (6 pin), straight</b> <b>Part no. 370 423</b></p> <p>Material: Zinc nickel plated Termination: Solder Cable Ø: 6...8 mm (0.24...0.31 in.) Operating temperature: -40...+100 °C (-40...+212 °F) Ingress protection: IP65/IP67 (correctly fitted) Fastening torque: 0.6 Nm</p>	<p><b>M16 female connector (6 pin), angled</b> <b>Part no. 370 460</b></p> <p>Material: Zinc nickel plated Termination: Solder Cable Ø: 6...8 mm (0.24...0.31 in.) Wire: 0.75 mm<sup>2</sup> (20 AWG) Operating temperature: -40...+95 °C (-40...+203 °F) Ingress protection: IP67 (correctly fitted) Fastening torque: 0.6 Nm</p>	<p><b>M12 A-coded female connector (4 pin/5 pin), straight</b> <b>Part no. 370 677</b></p> <p>Material: GD-Zn, Ni Termination: Screw Contact insert: CuZn Cable Ø: 4...8 mm (0.16...0.31 in.) Wire: 1.5 mm<sup>2</sup> Operating temperature: -30...+85 °C (-22...+185 °F) Ingress protection: IP67 (correctly fitted) Fastening torque: 0.6 Nm</p>	<p><b>M12 A-coded female connector (5 pin), angled</b> <b>Part no. 370 678</b></p> <p>Material: GD-Zn, Ni Termination: Screw; max. 0.75 mm<sup>2</sup> Contact insert: CuZn Cable Ø: 5...8 mm (0.2...0.31 in.) Wire: 0.75 mm<sup>2</sup> (18 AWG) Operating temperature: -25...+85 °C (-13...+185 °F) Ingress protection: IP67 (correctly fitted) Fastening torque: 0.4 Nm</p>

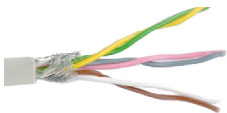
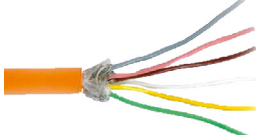
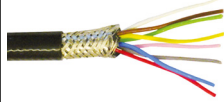
**Cables**

			
<p><b>PVC cable</b> <b>Part no. 530 032</b></p> <p>Material: PVC jacket; gray Features: Twisted pair, shielded, flexible Cable Ø: 6 mm (0.23 in.) Cross section: 3 × 2 × 0.14 mm<sup>2</sup> Bending radius: 10 × D (fixed installation) Operating temperature: -40...+105 °C (-40...+221 °F)</p>	<p><b>PUR cable</b> <b>Part no. 530 052</b></p> <p>Material: PUR jacket; orange Features: Twisted pair, shielded, highly flexible, halogen free, suitable for drag chains, mostly oil &amp; flame resistant Cable Ø: 6.4 mm (0.25 in.) Cross section: 3 × 2 × 0.25 mm<sup>2</sup> Bending radius: 5 × D (fixed installation) Operating temperature: -30...+80 °C (-22...+176 °F)</p>	<p><b>FEP cable</b> <b>Part no. 530 112</b></p> <p>Material: FEP jacket; black Features: Twisted pair, shielded, flexible, high thermal resistance, mostly oil &amp; acid resistant Cable Ø: 7.6 mm (0.3 in.) Cross section: 4 × 2 × 0.25 mm<sup>2</sup> Bending radius: 8 – 10 × D (fixed installation) Operating temperature: -100...+180 °C (-148...+356 °F)</p>	<p><b>FEP cable</b> <b>Part no. 530 157</b></p> <p>Material: FEP jacket; black Features: Twisted pair, shielded Cable Ø: 6.7 mm (0.26 in.) Cross section: 3 × 2 × 0.14 mm<sup>2</sup> Operating temperature: -40...+180 °C (-40...+356 °F)</p>

\*/ Follow the manufacturer's mounting instructions  
Color of connectors and cable jacket may change. Color codes for the individual wires and technical properties remain unchanged.  
Controlling design dimensions are in millimeters and measurements in ( ) are in inches

**Cable** **Cable sets**

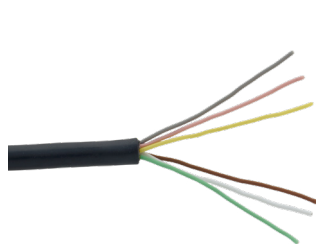

**Silicone cable**  
Part no. 530 176

Material: Silicone jacket; black  
Features: Twisted pair, shielded  
Cable Ø: 6.3 mm (0.25 in.)  
Cross section: 3 × 2 × 0.14 mm<sup>2</sup>  
Bending radius: 7 × D  
(fixed installation)  
Operating temperature: -50...+150 °C  
(-58...+302 °F)



**Cable with M12 A-coded female connector (5 pin), straight – pigtail**  
Part no. 370 673

Material: PUR jacket; black  
Features: Shielded  
Cable length: 5 m (16.4 ft)  
Ingress protection: IP67 (correctly fitted)  
Operating temperature:  
-25...+80 °C (-13...+176 °F)



**Cable with M12 A-coded female connector (5 pin), angled – pigtail**  
Part no. 370 675

Material: PUR jacket; black  
Features: Shielded  
Cable length: 5 m (16.4 ft)  
Ingress protection: IP67 (correctly fitted)  
Operating temperature:  
-25...+80 °C (-13...+176 °F)

**Programming tools**



**Hand programmer for analog output**  
Part no. 253 124

Easy teach-in-setups of stroke length and direction on desired zero / span positions. For sensors with 1 magnet.



**Cabinet programmer for analog output**  
Part no. 253 408

Features snap-in mounting on standard DIN rail (35 mm). This programmer can be permanently mounted in a control cabinet and includes a program/run switch. For sensors with 1 magnet.



**TempoLink® kit for Temposonics® R-Series V**  
Part no. TL-1-0-AD60 (for D60)  
Part no. TL-1-0-AS00 (for cable outlet)  
Part no. TL-1-0-AD34 (for D34)

- Connect wirelessly via Wi-Fi enabled device or via USB with the diagnostic tool
- Simple connectivity to the sensor via 24 VDC power line (permissible cable length: 30 m)
- User friendly interface for mobile devices and desktop computers
- See data sheet “TempoLink® smart assistant” (document part no.: [552070](#)) for further information

Controlling design dimensions are in millimeters and measurements in ( ) are in inches  
Color of connectors and cable jacket may change. Color codes for the individual wires and technical properties remain unchanged.

**Extension cables M12**



**PVC cable with M12 female connector (6 pin), straight – pigtail**

PVC cable (part no. 530 032) with M12 female connector, straight (part no. 370 677)

Order code:  
**K2-A-370677-xxxxyy-530032-0**  
(where xxxx = cable length and yy = unit in centimeters “CM” or feet “FT”)



**PUR cable with M12 female connector (6 pin), straight – pigtail**

PUR cable (part no. 530 052) with M12 female connector, straight (part no. 370 677)

Order code:  
**K2-A-370677-xxxxyy-530052-0**  
(where xxxx = cable length and yy = unit in centimeters “CM” or feet “FT”)



**FEP cable with M12 female connector (6 pin), straight – pigtail**

FEP cable (part no. 530 112) with M12 female connector, straight (part no. 370 677)

Order code:  
**K2-A-370677-xxxxyy-530112-0**  
(where xxxx = cable length and yy = unit in centimeters “CM” or feet “FT”)

**Extension cables M16**

**Notice for extension cables M12/M16**



**PVC cable with M16 female connector (6 pin), straight – pigtail**

PVC cable (part no. 530 032) with M16 female connector, straight (part no. 370 423)

Order code:  
**K2-A-370423-xxxxyy-530032-0**  
(where xxxx = cable length and yy = unit in centimeters “CM” or feet “FT”)



**PUR cable with M16 female connector (6 pin), straight – pigtail**

PUR cable (part no. 530 052) with M16 female connector, straight (part no. 370 423)

Order code:  
**K2-A-370423-xxxxyy-530052-0**  
(where xxxx = cable length and yy = unit in centimeters “CM” or feet “FT”)



**FEP cable with M16 female connector (6 pin), straight – pigtail**

FEP cable (part no. 530 112) with M16 female connector, straight (part no. 370 423)

Order code:  
**K2-A-370423-xxxxyy-530112-0**  
(where xxxx = cable length and yy = unit in centimeters “CM” or feet “FT”)

Standard cable lengths		
Meters	Feet	Code
1.5	5	0150
2	6.6	0200
4.6	15	0460
5	16.4	0500
7.6	25	0760
10	32.8	1000
15.2	50	1520

For additional extension cables reference the accessory catalog for industrial sensors (document part no.: [551444](#)).

Color of connectors and cable jacket may change. Color codes for the individual wires and technical properties remain unchanged.

## ORDER CODE

1	2	3	4	5	6	7	8	9	10	11	12	13	14	15	16	17	18	19	20	21	22	23	
R	H	5													1								
a			b	c	d					e		f			g	h	i	j	k	l			

optional

a	Sensor model
R H 5	Rod

b	Design
B	Base unit (only for replacement)
J	Threaded flange M22×1.5-6g (rod Ø 12.7 mm), stroke length: 25...5900 mm (1...232 in.)
M	Threaded flange M18×1.5-6g (standard)
S	Threaded flange ¾"-16 UNF-3A (standard)
T	Threaded flange ¾"-16 UNF-3A (with raised-face)

c	Mechanical options
A	Standard
B	Bushing on rod end (only for design »M«, »S« & »T«)
M	Thread M4 at rod end (only for design »M«, »S« & »T«)
V	Fluorelastomer seals for the sensor electronics housing

d	Stroke length
X X X X M	0025...7620 mm
Standard stroke length (mm)	Ordering steps
25... 500 mm	5 mm
500... 750 mm	10 mm
750...1000 mm	25 mm
1000...2500 mm	50 mm
2500...5000 mm	100 mm
5000...7620 mm	250 mm
X X X X U	001.0...300.0 in.
Standard stroke length (in.)	Ordering steps
1... 20 in.	0.2 in.
20... 30 in.	0.4 in.
30... 40 in.	1.0 in.
40...100 in.	2.0 in.
100...200 in.	4.0 in.
200...300 in.	10.0 in.
Non-standard stroke lengths are available; must be encoded in 5 mm/0.1 in. increments.	

e	Number of magnets
0 X	01...02 Position(s) (1...2 magnet(s))

f	Connection type
Connector	
D 3 4	M12 male connector (5 pin)
D 6 0	M16 male connector (6 pin)
Angled cable outlet	
E X X	XX m/ft. PVC cable (part no. 530 032) E01...E30 (1...30 m/3...99 ft.) See "Frequently ordered accessories" for cable specifications
G X X	XX m/ft. FEP cable (part no. 530 157) G01...G30 (1...30 m/3...99 ft.) See "Frequently ordered accessories" for cable specifications
L X X	XX m/ft. PUR cable (part no. 530 052) L01...L30 (1...30 m/3...99 ft.) (Note the temperature range of the cable!) See "Frequently ordered accessories" for cable specifications
U X X	XX m/ft. Silicone cable (part no. 530 176) U01...U30 (1...30 m/3...99 ft.) See "Frequently ordered accessories" for cable specifications
Straight cable outlet	
H X X	XX m/ft. PUR cable (part no. 530 052) H01...H30 (1...30 m/3...99 ft.) (Note the temperature range of the cable!) See "Frequently ordered accessories" for cable specifications
R X X	XX m/ft. PVC cable (part no. 530 032) R01...R30 (1...30 m/3...99 ft.) See "Frequently ordered accessories" for cable specifications
T X X	XX m/ft. FEP cable (part no. 530 112) T01...T30 (1...30 m/3...99 ft.) See "Frequently ordered accessories" for cable specifications
Encode in meters if using metric stroke length. Encode in feet if using US customary stroke length.	

g	System
1	Standard

h	Output
A	Current
V	Voltage

i	Function
1	Position (1 or 2 magnets/outputs)
2	Position and speed (1 magnet and 2 outputs) Specify the maximum speed value in section <b>1</b>
3	Position and velocity (1 magnet and 2 outputs) Specify the maximum velocity value in section <b>1</b>
4	Position and reverse position (1 magnet and 2 outputs)
5	Position and temperature inside the sensor electronics housing (1 magnet and 2 outputs)
6	Differential (2 magnets and 1 output)

j	Options
0	Standard
3	Over range output mode

k	Output range
0	0...10 VDC or 4...20 mA
1	10...0 VDC or 20...4 mA
2	-10...+10 VDC or 0...20 mA
3	+10...-10 VDC or 20...0 mA
V	0...10 VDC for position, -10...+10 VDC for velocity

l	Max. speed or velocity value
<b>(optional: use when i "Function" is 2 or 3)</b>	
<input type="checkbox"/>	For metric stroke lengths encode speed or velocity in m/s for the values 0.01 to 9.99 m/s (001...999)
<input type="checkbox"/>	For US customary stroke lengths encode speed or velocity in inches/s for the values 1 to 400 in./s (001...400)
To get a speed or velocity output of 0.025 m/s or 10 m/s for the R-Series V Analog, enter code (00E) for 0.025 m/s or (A00) for 10.0 m/s in the order code.	

NOTICE
<ul style="list-style-type: none"> <li>Specify the number of magnets for your application and order the magnets separately.</li> <li>The number of magnets is limited by the stroke length. The minimum allowed distance between magnets (i.e. front face of one to the front face of the next one) is 75 mm (3 in.).</li> <li>Use magnets of the same type for differential/multi-position measurement.</li> </ul>

## DELIVERY



### RH5-B:

- Base unit (without flange & rod assembly)
- 3 × socket screws M4×59

### RH5-J/-M/-S/-T:

- Sensor
- O-ring

Accessories have to be ordered separately.

Manuals, Software & 3D Models available at:  
[www.temposonics.com](http://www.temposonics.com)

## GLOSSARY

### A

#### Analog output

For a sensor with analog output, the measured value is output as an analog voltage signal or current signal.

### D

#### Differential

For differential measurement, the distance between the two position magnets is output as a value.

(→ multi-position measurement)

### M

#### Max. speed or velocity value

For speed or velocity, the output value generated is scaled based on the maximum speed or velocity value indicated in the order code.

#### Measuring direction

- Forward: Values increasing from sensor electronics housing to rod end/profile end
- Reverse: Values decreasing from sensor electronics housing to rod end/profile end

#### Multi-position measurement

During the measurement cycle, the positions of every magnet on the sensor are simultaneously reported. The velocity or speed is continuously calculated based on these changing position values as the magnets are moved.

### O

#### Over range output mode

When enabled this mode allows the position output values to continue to increase or decrease when the magnet travels beyond the active stroke range.

### R

#### Resolution

The sensor precisely measures time to provide the position measurement. For the analog output the measured time value is converted into an analog voltage signal or current signal using a high-performance **D**igital to **A**nalog **C**onverter (DAC) having 16 bits of resolution.

### S

#### Speed

The output value for speed indicates how fast the position magnet is being moved, independent of the measuring direction. (→ Velocity)

### T

#### Temperature inside the sensor electronics housing

The temperature inside the sensor electronics housing is reported as an analog voltage signal or current signal. For each output range, the 0 % output value has the factory default setpoint at -40 °C, and the 100 % output value has the default setpoint at +100 °C.

Note: A dedicated temperature chip is used for the output signal and its values may vary from those reported on the TempoLink® application screen.

### V

#### Velocity

The output value for velocity indicates how fast the position magnet is being moved, and in which direction. (→ Speed)

**UNITED STATES**  
**Temposonics, LLC**  
Americas & APAC Region  
3001 Sheldon Drive  
Cary, N.C. 27513  
Phone: +1 919 677-0100  
E-mail: info.us@temposonics.com

**GERMANY**  
**Temposonics**  
**GmbH & Co. KG**  
EMEA Region & India  
Auf dem Schüffel 9  
58513 Lüdenscheid  
Phone: +49 2351 9587-0  
E-mail: info.de@temposonics.com

**ITALY**  
Branch Office  
Phone: +39 030 988 3819  
E-mail: info.it@temposonics.com

**FRANCE**  
Branch Office  
Phone: +33 6 14 060 728  
E-mail: info.fr@temposonics.com

**UK**  
Branch Office  
Phone: +44 79 21 83 05 86  
E-mail: info.uk@temposonics.com

**SCANDINAVIA**  
Branch Office  
Phone: +46 70 29 91 281  
E-mail: info.sca@temposonics.com

**CHINA**  
Branch Office  
Phone: +86 21 3405 7850  
E-mail: info.cn@temposonics.com

**JAPAN**  
Branch Office  
Phone: +81 3 6416 1063  
E-mail: info.jp@temposonics.com

**Document Part Number:**  
552061 Rev C (EN) 08/2023



**temposonics.com**