



Temposonics

AN AMPHENOL COMPANY

Operation Manual

R-Series V Analog

Magnetostrictive Linear Position Sensors



V
THE NEW GENERATION

Table of contents

1. Introduction	3
1.1 Purpose and use of this manual	3
1.2 Used symbols and warnings	3
2. Safety instructions	3
2.1 Intended use	3
2.2 Foreseeable misuse	3
2.3 Installation, commissioning and operation	4
2.4 Safety instructions for use in explosion-hazardous areas	4
2.5 Warranty	4
2.6 Return	4
3. Identification	5
3.1 Order code of Temposonics® RP5	5
3.2 Order code of Temposonics® RH5	7
3.3 Order code of Temposonics® RM5	9
3.4 Order code of Temposonics® RFV	11
3.5 Order code of Temposonics® RDV	13
3.6 Nameplate	15
3.7 Approvals	15
3.8 Scope of delivery	15
4. Product description	16
4.1 Functionality and system design	16
4.2 Installation and design of Temposonics® RP5	17
4.3 Installation and design of Temposonics® RH5	19
4.4 Installation and design of Temposonics® RM5	22
4.5 Installation and design of Temposonics® RFV	24
4.6 Installation and design of Temposonics® RDV	29
4.7 Magnet installation	35
4.8 Replacement of base unit	40
4.9 Electrical connection	43
4.10 Frequently ordered accessories for Temposonics® RP5	45
4.11 Frequently ordered accessories for Temposonics® RH5	46
4.12 Frequently ordered accessories for Temposonics® RM5	47
4.13 Frequently ordered accessories for Temposonics® RFV	48
4.14 Frequently ordered accessories for Temposonics® RDV	50
4.15 Frequently ordered accessories for Analog output	52
5. Commissioning	55
5.1 Getting started	55
5.2 Analog output options	55
5.3 LED status	55
5.4 Adjustment of sensor settings on-site	56
6. Maintenance and troubleshooting	65
6.1 Error conditions, troubleshooting	65
6.2 Maintenance	65
6.3 Repair	65
6.4 List of spare parts	65
6.5 Transport and storage	65
7. Removal from service/dismantling	65
8. Technical data	66
8.1 Technical data of Temposonics® RP5	66
8.2 Technical data of Temposonics® RH5	68
8.3 Technical data of Temposonics® RM5	70
8.4 Technical data of Temposonics® RFV	72
8.5 Technical data of Temposonics® RDV	74
9. Appendix I	76
10. Appendix II	77
11. Glossary	78

1. Introduction

1.1 Purpose and use of this manual

Before starting the operation of Temposonics® position sensors, read this documentation thoroughly and follow the safety information. Keep this manual for future reference!

The content of this technical documentation and of its appendices is intended to provide information on mounting, installation and commissioning by qualified automation personnel ¹ or instructed service technicians who are familiar with the project planning and dealing with Temposonics® sensors.

1.2 Used symbols and warnings

Warnings are intended for your personal safety and for avoidance of damage to the described product or connected devices. In this documentation, safety information and warnings to avoid danger that might affect the life and health of operating or service personnel or cause material damage are highlighted by the pictogram defined below.

Symbol	Meaning
NOTICE	This symbol is used to point to situations that may lead to material damage, but not to personal injury.

2. Safety instructions

2.1 Intended use

This product may be used only for the applications defined under item 1 and only in conjunction with the third-party devices and components recommended or approved by Temposonics. As a prerequisite of proper and safe operation the product requires correct transport, storage, mounting and commissioning and must be operated with utmost care.

- The sensor systems of all Temposonics® series are intended exclusively for measurement tasks encountered in industrial, commercial and laboratory applications. The sensors are considered as system accessories and must be connected to suitable evaluation electronics, e.g. a PLC, IPC, indicator or other electronic control unit.

^{1/} The term "qualified technical personnel" characterizes persons who:

- are familiar with the safety concepts of automation technology applicable to the particular project
- are competent in the field of electromagnetic compatibility (EMC)

2.2 Foreseeable misuse

Foreseeable misuse	Consequence
Wrong sensor connection	The sensor will not work properly or can be damaged
Operate the sensor out of the operating temperature range	No signal output – the sensor can be damaged
Power supply is out of the defined range	Signal output is wrong/ no signal output/ the sensor will be damaged
Position measurement is influenced by an external magnetic field	Signal output is wrong
Cables are damaged	Short circuit – the sensor can be damaged/sensor does not respond
Spacers are missing/ installed in a wrong order	Error in position measurement
Wrong connection of ground/shield	Signal output is disturbed – the electronics can be damaged
Use of a magnet that is not specified by Temposonics	Error in position measurement

Do not alter the sensor afterwards.
→ The sensor might be damaged.

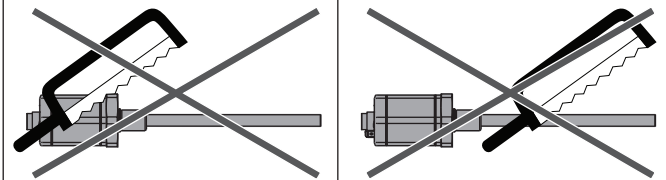

Do not step on the sensor.
→ The sensor might be damaged.

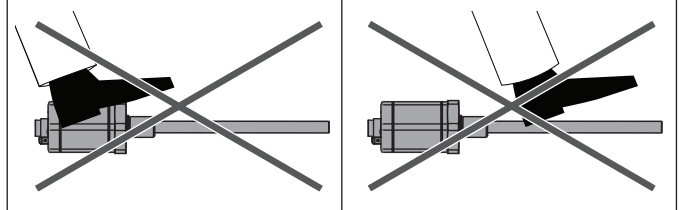

- have received adequate training for commissioning and service operations
- are familiar with the operation of the device and know the information required for correct operation provided in the product documentation

2.3 Installation, commissioning and operation

The position sensors must be used only in technically safe condition. To maintain this condition and to ensure safe operation, installation, connection and service, work may be performed only by qualified technical personnel. If danger of injury to persons or of damage to operating equipment is caused by sensor failure or malfunction, additional safety measures such as plausibility checks, limit switches, EMERGENCY STOP systems, protective devices etc. are required. In the event of trouble, shut down the sensor and protect it against accidental operation.

Safety instructions for commissioning

To maintain the sensor's operability, it is mandatory to follow the instructions given below.

1. Protect the sensors against mechanical damage during installation and operation.
2. Do not open or dismantle the sensors.
3. Connect the sensors very carefully and pay attention to the polarity of connections and power supply.
4. Use only approved power supplies.
5. Ensure the sensor is operating within the defined limits for supply voltage, environmental conditions, etc..
6. Check the function of the sensors regularly and provide documentation of the checks.
7. Before applying power, ensure that nobody's safety is jeopardized by starting machines.

2.4 Safety instructions for use in explosion-hazardous areas

The sensors are not suitable for operation in explosion-hazardous areas.

2.5 Warranty

Temposonics grants a warranty period² for the position sensors and supplied accessories relating to material defects and faults that occur despite correct use in accordance with the intended application. The Temposonics obligation is limited to repair or replacement of any defective part of the unit. No warranty can be provided for defects that are due to improper use or above average stress of the product as well as for wear parts. Under no circumstances will Temposonics accept liability in the event of offense against the warranty rules, no matter if these have been assured or expected, even in case of fault or negligence of the company.

Temposonics explicitly excludes any further warranties. Neither the company's representatives, agents, dealers nor employees are authorized to increase or change the scope of warranty.

2.6 Return

For diagnostic purposes, the sensor can be returned to Temposonics or a repair facility explicitly authorized by Temposonics. Any shipment cost is the responsibility of the sender². For a corresponding form, see chapter "9. Appendix I" on page 76.

NOTICE

When returning sensors, place protective caps on male and female connectors of the sensor. For pigtail cables, place the cable ends in a static shielding bag for electrostatic discharge (ESD) protection. Fill the outer packaging around the sensor completely to prevent damage during transport.

2/ See also applicable Temposonics terms of sales and delivery on:
www.temposonics.com

3. Identification

3.1 Order code of Temposonics® RP5

1	2	3	4	5	6	7	8	9	10	11	12	13	14	15	16	17	18	19	20	21	22	23	
R	P	5													1								
a			b	c	d					e	f			g	h	i	j	k	l				

optional

a	Sensor model		
R	P	5	Profile

b	Design
G	Magnet slider backlash free (part no. 253 421), suitable for internal linearization
L	Block magnet L (part no. 403 448)
M	U-magnet OD33 (part no. 251 416-2), suitable for internal linearization
N	Magnet slider longer ball-jointed arm (part no. 252 183), suitable for internal linearization
O	No position magnet
S	Magnet slider joint at top (part no. 252 182), suitable for internal linearization
V	Magnet slider joint at front (part no. 252 184), suitable for internal linearization

c	Mechanical options
A	Standard
V	Fluorelastomer seals for the sensor electronics housing

d	Stroke length				
X	X	X	X	M	0025...6350 mm
Standard stroke length (mm)		Ordering steps			
25... 500 mm		25 mm			
500...2500 mm		50 mm			
2500...5000 mm		100 mm			
5000...6350 mm		250 mm			
X	X	X	X	U	001.0...250.0 in.
Standard stroke length (in.)		Ordering steps			
1... 20 in.		1.0 in.			
20...100 in.		2.0 in.			
100...200 in.		4.0 in.			
200...250 in.		10.0 in.			

Non-standard stroke lengths are available; must be encoded in 5 mm/0.1 in. increments.

e	Number of magnets	
0	X	01...02 Position(s) (1...2 magnet(s))

f	Connection type		
Connector			
D	3	4	M12 male connector (5 pin)
D	6	0	M16 male connector (6 pin)
Angled cable outlet			
E	X	X	XX m/ft. PVC cable (part no. 530 032) E01...E30 (1...30 m/3...99 ft.) See "Frequently ordered accessories" for cable specifications
G	X	X	XX m/ft. FEP cable (part no. 530 157) G01...G30 (1...30 m/3...99 ft.) See "Frequently ordered accessories" for cable specifications
L	X	X	XX m/ft. PUR cable (part no. 530 052) L01...L30 (1...30 m/3...99 ft.) (Note the temperature range of the cable!) See "Frequently ordered accessories" for cable specifications
U	X	X	XX m/ft. Silicone cable (part no. 530 176) U01...U30 (1...30 m/3...99 ft.) See "Frequently ordered accessories" for cable specifications
Straight cable outlet			
H	X	X	XX m/ft. PUR cable (part no. 530 052) H01...H30 (1...30 m/3...99 ft.) (Note the temperature range of the cable!) See "Frequently ordered accessories" for cable specifications
R	X	X	XX m/ft. PVC cable (part no. 530 032) R01...R30 (1...30 m/3...99 ft.) See "Frequently ordered accessories" for cable specifications
T	X	X	XX m/ft. PTFE cable (part no. 530 112) T01...T30 (1...30 m/3...99 ft.) See "Frequently ordered accessories" for cable specifications
Encode in meters if using metric stroke length. Encode in feet if using US customary stroke length.			

g System	
1	Standard

h Output	
A	Current
V	Voltage

i Function	
1	Position (1 or 2 magnets/outputs)
2	Position and speed (1 magnet and 2 outputs) Specify the maximum speed value in section l
3	Position and velocity (1 magnet and 2 outputs) Specify the maximum velocity value in section l
4	Position and reverse position (1 magnet and 2 outputs)
5	Position and temperature inside the sensor electronics housing (1 magnet and 2 outputs)
6	Differential (2 magnets and 1 output)

j Options	
0	Standard
3	Over range output mode

k Output range	
0	0...10 VDC or 4...20 mA
1	10...0 VDC or 20...4 mA
2	-10...+10 VDC or 0...20 mA
3	+10...-10 VDC or 20...0 mA
V	0...10 VDC for position, -10...+10 VDC for velocity

l Max. speed or velocity value	
(optional: use when i "Function" is 2 or 3)	
<input type="text"/>	For metric stroke lengths encode speed or velocity in m/s for the values 0.01 to 9.99 m/s (001...999) For US customary stroke lengths encode speed or velocity in inches/s for the values 1 to 400 in./s (001...400)
To get a speed or velocity output of 0.025 m/s or 10 m/s for the R-Series V Analog, enter code (00E) for 0.025 m/s or (A00) for 10.0 m/s in the order code.	

NOTICE

- For RP5, the magnet selected in **b** "Design" is included in the scope of delivery. Specify the number of magnets for your application. For multi-position measurements with more than 1 magnet order the other magnets separately.
- The number of magnets is limited by the stroke length. The minimum allowed distance between magnets (i.e. front face of one to the front face of the next one) is 75 mm (3 in.).
- Use magnets of the same type for differential/multi-position measurement.

3.2 Order code of Temposonics® RH5

1	2	3	4	5	6	7	8	9	10	11	12	13	14	15	16	17	18	19	20	21	22	23	
R	H	5													1								
a			b	c	d					e	f			g	h	i	j	k	l				

optional

a	Sensor model
R H 5	Rod

b	Design
B	Base unit (only for replacement)
J	Threaded flange M22×1.5-6g (rod Ø 12.7 mm), stroke length: 25...5900 mm (1...232 in.)
M	Threaded flange M18×1.5-6g (standard)
S	Threaded flange ¾"-16 UNF-3A (standard)
T	Threaded flange ¾"-16 UNF-3A (with raised-face)

c	Mechanical options
A	Standard
B	Bushing on rod end (only for design »M«, »S« & »T«)
M	Thread M4 at rod end (only for design »M«, »S« & »T«)
V	Fluorelastomer seals for the sensor electronics housing

d	Stroke length	
X X X X M	0025...7620 mm	
Standard stroke length (mm)		Ordering steps
25... 500 mm		5 mm
500... 750 mm		10 mm
750...1000 mm		25 mm
1000...2500 mm		50 mm
2500...5000 mm		100 mm
5000...7620 mm		250 mm
X X X X U	001.0...300.0 in.	
Standard stroke length (in.)		Ordering steps
1... 20 in.		0.2 in.
20... 30 in.		0.4 in.
30... 40 in.		1.0 in.
40...100 in.		2.0 in.
100...200 in.		4.0 in.
200...300 in.		10.0 in.
Non-standard stroke lengths are available; must be encoded in 5 mm/0.1 in. increments.		

e	Number of magnets
0 X	01...02 Position(s) (1...2 magnet(s))

f	Connection type
Connector	
D 3 4	M12 male connector (5 pin)
D 6 0	M16 male connector (6 pin)
Angled cable outlet	
E X X	XX m/ft. PVC cable (part no. 530 032) E01...E30 (1...30 m/3...99 ft.) See "Frequently ordered accessories" for cable specifications
G X X	XX m/ft. FEP cable (part no. 530 157) G01...G30 (1...30 m/3...99 ft.) See "Frequently ordered accessories" for cable specifications
L X X	XX m/ft. PUR cable (part no. 530 052) L01...L30 (1...30 m/3...99 ft.) (Note the temperature range of the cable!) See "Frequently ordered accessories" for cable specifications
U X X	XX m/ft. Silicone cable (part no. 530 176) U01...U30 (1...30 m/3...99 ft.) See "Frequently ordered accessories" for cable specifications
Straight cable outlet	
H X X	XX m/ft. PUR cable (part no. 530 052) H01...H30 (1...30 m/3...99 ft.) (Note the temperature range of the cable!) See "Frequently ordered accessories" for cable specifications
R X X	XX m/ft. PVC cable (part no. 530 032) R01...R30 (1...30 m/3...99 ft.) See "Frequently ordered accessories" for cable specifications
T X X	XX m/ft. PTFE cable (part no. 530 112) T01...T30 (1...30 m/3...99 ft.) See "Frequently ordered accessories" for cable specifications
Encode in meters if using metric stroke length. Encode in feet if using US customary stroke length.	

Temposonics® R-Series V Analog
 Operation Manual

g System	
1	Standard

h Output	
A	Current
V	Voltage

i Function	
1	Position (1 or 2 magnets/outputs)
2	Position and speed (1 magnet and 2 outputs) Specify the maximum speed value in section l
3	Position and velocity (1 magnet and 2 outputs) Specify the maximum velocity value in section l
4	Position and reverse position (1 magnet and 2 outputs)
5	Position and temperature inside the sensor electronics housing (1 magnet and 2 outputs)
6	Differential (2 magnets and 1 output)

j Options	
0	Standard
3	Over range output mode

k Output range	
0	0...10 VDC or 4...20 mA
1	10...0 VDC or 20...4 mA
2	-10...+10 VDC or 0...20 mA
3	+10...-10 VDC or 20...0 mA
V	0...10 VDC for position, -10...+10 VDC for velocity

l Max. speed or velocity value	
(optional: use when i "Function" is 2 or 3)	
<input type="checkbox"/>	For metric stroke lengths encode speed or velocity in m/s for the values 0.01 to 9.99 m/s (001...999)
<input type="checkbox"/>	For US customary stroke lengths encode speed or velocity in inches/s for the values 1 to 400 in./s (001...400)
To get a speed or velocity output of 0.025 m/s or 10 m/s for the R-Series V Analog, enter code (00E) for 0.025 m/s or (A00) for 10.0 m/s in the order code.	

NOTICE

- Specify the number of magnets for your application and order the magnets separately.
- The number of magnets is limited by the stroke length. The minimum allowed distance between magnets (i.e. front face of one to the front face of the next one) is 75 mm (3 in.).
- Use magnets of the same type for differential/multi-position measurement.

3.3 Order code of Temposonics® RM5

1	2	3	4	5	6	7	8	9	10	11	12	13	14	15	16	17	18	19	20	21	22	23	
R	M	5		A											1								
a			b	c	d					e	f			g	h	i	j	k	l				

optional

a	Sensor model
R M 5	Super shield housing

b	Design
B	Base unit (only for replacement/only with connection type D34)
M	Threaded flange M18×1.5-6g (standard)
S	Threaded flange ¾"-16 UNF-3A (standard)

c	Mechanical options
A	Standard

d	Stroke length
X X X X M	0025...7615 mm

Standard stroke length (mm)	Ordering steps
25... 500 mm	5 mm
500... 750 mm	10 mm
750...1000 mm	25 mm
1000...2500 mm	50 mm
2500...5000 mm	100 mm
5000...7615 mm	250 mm

X X X X U	001.0...299.8 in.
-----------	-------------------

Standard stroke length (in.)	Ordering steps
1... 20 in.	0.2 in.
20... 30 in.	0.4 in.
30... 40 in.	1.0 in.
40...100 in.	2.0 in.
100...200 in.	4.0 in.
200...299.8 in.	10.0 in.

Non-standard stroke lengths are available; must be encoded in 5 mm/0.1 in. increments.

e	Number of magnets
0 X	01...02 Position(s) (1...2 magnet(s))

f	Connection type
D 3 4	M12 male connector (5 pin) (only for RM5-B)

H X X	XX m PUR cable (part no. 530 052) H01...H30 (1...30 m/3...99 ft.) (Note the temperature range of the cable!) See "Frequently ordered accessories" for cable specifications
-------	---

R X X	XX m PVC cable (part no. 530 032) R01...R30 (1...30 m/3...99 ft.) See "Frequently ordered accessories" for cable specifications
-------	---

T X X	XX m FEP cable (part no. 530 112) T01...T30 (1...30 m/3...99 ft.) See "Frequently ordered accessories" for cable specifications
-------	---

Encode in meters if using metric stroke length.
Encode in feet if using US customary stroke length.

g	System
1	Standard

h	Output
A	Current
V	Voltage

i	Function
---	----------

1	Position (1 or 2 magnets/outputs)
---	-----------------------------------

2	Position and speed (1 magnet and 2 outputs) Specify the maximum speed value in section I
---	---

3	Position and velocity (1 magnet and 2 outputs) Specify the maximum velocity value in section I
---	---

4	Position and reverse position (1 magnet and 2 outputs)
---	--

5	Position and temperature inside the sensor electronics housing (1 magnet and 2 outputs)
---	--

6	Differential (2 magnets and 1 output)
---	---------------------------------------

j	Options
---	---------

0	Standard
---	----------

3	Over range output mode
---	------------------------

Temposonics® R-Series V Analog
 Operation Manual

k	Output range
0	0...10 VDC or 4...20 mA
1	10...0 VDC or 20...4 mA
2	-10...+10 VDC or 0...20 mA
3	+10...-10 VDC or 20...0 mA
V	0...10 VDC for position, -10...+10 VDC for velocity

I	Max. speed or velocity value
(optional: use when I "Function" is 2 or 3)	
<input type="checkbox"/> <input type="checkbox"/> <input type="checkbox"/>	For metric stroke lengths encode speed or velocity in m/s for the values 0.01 to 9.99 m/s (001...999) For US customary stroke lengths encode speed or velocity in inches/s for the values 1 to 400 in./s (001...400)
To get a speed or velocity output of 0.025 m/s or 10 m/s for the R-Series V Analog, enter code (00E) for 0.025 m/s or (A00) for 10.0 m/s in the order code.	

NOTICE

- Specify the number of magnets for your application and order the magnets separately.
- The number of magnets is limited by the stroke length. The minimum allowed distance between magnets (i.e. front face of one to the front face of the next one) is 75 mm (3 in.).
- Use magnets of the same type for differential/multi-position measurement.

3.4 Order code of Temposonics® RFV

1	2	3	4	5	6	7	8	9	10	11	12	13	14	15	16	17	18	19	20	21	22	23	
R	F	V													1								
a			b	d						e	f			g	h	i	j	k	l				

optional

a	Sensor model		
R	F	V	Flexible rod

b	Design
B	Base unit (without flange & rod assembly)
M	Threaded flange M18×1.5-6g (without rod assembly)
S	Threaded flange ¾"-16 UNF-3A (without rod assembly)

Section **c** is intentionally omitted.

d	Stroke length					
X	X	X	X	X	M	00150...20000 mm
Stroke length (mm)		Ordering steps				
150... 1000 mm		50 mm				
1000... 5000 mm		100 mm				
5000...10000 mm		250 mm				
10000...15000 mm		500 mm				
15000...20000 mm		1000 mm				
X	X	X	X	X	U	0006.0...0787.0 in.
Stroke length (in.)		Ordering steps				
6... 40 in.		2 in.				
40...197 in.		4 in.				
197...394 in.		10 in.				
394...591 in.		20 in.				
591...787 in.		40 in.				
Non standard stroke lengths are available; must be encoded in 5 mm/0.1 in. increments						

e	Number of magnets	
0	X	01...02 Position(s) (1...2 magnet(s))

f	Connection type		
Connector			
D	3	4	M12 male connector (5 pin)
D	6	0	M16 male connector (6 pin)
Angled cable outlet			
E	X	X	XX m/ft. PVC cable (part no. 530 032) E01...E30 (1...30 m/3...99 ft.) See "Frequently ordered accessories" for cable specifications
G	X	X	XX m/ft. FEP cable (part no. 530 157) G01...G30 (1...30 m/3...99 ft.) See "Frequently ordered accessories" for cable specifications
L	X	X	XX m/ft. PUR cable (part no. 530 052) L01...L30 (1...30 m/3...99 ft.) (Note the temperature range of the cable!) See "Frequently ordered accessories" for cable specifications
U	X	X	XX m/ft. Silicone cable (part no. 530 176) U01...U30 (1...30 m/3...99 ft.) See "Frequently ordered accessories" for cable specifications
Straight cable outlet			
H	X	X	XX m/ft. PUR cable (part no. 530 052) H01...H30 (1...30 m/3...99 ft.) (Note the temperature range of the cable!) See "Frequently ordered accessories" for cable specifications
R	X	X	XX m/ft. PVC cable (part no. 530 032) R01...R30 (1...30 m/3...99 ft.) See "Frequently ordered accessories" for cable specifications
T	X	X	XX m/ft. PTFE cable (part no. 530 112) T01...T30 (1...30 m/3...99 ft.) See "Frequently ordered accessories" for cable specifications
Encode in meters if using metric stroke length. Encode in feet if using US customary stroke length.			

Temposonics® R-Series V Analog
Operation Manual

g	System
1	Standard

h	Output
A	Current
V	Voltage

i	Function
1	Position (1 or 2 magnets/outputs)
2	Position and speed (1 magnet and 2 outputs) Specify the maximum speed value in section l
3	Position and velocity (1 magnet and 2 outputs) Specify the maximum velocity value in section l
4	Position and reverse position (1 magnet and 2 outputs)
5	Position and temperature inside the sensor electronics housing (1 magnet and 2 outputs)
6	Differential (2 magnets and 1 output)

j	Options
0	Standard
3	Over range output mode

k	Output range
0	0...10 VDC or 4...20 mA
1	10...0 VDC or 20...4 mA
2	-10...+10 VDC or 0...20 mA
3	+10...-10 VDC or 20...0 mA
V	0...10 VDC for position, -10...+10 VDC for velocity

l	Max. speed or velocity value
(optional: use when i "Function" is 2 or 3)	
<input type="text"/>	For metric stroke lengths encode speed or velocity in m/s for the values 0.01 to 9.99 m/s (001...999) For US customary stroke lengths encode speed or velocity in inches/s for the values 1 to 400 in./s (001...400)
To get a speed or velocity output of 0.025 m/s or 10 m/s for the R-Series V Analog, enter code (00E) for 0.025 m/s or (A00) for 10.0 m/s in the order code.	

NOTICE

- Specify the number of magnets for your application and order the magnets separately.
- The number of magnets is limited by the stroke length. The minimum allowed distance between magnets (i.e. front face of one to the front face of the next one) is 75 mm (3 in.).
- Use magnets of the same type for differential/multi-position measurement.
- RFV-B/-M and -S are without rod assembly. Always insert the flexible sensor rod in a support tube (e.g. sensor rod HD/HL/HP or HFP profile).

3.5 Order code of Temposonics® RDV

1	2	3	4	5	6	7	8	9	10	11	12	13	14	15	16	17	18	19	20	21	22	23	
R	D	V													1								
a			b	c	d					e	f			g	h	i	j	k	l				

optional

a	Design
R D V	Detached sensor electronics "Classic"

b	Design
C	Threaded flange M18×1.5-6g (A/F 46)
D	Threaded flange ¾"-16 UNF-3A (A/F 46)
M	Threaded flange M18×1.5-6g (A/F 24)
S	Pressure fit flange Ø 26.9 mm f6
T	Threaded flange ¾"-16 UNF-3A (A/F 23)

c	Mechanical options
For side cable entry	
A	PUR cable with M16 connector, 250 mm length
B	PUR cable with M16 connector, 400 mm length
C	PUR cable with M16 connector, 600 mm length
For bottom cable entry	
2	Single wires with flat connector, 65 mm length
4	Single wires with flat connector, 170 mm length
5	Single wires with flat connector, 230 mm length
6	Single wires with flat connector, 350 mm length

d	Stroke length
X X X X M	Flange »S«: 0025...2540 mm Flange »C«, »D«, »M«, »T«: 0025...5080 mm
Stroke length (mm)	Ordering steps
25... 500 mm	5 mm
500... 750 mm	10 mm
750...1000 mm	25 mm
1000...2500 mm	50 mm
2500...5080 mm	100 mm
X X X X U	Flange »S«: 001.0...100.0 in. Flange »C«, »D«, »M«, »T«: 001.0...200.0 in.
Stroke length (in.)	Ordering steps
1... 20 in.	0.2 in.
20... 30 in.	0.4 in.
30... 40 in.	1.0 in.
40...100 in.	2.0 in.
100...200 in.	4.0 in.
Non standard stroke lengths are available; must be encoded in 5 mm/0.1 in. increments	

e	Number of magnets
0 X	01...02 Position(s) (1...2 magnet(s))

f	Connection type
Connector	
D 3 4	M12 male connector (5 pin)
D 6 0	M16 male connector (6 pin)
Angled cable outlet	
E X X	XX m/ft. PVC cable (part no. 530 032) E01...E30 (1...30 m/3...99 ft.) See "Frequently ordered accessories" for cable specifications
G X X	XX m/ft. FEP cable (part no. 530 157) G01...G30 (1...30 m/3...99 ft.) See "Frequently ordered accessories" for cable specifications
L X X	XX m/ft. PUR cable (part no. 530 052) L01...L30 (1...30 m/3...99 ft.) (Note the temperature range of the cable!) See "Frequently ordered accessories" for cable specifications
U X X	XX m/ft. Silicone cable (part no. 530 176) U01...U30 (1...30 m/3...99 ft.) See "Frequently ordered accessories" for cable specifications
Straight cable outlet	
H X X	XX m/ft. PUR cable (part no. 530 052) H01...H30 (1...30 m/3...99 ft.) (Note the temperature range of the cable!) See "Frequently ordered accessories" for cable specifications
R X X	XX m/ft. PVC cable (part no. 530 032) R01...R30 (1...30 m/3...99 ft.) See "Frequently ordered accessories" for cable specifications
T X X	XX m/ft. PTFE cable (part no. 530 112) T01...T30 (1...30 m/3...99 ft.) See "Frequently ordered accessories" for cable specifications
Encode in meters if using metric stroke length. Encode in feet if using US customary stroke length.	

Temposonics® R-Series V Analog
Operation Manual

g	System
1	Standard

h	Output
A	Current
V	Voltage

i	Function
1	Position (1 or 2 magnets/outputs)
2	Position and speed (1 magnet and 2 outputs) Specify the maximum speed value in section I
3	Position and velocity (1 magnet and 2 outputs) Specify the maximum velocity value in section I
4	Position and reverse position (1 magnet and 2 outputs)
5	Position and temperature inside the sensor electronics housing (1 magnet and 2 outputs)
6	Differential (2 magnets and 1 output)

j	Options
0	Standard
3	Over range output mode

k	Output range
0	0...10 VDC or 4...20 mA
1	10...0 VDC or 20...4 mA
2	-10...+10 VDC or 0...20 mA
3	+10...-10 VDC or 20...0 mA
V	0...10 VDC for position, -10...+10 VDC for velocity

l	Max. speed or velocity value
(optional: use when i "Function" is 2 or 3)	
<input type="text"/>	For metric stroke lengths encode speed or velocity in m/s for the values 0.01 to 9.99 m/s (001...999)
<input type="text"/>	For US customary stroke lengths encode speed or velocity in inches/s for the values 1 to 400 in./s (001...400)
To get a speed or velocity output of 0.025 m/s or 10 m/s for the R-Series V Analog, enter code (00E) for 0.025 m/s or (A00) for 10.0 m/s in the order code.	

NOTICE

- Specify the number of magnets for your application and order the magnets separately.
- The number of magnets is limited by the stroke length. The minimum allowed distance between magnets (i.e. front face of one to the front face of the next one) is 75 mm (3 in.).
- Use magnets of the same type for differential/multi-position measurement.

3.6 Nameplate

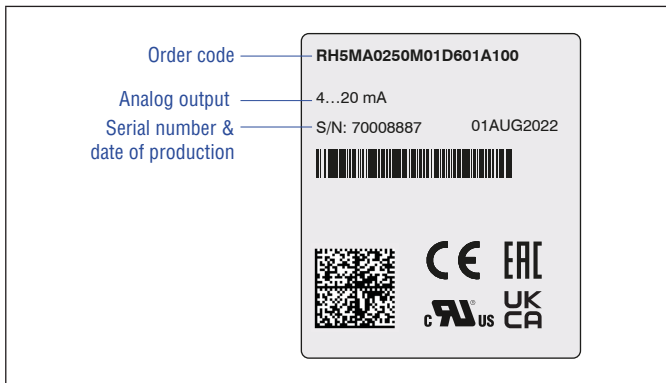

Fig. 1: Example of nameplate of R-Series V RH5 sensor with Analog output

3.7 Approvals

- CE declaration
- UKCA declaration
- EAC declaration
- UL certified

3.8 Scope of delivery

RP5 (profile sensor):

- Sensor
- Position magnet (not for RP5 with design »0«)
- 2 mounting clamps up to 1250 mm (50 in.) stroke length +
1 mounting clamp for each 500 mm (20 in.) additional stroke length

RH5 (rod sensor):

- RH5-B: Base unit (without flange & rod assembly),
3 × socket screws M4×59
- RH5-J/-M/-S/-T: Sensor, O-ring

RM5 (sensor in super shield housing):

- RM5-B: Base unit (without flange & rod assembly),
3 × socket screws M4×59
- RM5-M/-S: Sensor, O-ring

RFV (flexible rod sensor):

- RFV-B: Base unit (without flange & rod assembly),
3 × socket screws M4×59
- RFV-M/-S: Sensor (with flange & without rod assembly), O-ring

RDV (detached sensor electronics):

- RDV-C/-D/-M/-T: Sensor, O-ring
- RDV-S: Sensor, O-ring, back-up ring

4. Product description

4.1 Functionality and system design

Product designation

- Position sensor Temposonics® R-Series V

Sensor model

- Temposonics® R-Series V RP5 (profile sensor)
- Temposonics® R-Series V RH5 (rod sensor)
- Temposonics® R-Series V RM5 (sensor in super shield housing)
- Temposonics® R-Series V RFV (flexible rod sensor)
- Temposonics® R-Series V RDV (detached sensor electronics)

Stroke length

- Temposonics® R-Series V RP5: 25...6350 mm (1...250 in.)
- Temposonics® R-Series V RH5: 25...7620 mm (1...300 in.)
- Temposonics® R-Series V RM5: 25...7615 mm (1...299.8)
- Temposonics® R-Series V RFV: 150...20,000 mm (6...787 in.)
- Temposonics® R-Series V RDV: 25...5080 mm (1...200 in.)

Output signal

- Analog

Application

The Temposonics® position sensors are used for measurement and conversion of the length (position) variable in the fields of automated systems and mechanical engineering.

Principle of operation and system construction

The absolute, linear position sensors provided by Temposonics rely on the company's proprietary Temposonics® magnetostrictive technology, which can determine position with a high level of precision and robustness. Each Temposonics® position sensor consists of a ferromagnetic waveguide, a position magnet, a strain pulse converter and supporting electronics. The magnet, connected to the object in motion in the application, generates a magnetic field at its location on the waveguide. A short current pulse is applied to the waveguide. This creates a momentary radial magnetic field and torsional strain on the waveguide. The momentary interaction of the magnetic fields releases a torsional strain pulse that propagates the length of the waveguide. When the ultrasonic wave reaches the end of the waveguide it is converted into an electrical signal. Since the speed of the ultrasonic wave in the waveguide is precisely known, the time required to receive the return signal can be converted into a linear position measurement with both high accuracy and repeatability.

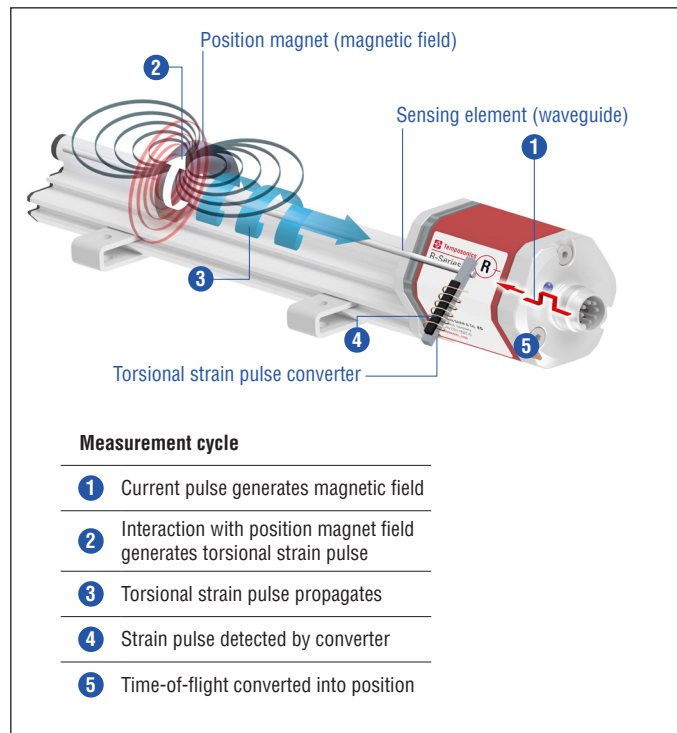

Fig. 2: Time-of-flight based magnetostrictive position sensing principle

Modular mechanical and electronic construction

- The sensor profile or rod protects the inner sensor element.
- The sensor electronics housing, a rugged aluminum construction, contains the complete electronic interface with active signal conditioning.
- The external position magnet is a permanent magnet. Mounted on the mobile machine part, it travels along the sensor profile or rod and triggers the measurement through the sensor profile/rod wall.
- The sensor can be connected directly to a control system. Its electronics generates a strictly position-proportional signal output between start and end position.

4.2 Installation and design of Temposonics® RP5

RP5-M, example: Connection type D60 (connector outlet)

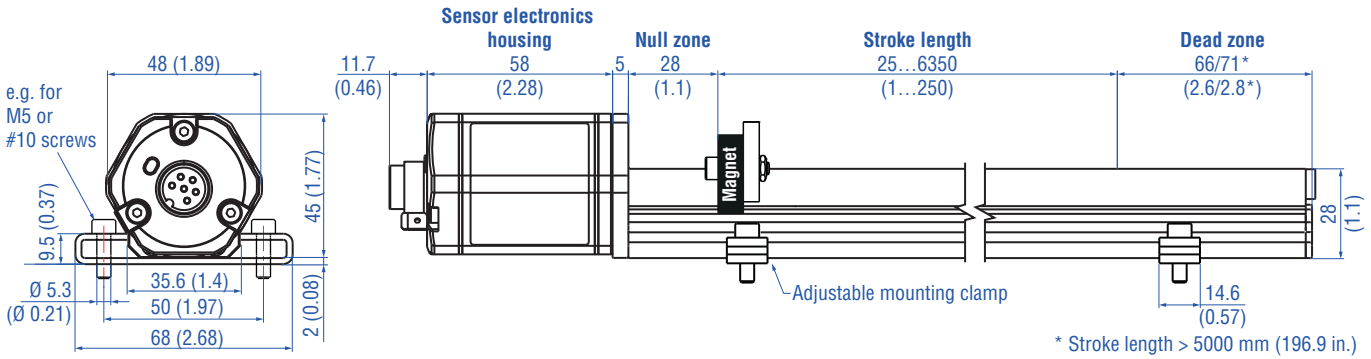

RP5-G/S, example: Connection type D34 (connector outlet)

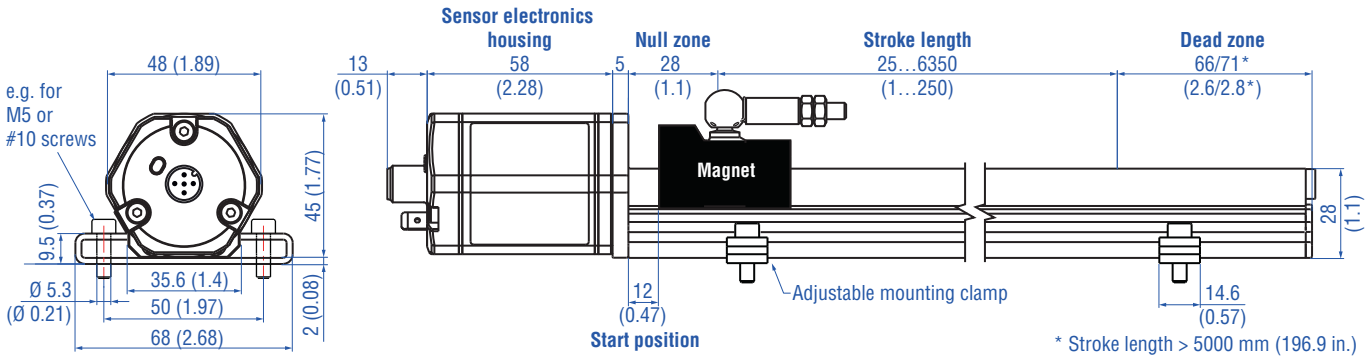

RP5-M, example: Connection type EXX/GXX/LXX/UXX (angled cable outlet)

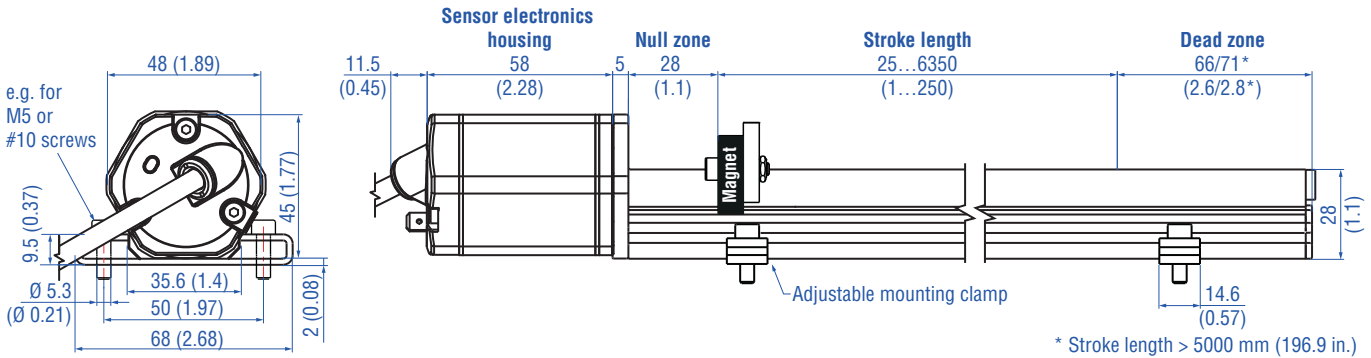

RP5-M, example: Connection type HXX/RXX/TXX (straight cable outlet)

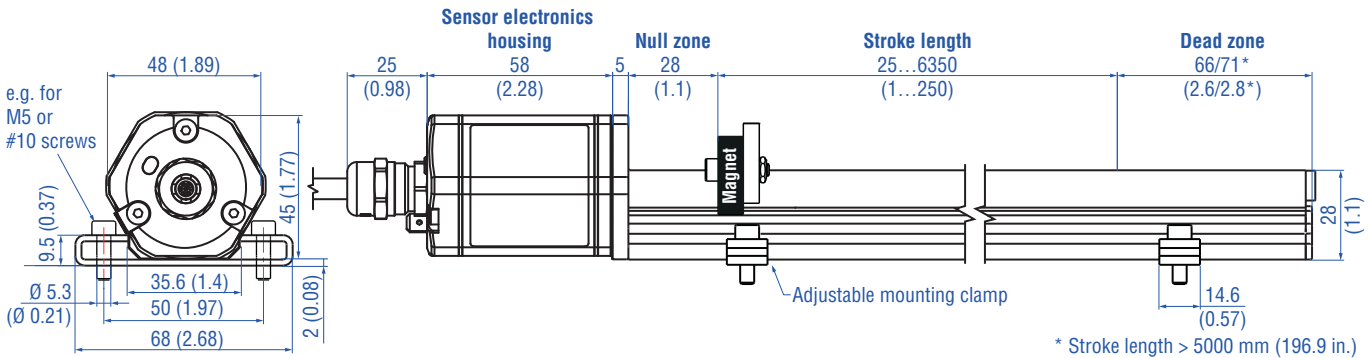

Controlling design dimensions are in millimeters and measurements in () are in inches

Fig. 3: Temposonics® RP5 with U-magnet/magnet slider

Installation of RP5

The position sensor can be installed in any position. Normally, the sensor is firmly installed and the position magnet is fastened to the mobile machine part. Thus it can travel along the sensor profile. The sensor is fitted on a flat machine surface using the mounting clamps (Fig. 4). A length-dependent number of these clamps are delivered with the sensor and must be distributed over the profile at regular distances. For fastening use M5×20 screws to DIN 6912 that should be tightened with a fastening torque of 5 Nm.

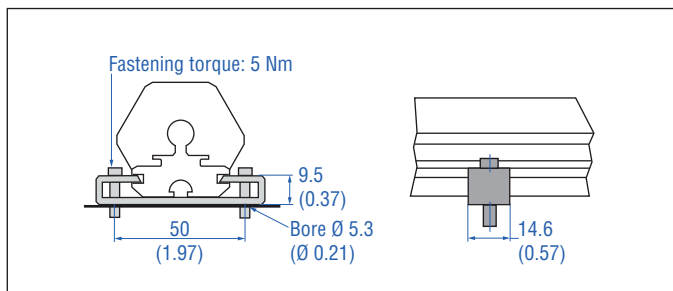

Fig. 4: Mounting clamps (part no. 400 802) with cylinder screw M5×20

Alternative:

If only limited space is available, the profile sensor can be mounted also via the T-rail in the profile bottom using a T-slot nut M5 (part no. 401 602) or a sliding block (Fig. 5).

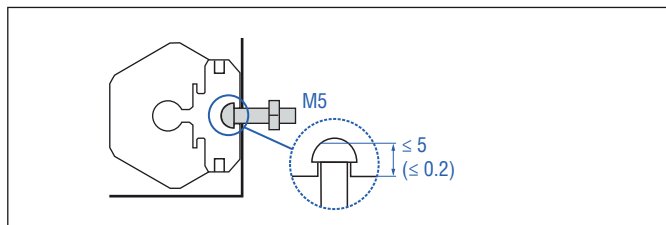
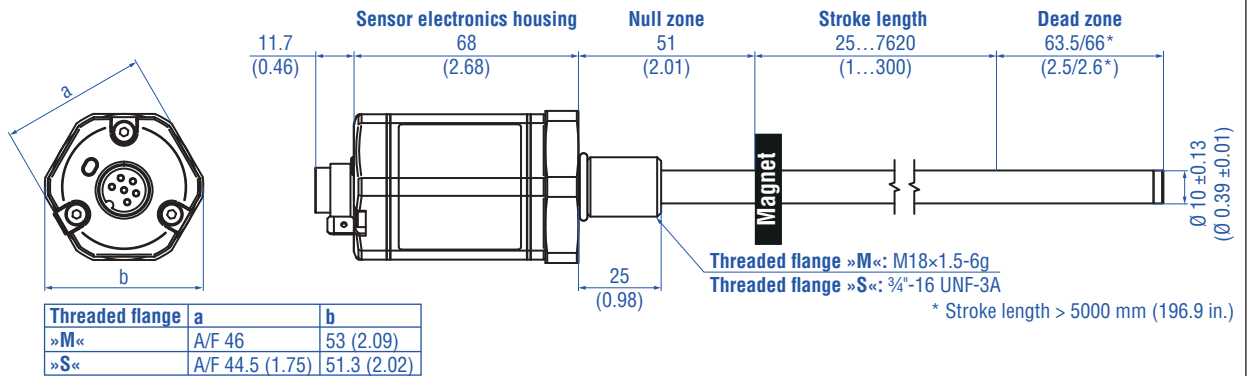

Fig. 5: T-slot nut M5 (part no. 401 602)

NOTICE
Take care to mount the sensor in an axially parallel position to avoid damage to magnet and sensor.

4.3 Installation and design of Temposonics® RH5

RH5-M/-S-A/-V – RH5 with threaded flange M18×1.5-6g or ¾"-16 UNF-3A, example: Connection type D60 (connector outlet)



RH5-T-A/-V – RH5 with threaded flange ¾"-16 UNF-3A with raised-face, example: Connection type EXX/GXX/LXX/UXX (angled cable outlet)

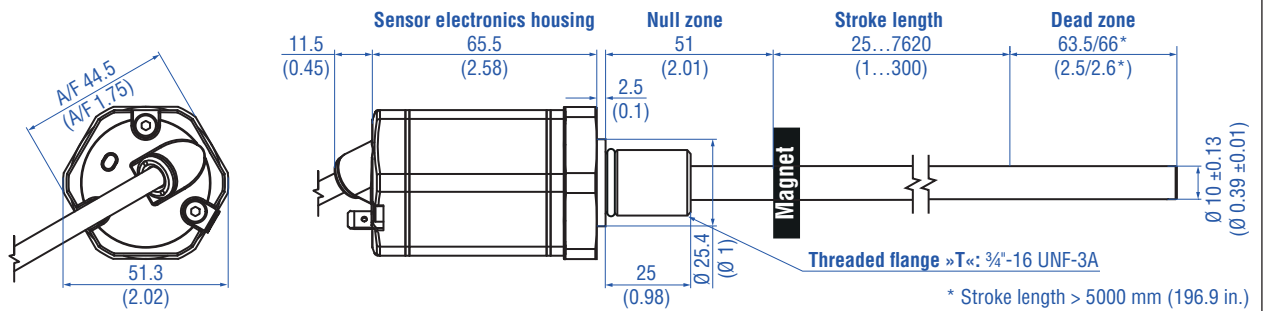

RH5-T-A/-V – RH5 with threaded flange ¾"-16 UNF-3A with raised-face, example: Connection type HXX/RXX/TXX (straight cable outlet)

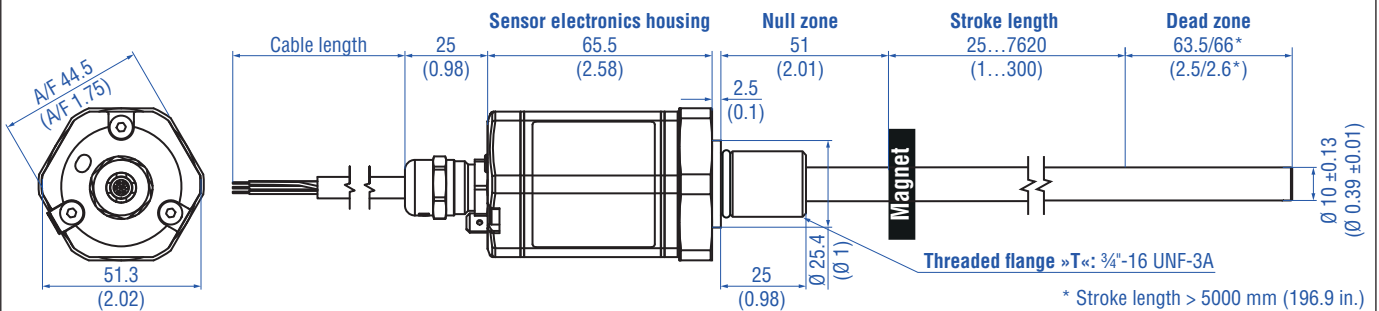

Mechanical option »B«: Bushing on rod end for threaded flange M18×1.5-6g or ¾"-16 UNF-3A

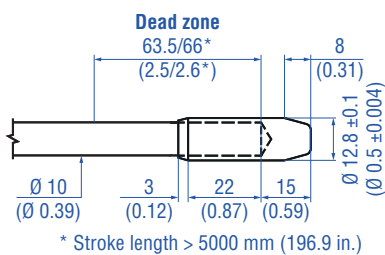

Mechanical option »M«: Thread M4 at rod end for threaded flange M18×1.5-6g or ¾"-16 UNF-3A

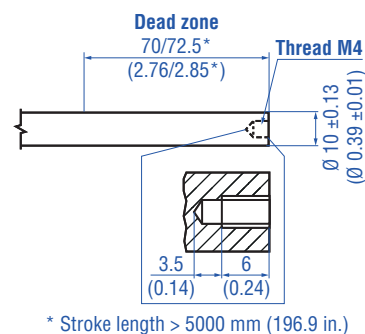

Controlling design dimensions are in millimeters and measurements in () are in inches

Fig. 6: Temposonics® RH5 with ring magnet, part 1

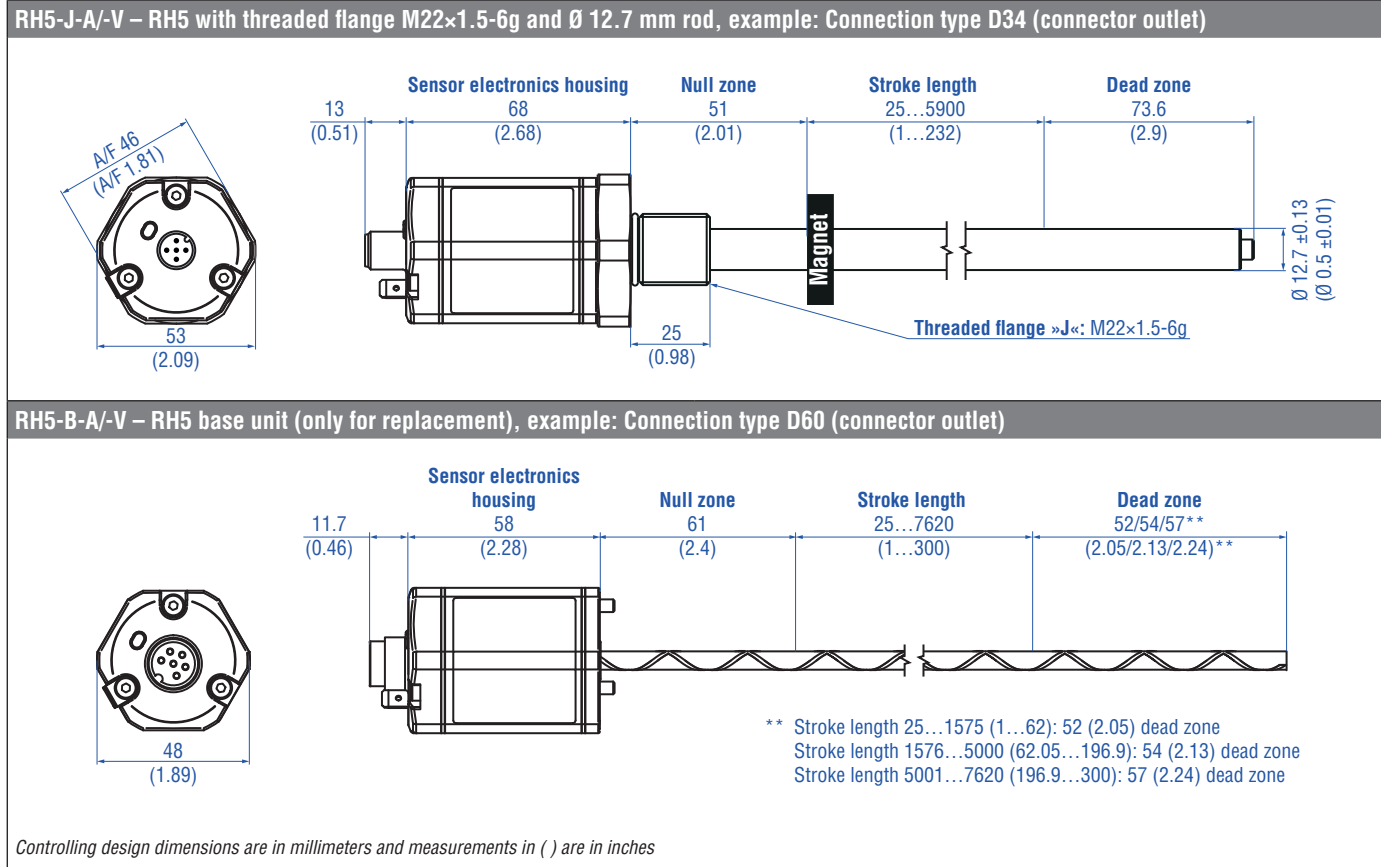

Fig. 7: Temposonics® RH5 with ring magnet, part 2

Installation of RH5 with threaded flange

Fix the sensor rod via threaded flange M18×1.5-6g, M22×1.5-6g or ¾"-16 UNF-3A. Note the fastening torque shown in Fig. 8. Lightly oil the thread before tightening.

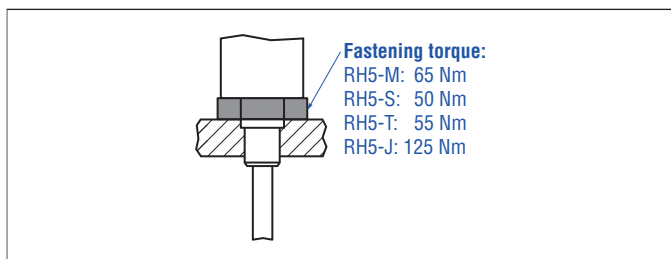

Fig. 8: Mounting example of threaded flange

Installation of a rod-style sensor in a fluid cylinder

The rod-style version has been developed for direct stroke measurement in a fluid cylinder. Mount the sensor via threaded flange or a hex nut.

- Mounted on the face of the piston, the position magnet travels over the rod without touching it and indicates the exact position through the rod wall – independent of the hydraulic fluid.

- The pressure resistant sensor rod is installed into a bore in the piston rod.
- The base unit is mounted by means of three screws. It is the only part that needs to be replaced if servicing is required, i.e. the hydraulic circuit remains closed. For more information see chapter "4.8.1 Replacement of base unit on the RH5/RfV model" on page 40.

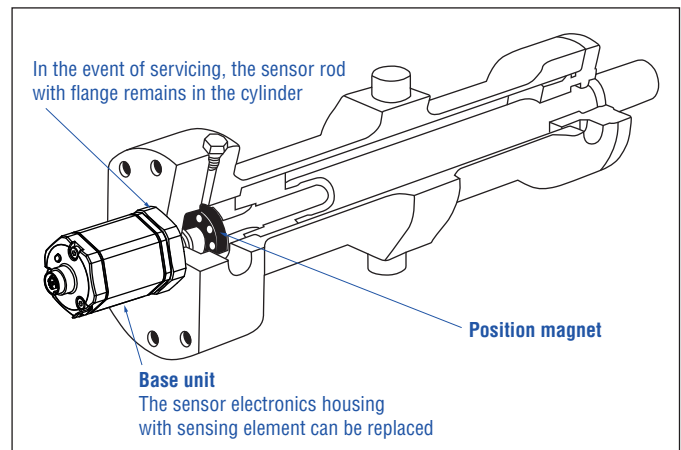

Fig. 9: Sensor in cylinder

Hydraulics sealing

There are two ways to seal the flange contact surface (Fig. 10):

1. A sealing by using an O-ring (e.g. 22.4 × 2.65 mm (0.88 × 0.1 in.), 25.07 × 2.62 mm (0.99 × 0.1 in.)) in a cylinder end cap groove.
2. A sealing by using an O-ring in the flange undercut.
 - For threaded flange (3/4"-16 UNF-3A):
O-ring 16.4 × 2.2 mm (0.65 × 0.09 in.) (part no. 560 315)
 - For threaded flange (M18×1.5-6g):
O-ring 15.3 × 2.2 mm (0.60 × 0.09 in.) (part no. 401 133)
 - For threaded flange (M22×1.5-6g):
O-ring 19.3 × 2.2 mm (0.76 × 0.09 in.) (part no. 561 337)

In the case of threaded flanges M18×1.5-6g or M22×1.5-6g, provide a screw hole based on ISO 6149-1 (Fig. 11). See ISO 6149-1 for further information.

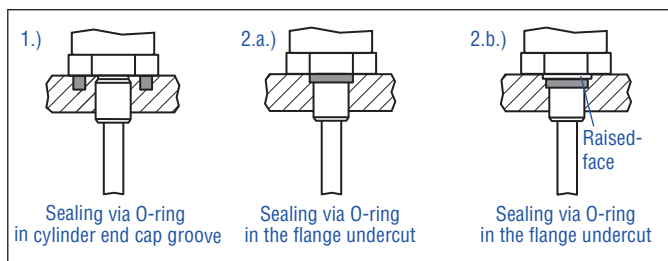

Fig. 10: Possibilities of sealing for threaded flange standard 1. + 2.a. (RH5-J/-M/-S) and for threaded flange with raised-face 2.b. (RH5-T)

- Seat the flange contact surface completely on the cylinder mounting surface.
- The cylinder manufacturer determines the pressure-resistant gasket (copper gasket, O-ring, etc.).
- The position magnet should not grind on the sensor rod.
- The piston rod drilling
 (RH5-M/-S/-T-A/-M/-V with rod Ø 10 mm: ≥ Ø 13 mm (≥ Ø 0.51 in.);
 RH5-M/-S/-T-B with rod Ø 10 mm: ≥ Ø 16 mm (≥ Ø 0.63 in.);
 RH5-J-A/-V with rod Ø 12.7 mm: ≥ Ø 16 mm (≥ Ø 0.63 in.))
 depends on the pressure and piston speed.
- Adhere to the information relating to operating pressure.
- Protect the sensor rod against wear.

Notice for metric threaded flanges									
Thread (d ₁ ×P)	d ₂	d ₃	d ₄	d ₅ +0.1 0	L ₁ +0.4 0	L ₂	L ₃	L ₄	Z° ±1°
RH5-M-A/-M/-V									
M18×1.5-6g	55	≥ 13	24.5	19.8	2.4	28.5	2	26	15°
RH5-M-B									
M18×1.5-6g	55	≥ 16	24.5	19.8	2.4	28.5	2	26	15°
RH5-J-A/-V									
M22×1.5-6g	55	≥ 16	27.5	23.8	2.4	28.5	2	26	15°

Controlling design dimensions are in millimeters

Fig. 11: Notice for metric threaded flange M18×1.5-6g/M22×1.5-6g based on DIN ISO 6149-1

4.4 Installation and design of Temposonics® RM5

RM5-M/S – RM5 with threaded flange M18×1.5 or ¾"-16 UNF-3A, example: Connection type HXX/RXX/TXX (cable outlet)

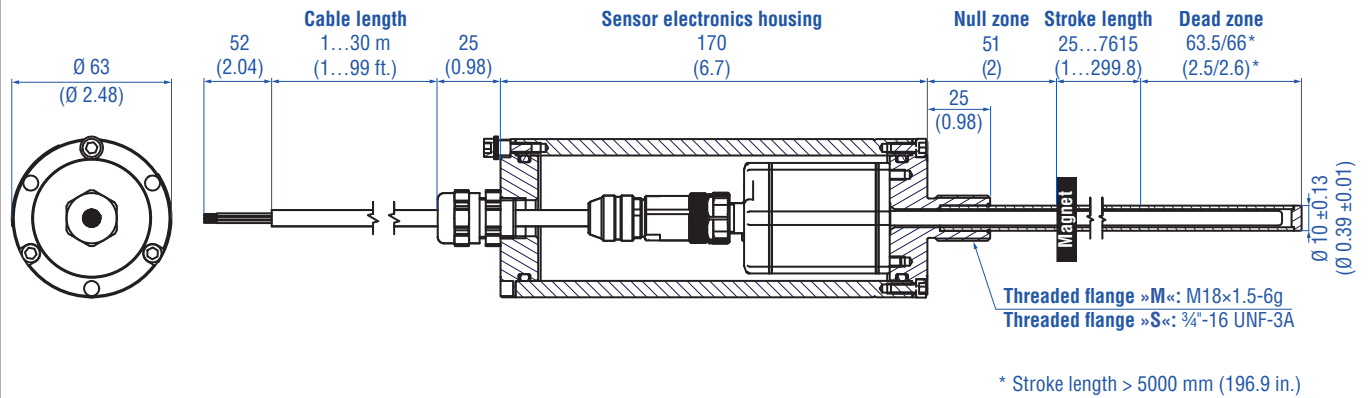

Controlling design dimensions are in millimeters and measurements in () are in inches

Fig. 12: Temposonics® RM5 with ring magnet

Installation of RM5 with threaded flange

Fix the sensor rod via threaded flange M18×1.5-6g or ¾"-16 UNF-3A. Note the fastening torque shown in Fig. 13. Lightly oil the thread before tightening.

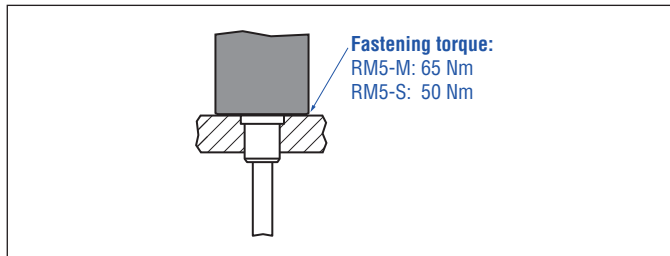

Fig. 13: Mounting example of threaded flange

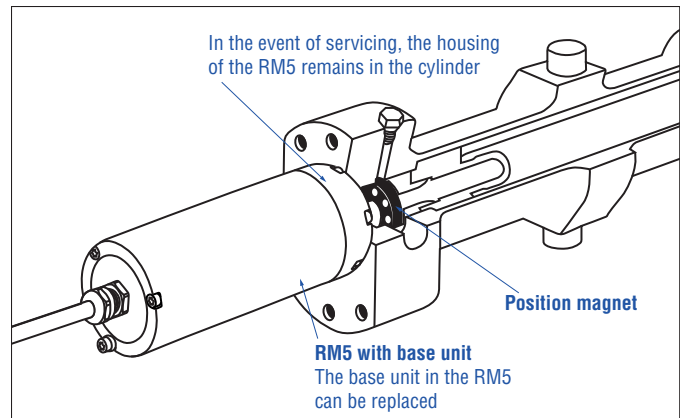

Fig. 14: RM5 sensor in cylinder

Installation of a rod-style sensor in a fluid cylinder

The rod-style version has been developed for direct stroke measurement in a fluid cylinder. Mount the sensor via threaded flange or a hex nut.

- Mounted on the face of the piston, the position magnet travels over the rod without touching it and indicates the exact position through the rod wall – independent of the hydraulic fluid.
- The pressure resistant sensor rod is installed into a bore in the piston rod.
- The base unit inside the RM5 is mounted by means of three screws. It is the only part that needs to be replaced if servicing is required, i.e. the hydraulic circuit remains closed. For more information see chapter "4.8.2 Replacement of base unit on the RM5 model" on page 41.

Hydraulics sealing

There are two ways to seal the flange contact surface (Fig. 15):

1. A sealing by using an O-ring (e.g. 22.4 × 2.65 mm (0.88 × 0.1 in.), 25.07 × 2.62 mm (0.99 × 0.1 in.)) in a cylinder end cap groove.
2. A sealing by using an O-ring in the flange undercut.

For threaded flange (¾"-16 UNF-3A):

O-ring 16.4 × 2.2 mm (0.65 × 0.09 in.) (part no. 560 315)

For threaded flange (M18×1.5-6g):

O-ring 15.3 × 2.2 mm (0.60 × 0.09 in.) (part no. 401 133)

In the case of threaded flange M18×1.5-6g provide a screw hole based on ISO 6149-1 (Fig. 16). See ISO 6149-1 for further information.

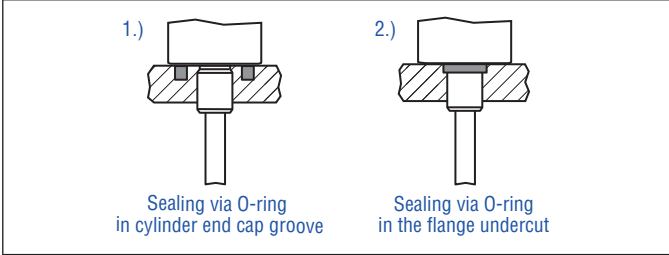

Fig. 15: Possibilities of sealing

- Seat the flange contact surface completely on the cylinder mounting surface.
- The cylinder manufacturer determines the pressure-resistant gasket (copper gasket, O-ring, etc.).
- The position magnet should not grind on the sensor rod.
- The piston rod drilling (RM5-M/-S with rod \varnothing 10 mm: $\geq \varnothing$ 13 mm ($\geq \varnothing$ 0.51 in.) depends on the pressure and piston speed.
- Adhere to the information relating to operating pressure.
- Protect the sensor rod against wear.

Notice for metric threaded flanges

Thread ($d_1 \times P$)	d_2	d_3	d_4	d_5 +0.1 0	L_1 +0.4 0	L_2	L_3	L_4	Z° $\pm 1^\circ$
RM5-M									
M18×1.5-6g	55	≥ 13	24.5	19.8	2.4	28.5	2	26	15°

This dimension applies when tap drill cannot pass through entire boss.

Controlling design dimensions are in millimeters

Fig. 16: Notice for metric threaded flange M18×1.5-6g based on DIN ISO 6149-1

4.5 Installation and design of Temposonics® RFV

RFV-B – RFV base unit (without flange & rod assembly), example: Connection type D60 (connector outlet)

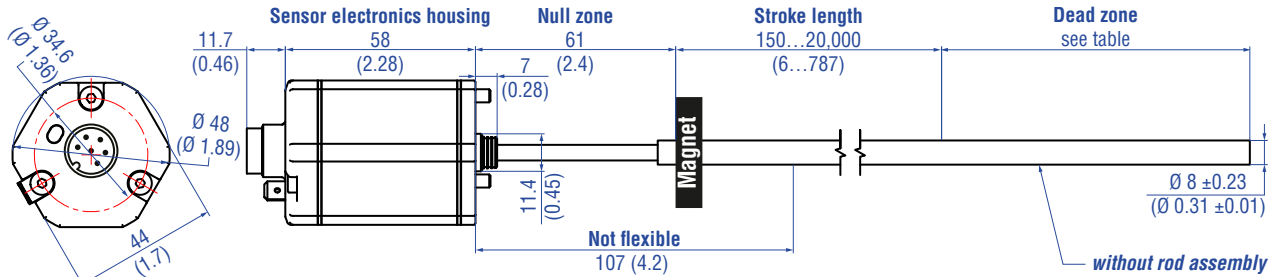

Stroke length	Tolerance of total length	Dead zone
Up to 7620 mm (300.00 in.)	+8 mm (0.31 in.)/-5 mm (0.20 in.)	94 mm (3.70 in.)
Up to 10,000 mm (393.70 in.)	+15 mm (0.59 in.)/-15 mm (0.59 in.)	100 mm (3.94 in.)
Up to 15,000 mm (590.55 in.)	+15 mm (0.59 in.)/-30 mm (1.18 in.)	120 mm (4.72 in.)
Up to 20,000 mm (787.00 in.)	+15 mm (0.59 in.)/-45 mm (1.77 in.)	140 mm (5.51 in.)

Note: Tolerance of total length has no influence on the stroke length.

RFV-M/-S – RFV with threaded flange M18×1.5-6g or 3/4"-16 UNF-3A (without rod assembly), example: Connection type D34 (connector outlet)

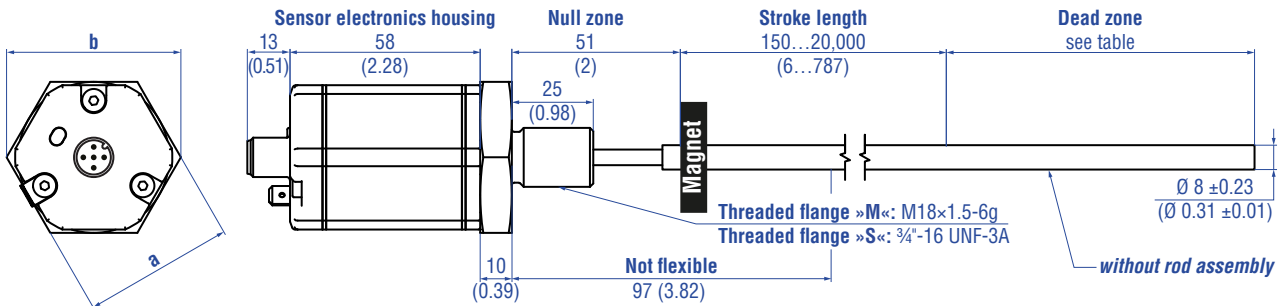

Threaded flange	a	b
>M<	A/F 46 (1.81)	53 (2.09)
>S<	A/F 44.5 (1.75)	51.3 (2.02)

Stroke length	Tolerance of total length	Dead zone
Up to 7620 mm (300.00 in.)	+8 mm (0.31 in.)/-5 mm (0.20 in.)	94 mm (3.70 in.)
Up to 10,000 mm (393.70 in.)	+15 mm (0.59 in.)/-15 mm (0.59 in.)	100 mm (3.94 in.)
Up to 15,000 mm (590.55 in.)	+15 mm (0.59 in.)/-30 mm (1.18 in.)	120 mm (4.72 in.)
Up to 20,000 mm (787.00 in.)	+15 mm (0.59 in.)/-45 mm (1.77 in.)	140 mm (5.51 in.)

Note: Tolerance of total length has no influence on the stroke length.

Controlling design dimensions are in millimeters and measurements in () are in inches

Fig. 17: Temposonics® RFV with ring magnet, part 1

RFV-B – RFV base unit (without flange & rod assembly), example: Connection type EXX/GXX/LXX/UXX (angled cable outlet)

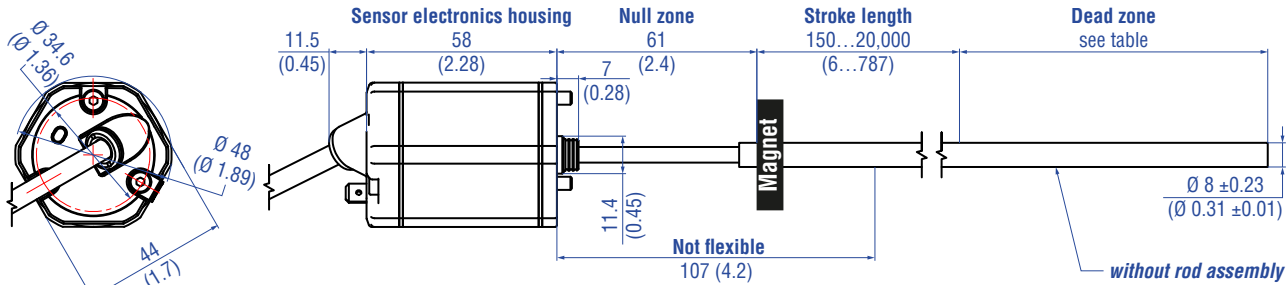

Stroke length	Tolerance of total length	Dead zone
Up to 7620 mm (300.00 in.)	+8 mm (0.31 in.)/-5 mm (0.20 in.)	94 mm (3.70 in.)
Up to 10,000 mm (393.70 in.)	+15 mm (0.59 in.)/-15 mm (0.59 in.)	100 mm (3.94 in.)
Up to 15,000 mm (590.55 in.)	+15 mm (0.59 in.)/-30 mm (1.18 in.)	120 mm (4.72 in.)
Up to 20,000 mm (787.00 in.)	+15 mm (0.59 in.)/-45 mm (1.77 in.)	140 mm (5.51 in.)

Note: Tolerance of total length has no influence on the stroke length.

RFV-B – RFV base unit (without flange & rod assembly), example: Connection type HXX/RXX/TXX (straight cable outlet)

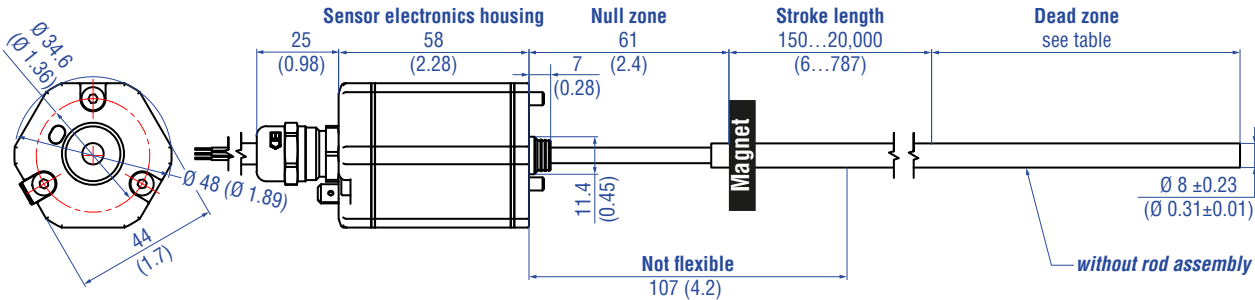

Stroke length	Tolerance of total length	Dead zone
Up to 7620 mm (300.00 in.)	+8 mm (0.31 in.)/-5 mm (0.20 in.)	94 mm (3.70 in.)
Up to 10,000 mm (393.70 in.)	+15 mm (0.59 in.)/-15 mm (0.59 in.)	100 mm (3.94 in.)
Up to 15,000 mm (590.55 in.)	+15 mm (0.59 in.)/-30 mm (1.18 in.)	120 mm (4.72 in.)
Up to 20,000 mm (787.00 in.)	+15 mm (0.59 in.)/-45 mm (1.77 in.)	140 mm (5.51 in.)

Note: Tolerance of total length has no influence on the stroke length.

Controlling design dimensions are in millimeters and measurements in () are in inches

Fig. 18: Temposonics® RFV with ring magnet, part 2

Installation of RFV

Note the following information when mounting and handling an RFV sensor:

1. Always insert the flexible sensor rod in a support tube (e.g. sensor rod HD/HL/HP or HFP profile). The support tube has to be made of non-magnetic material and has to have an inside diameter of minimum 9.4 mm (0.37 in.) (Fig. 19). The support tube can be straight or bent.
2. Do never bend beyond the minimum bending radius of 250 mm (9.84 in.).
3. Note the minimum distance to a spatial limitation of 300 mm (11.81 in.), when mounting/dismounting the sensor. The recommended distance is 500 mm (20 in.) (Fig. 20).
4. Note the non-flexible area of the sensor rod from the flange of 107 mm (4.21 in.) (for RFV-B) respectively 97 mm (3.82 in.) (for RFV-M/-S).

NOTICE
Smaller radiuses < 250 mm (9.84 in.) cause damage to the flexible sensor rod.

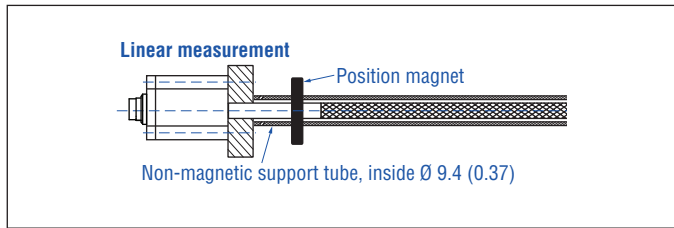

Fig. 19: Sensor with support tube

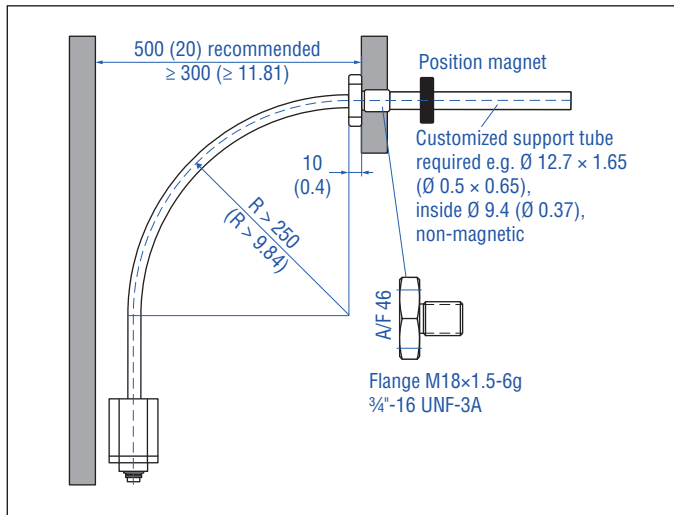

Fig. 20: Clearances for installation and handling

Controlling design dimensions are in millimeters and measurements in () are in inches

Mounting the RFV

1. RFV-B

- Insert the flexible sensor rod in a support tube.
 - Mount the sensor electronics housing by means of 3 non-magnetic socket head screws M4x59. Fastening torque: 1.4 Nm (Fig. 21). Secure the screws, e.g. using Loctite 243, before re-installing.
- Recommendation: Seal the sensor via flange.

2. RFV-B with sensor rod HD/HL/HP or HFP profile (see “Frequently ordered accessories”)

- Advantage: The flexible sensor rod is inserted in a support tube.
- Mount the sensor electronics housing by means of 3 non-magnetic socket head screws M4x59. Fastening torque: 1.4 Nm (Fig. 21). Secure the screws, e.g. using Loctite 243, before re-installing.
 - Installation details: see below

3. RFV-M/-S

- Insert the flexible sensor rod in a support tube.
- Mount the sensor via flange.
- Installation details: see below
- Please note that liquid can enter the sensor between the thread and the flexible rod.

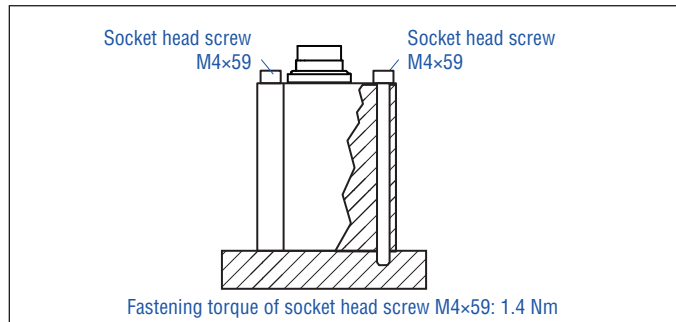

Fig. 21: Mounting with socket head screws M4x59

NOTICE
To fulfill the requirements of EMC standards for emission and immunity the following points are necessary:

- The sensor electronics housing has to be connected to machine ground (Fig. 57).
- Embed the flexible sensor element in an appropriately shielded environment, e.g. in a sensor rod HD/HL/HP.

Installation of RFV with threaded flange »M«, »S«

Fix the sensor rod via threaded flange M18×1.5-6g or ¾"-16 UNF-3A. Note the fastening torque shown in Fig. 22. Lightly oil the thread before tightening.

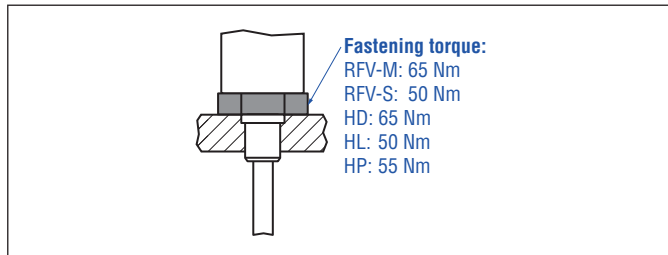

Fig. 22: Mounting example of threaded flange

Installation of an RFV sensor with sensor rod HD/HL/HP in a fluid cylinder

The rod-style version has been developed for direct stroke measurement in a fluid cylinder. Mount the sensor via threaded flange or a hex nut.

- Mounted on the face of the piston, the position magnet travels over the rod without touching it and indicates the exact position through the rod wall – independent of the hydraulic fluid.
- The pressure resistant sensor rod is installed into a bore in the piston rod.
- The base unit is mounted by means of only 3 screws. It is the only part that needs to be replaced if servicing is required, i.e. the hydraulic circuit remains closed. For more information see chapter "4.8.1 Replacement of base unit on the RH5/RFV model" on page 40.
- Seat the flange contact surface completely on the cylinder mounting surface.
- The cylinder manufacturer determines the pressure-resistant gasket (copper gasket, O-ring, etc.).
- The position magnet should not grind on the sensor rod.
- The piston rod drilling for RFV sensors with sensor rod (outer diameter 12.7 mm (0.5 in.)) is ≥ 16 mm (≥ 0.63 in.). The borehole depends on the pressure and piston speed.
- Adhere to the information relating to operating pressure.
- Protect the sensor rod against wear.

Hydraulics sealing when using an RFV sensor in a sensor rod HD/HL/HP

There are two ways to seal the flange contact surface (Fig. 23):

1. A sealing by using an O-ring (e.g. 22.4 × 2.65 mm (0.88 × 0.1 in.), 25.07 × 2.62 mm (0.99 × 0.1 in.)) in a cylinder end cap groove.
 2. A sealing by using an O-ring in the flange undercut.
- For threaded flange (¾"-16 UNF-3A) »S«: O-ring 16.4 × 2.2 mm (0.65 × 0.09 in.) (part no. 560 315)
For threaded flange (M18×1.5-6g) »M«: O-ring 15.3 × 2.2 mm (0.60 × 0.09 in.) (part no. 401 133)

In the case of threaded flange M18×1.5-6g provide a screw hole based on ISO 6149-1 (Fig. 24). See ISO 6149-1 for further information.

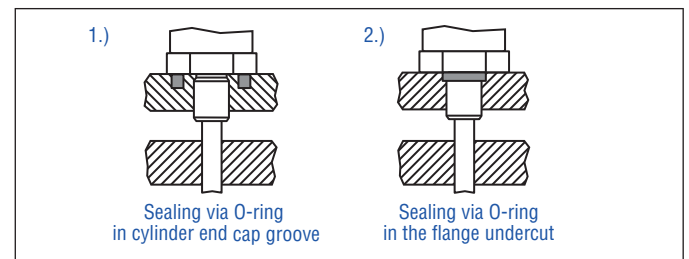

Fig. 23: Possibilities of sealing

For additional information about the accessories HFP profile and sensor rod HD/HL/HP see the accessories catalog (document part number: [551444](#)).

Notice for metric threaded flanges									
Thread (d ₁ ×P)	d ₂	d ₃	d ₄	d ₅	L ₁	L ₂	L ₃	L ₄	Z°
				+0.1 0	+0.4 0				±1°
RFV-M / optional sensor rod HD									
M18×1.5-6g	55	≥ 16	24.5	19.8	2.4	28.5	2	26	15°

Controlling design dimensions are in millimeters

Fig. 24: Notice for metric threaded flange M18×1.5-6g based on DIN ISO 6149-1

Replacing an R-Series 2004 RF-C with an R-Series V RFV-B

If you are replacing the R-Series 2004 RF-C base unit with the R-Series V RFV-B base unit, note the following points:

- The R-Series 2004 RF-C base unit is attached to the system with two screws. The R-Series V RFV-B base unit is mounted to the machine with three screws.
- Therefore, we recommend using the adapter plate kit 255198. The adapter plate is used to mount the base unit RFV-B with three screws to the existing hole pattern with two screws.
 - Fasten the adapter plate to the existing hole pattern using the two M4×6 (A/F 2.5) hexagon socket screws with a tightening torque of 1.4 Nm. Ensure that the O-ring is correctly seated between the system and the adapter plate. Secure the screws with Loctite 243.
 - Place the RFV-B base unit on the adapter plate.
 - Attach the ground lug to one screw of the base unit.
 - Screw the RFV-B base unit to the adapter plate using the three M4×59 hexagon socket screws (A/F 2.5) with a tightening torque of 1.4 Nm. Ensure that the O-ring is correctly seated between the base unit and the adapter plate. Secure the screws with Loctite 243.
- The adapter plate has a thickness of 5 mm. Order the RFV-B base unit with the addition H003 to compensate for the thickness of the adapter plate: RFV-B-xxxxxx-...-H003

4.6 Installation and design of Temposonics® RDV

RDV with bottom cable entry, example: Connection type EXX/GXX/LXX/UXX (angled cable outlet)

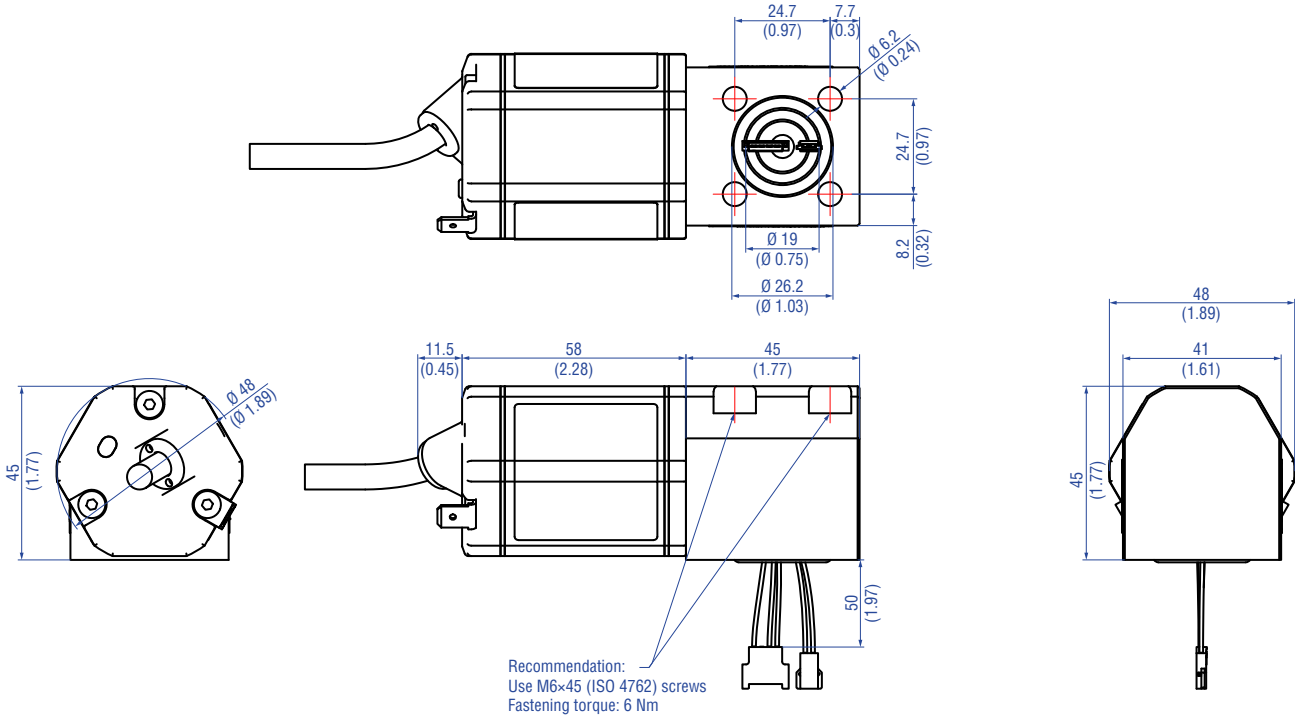

RDV with side cable entry, example: Connection type D60 (connector outlet)

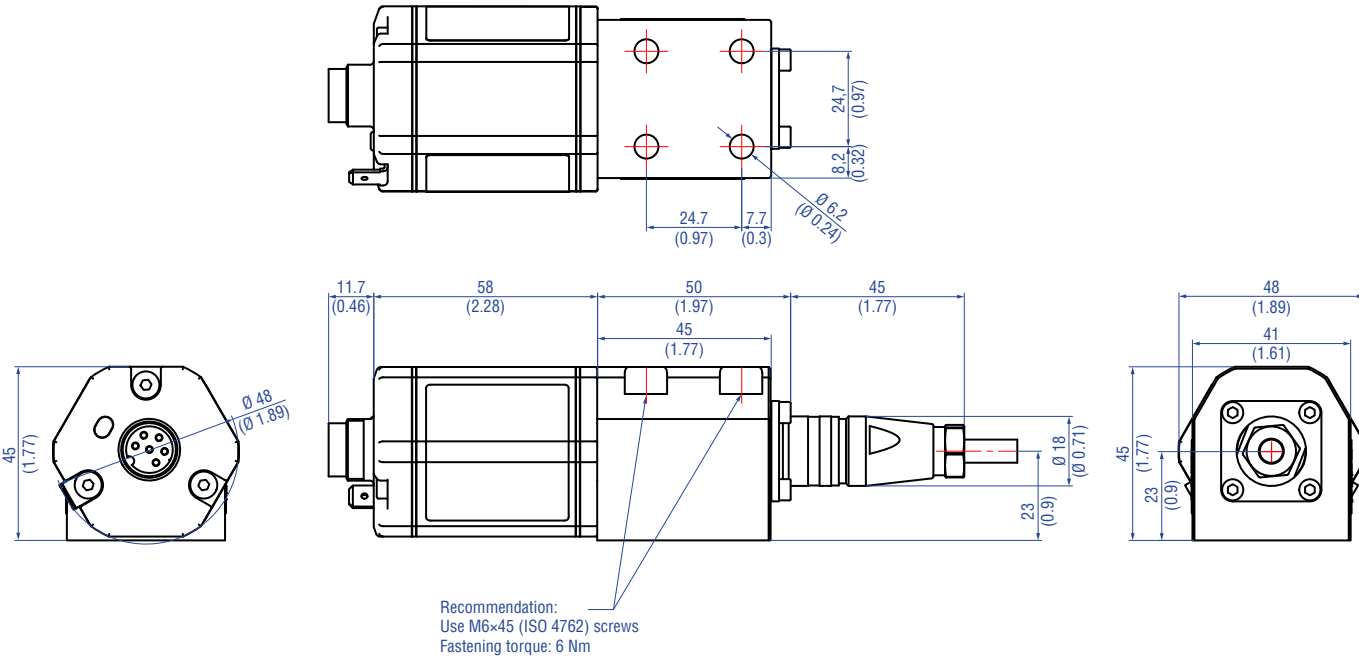

Controlling design dimensions are in millimeters and measurements in () are in inches

Fig. 25: Temposonics® RDV sensor electronics housing, part 1

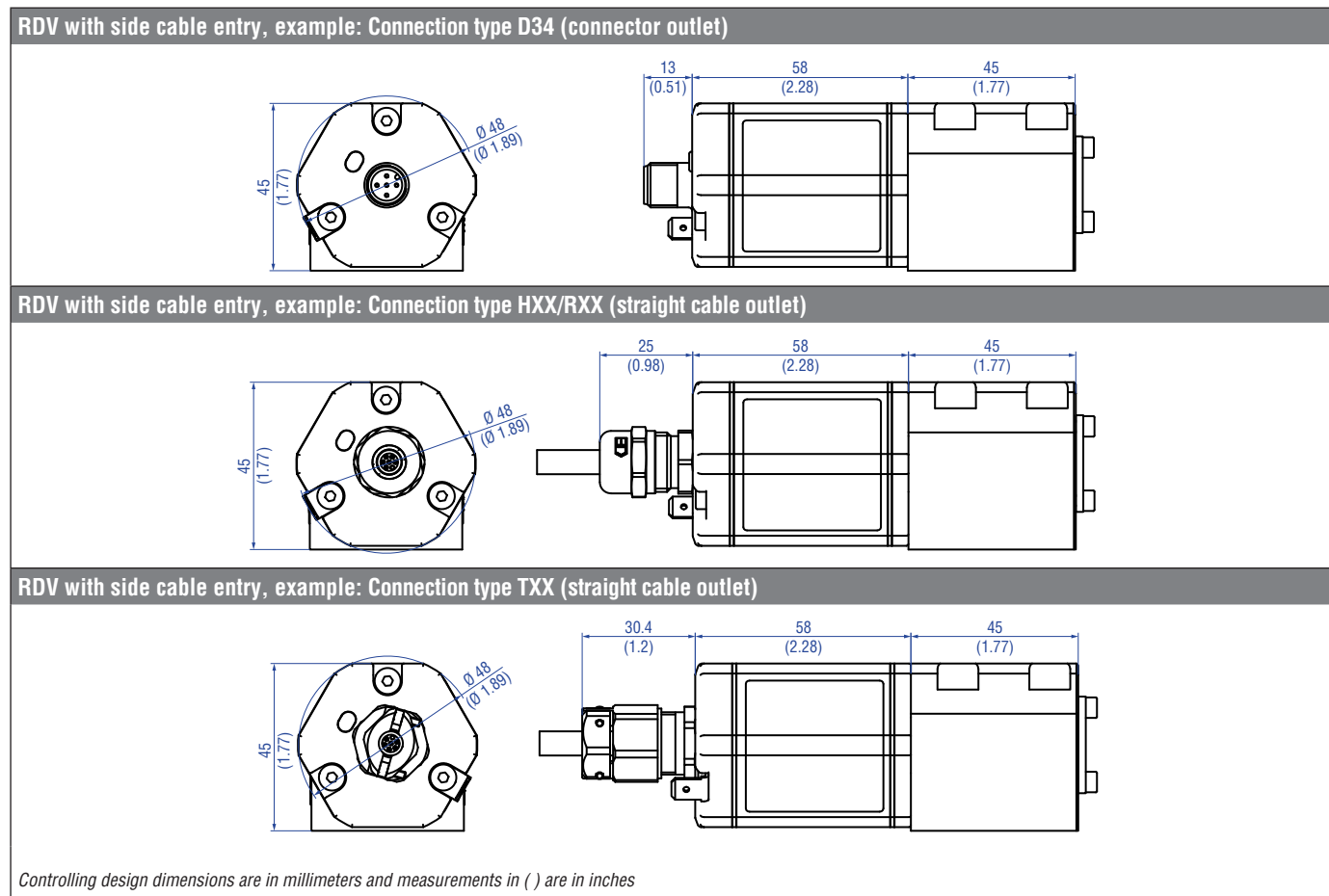

Fig. 26: Temposonics® RDV sensor electronics housing, part 2

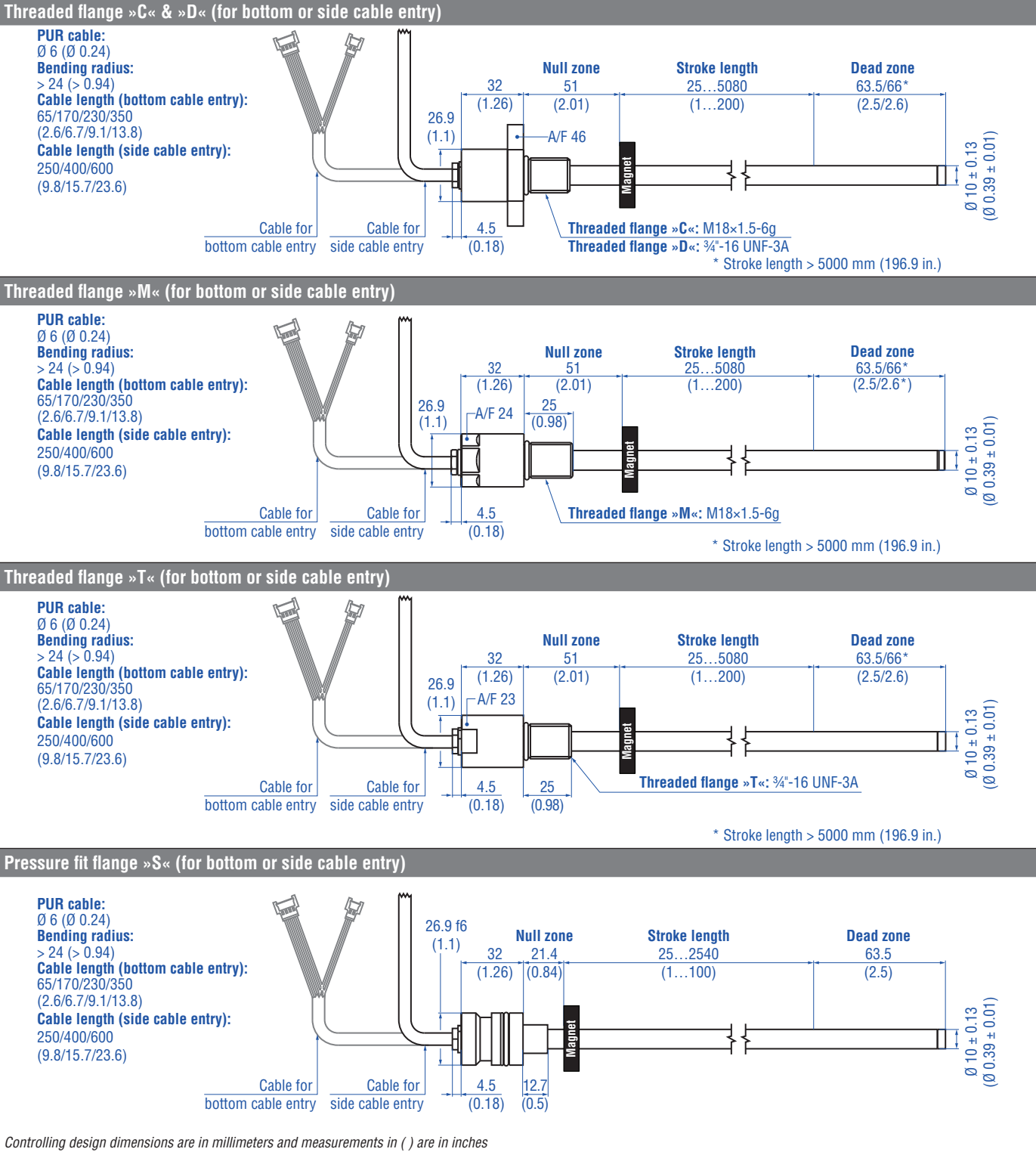
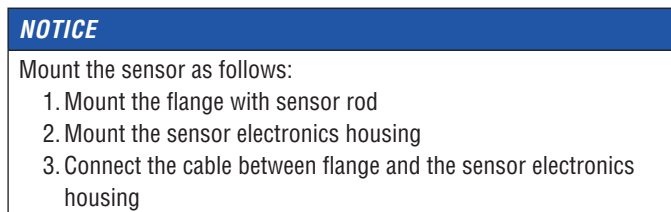
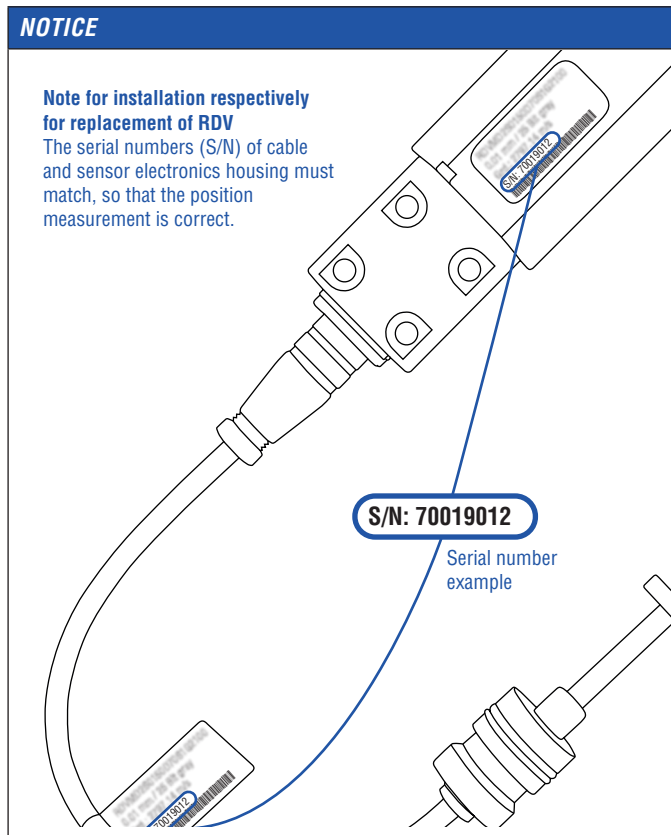

Fig. 27: Temposonics® RDV flanges



The steps mentioned above will be explained in the following sections.

4.6.1 Installation of RDV with threaded flange

Fix the sensor rod via threaded flange M18×1.5-6g or ¾"-16 UNF-3A. Note the fastening torque shown in Fig. 28. Lightly oil the thread before tightening.

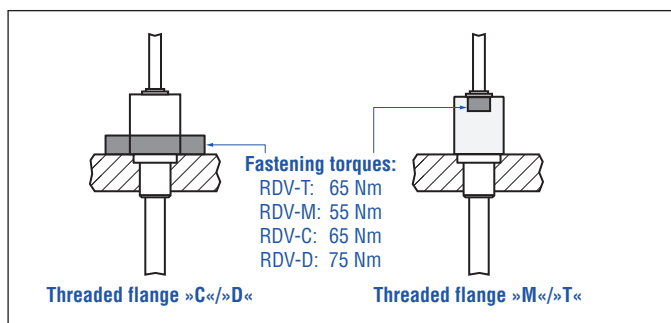

Fig. 28: Mounting example of threaded flange »C«/»D«, »M«/»T«

Controlling design dimensions are in millimeters and measurements in () are in inches

Installation of a rod-style sensor in a fluid cylinder

The rod-style version has been developed for direct stroke measurement in a fluid cylinder. Mount the sensor via threaded flange or a hex nut.

- Mounted on the face of the piston, the position magnet travels over the rod without touching it and indicates the exact position through the rod wall – independent of the hydraulic fluid.
- The pressure resistant sensor rod is installed into a bore in the piston rod.

Hydraulics sealing

There are two ways to seal the flange contact surface (Fig. 29):

1. Sealing via an O-ring (e.g. 22.4 × 2.65 mm, 25.07 × 2.62 mm) in a cylinder end cap groove (for threaded flange »C«/»D«)
2. Sealing via an O-ring 16.4 × 2.2 mm (part no. 560 315) in the flange undercut.

For threaded flange (¾"-16 UNF-3A) »D«/»T«:

O-ring 16.4 × 2.2 mm (0.65 × 0.09 in.) (part no. 560 315)

For threaded flange (M18×1.5-6g) »C«/»M«:

O-ring 15.3 × 2.2 mm (0.60 × 0.09 in.) (part no. 401 133)

In the case of threaded flange M18×1.5-6g provide a screw hole based on ISO 6149-1 (Fig. 30). See ISO 6149-1 for further information.

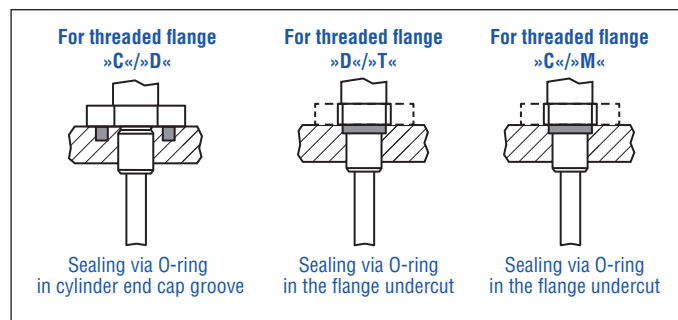

Fig. 29: Possibilities of sealing

- Seat the flange contact surface completely on the cylinder mounting surface.
- The cylinder manufacturer determines the pressure-resistant gasket (copper gasket, O-ring, etc.).
- The position magnet should not grind on the sensor rod.
- The piston rod drilling ($\geq \varnothing 13 \text{ mm}$ ($\geq \varnothing 0.51 \text{ in.}$)) depends on the pressure and piston speed.
- Adhere to the information relating to operating pressure.
- Protect the sensor rod against wear.

Notice for metric threaded flanges									
Thread ($d_1 \times P$)	d_2	d_3	d_4	d_5	L_1	L_2	L_3	L_4	Z°
				+0.1 0	+0.4 0				$\pm 1^\circ$
RDV-C									
M18×1.5-6g	55	≥ 13	24.5	19.8	2.4	28.5	2	26	15°
RDV-M									
M18×1.5-6g	30	≥ 13	24.5	19.8	2.4	28.5	2	26	15°

Fig. 30: Notice for metric threaded flange M18×1.5-6g based on DIN ISO 6149-1

4.6.2 Installation of RDV with pressure fit flange

Cylinder mounting

Install the rod using the pressure fit flange. Seal it off by means of the O-ring and the back-up ring. Block the pressure fit flange using a shoulder screw (Fig. 31). For details of the pressure fit flange »S« see Fig. 32. Also note the mounting examples in Fig. 33 and Fig. 34.

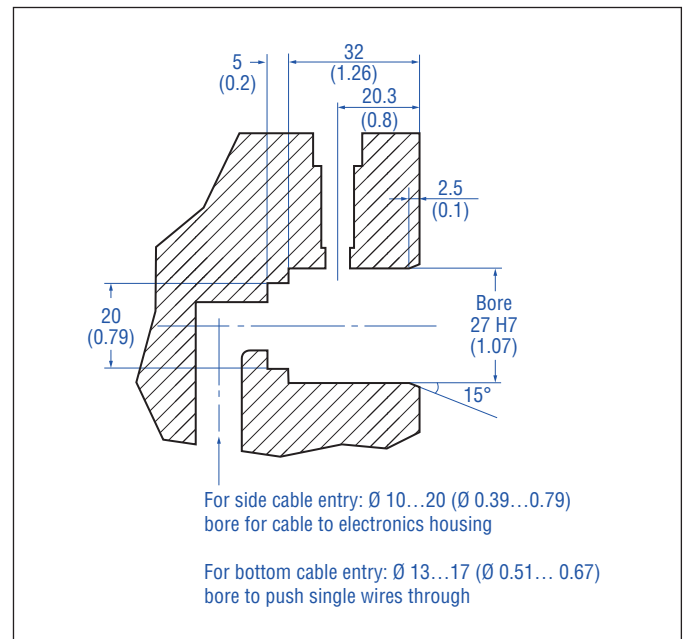

Fig. 31: Example of mounting detail: Shoulder screw 8-M6 (ISO 7379) with internal hexagon

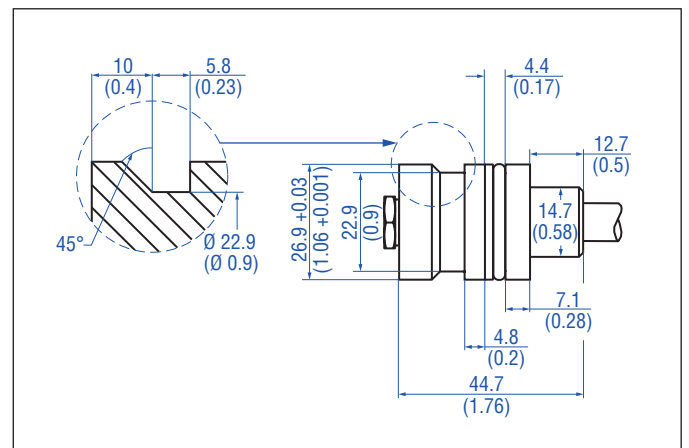

Fig. 32: Pressure fit flange »S« details

Note for cylinder installation:

- The position magnet should not grind on the sensor rod.
- The piston rod drilling ($\geq \text{Ø } 13 \text{ mm}$ ($\geq \text{Ø } 0.51 \text{ in.}$)) depends on the pressure and piston speed.
- Adhere to the information relating to operating pressure.
- Protect the sensor rod against wear.

Controlling design dimensions are in millimeters and measurements in () are in inches

4.6.3 Installation of RDV's sensor electronics housing

The following section explains the connection of an RDV sensor with bottom cable entry (Fig. 33) and side cable entry (Fig. 34) based on RDV-S. The sensor electronics of RDV sensors with threaded flange are mounted in the same way.

Sensor electronics with bottom cable entry

Connect the rod via the connector to the sensor electronics. Mount the sensor electronics so that you can lead the cables below the bottom of the housing. Thus the sensor system including the connection cables is fully encapsulated and protected against external disturbances (Fig. 33). Note the bending radius of the cable if you run the cable between sensor electronics and rod (see Fig. 27).

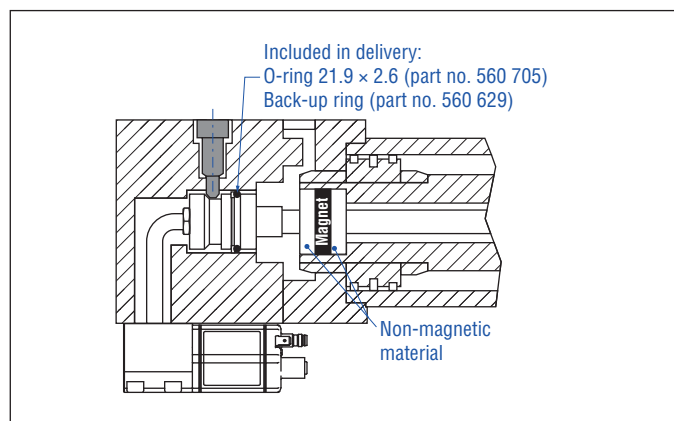

Fig. 33: Mounting example of pressure fit flange »S« and sensor electronics with bottom cable entry

Sensor electronics with side cable entry

Connect the rod via the cable to the sensor electronics on the side. Encapsulate the sensor system including the connection cables (Fig. 34). Note the bending radius of the cable if you run the cable between sensor electronics and rod (see Fig. 27).

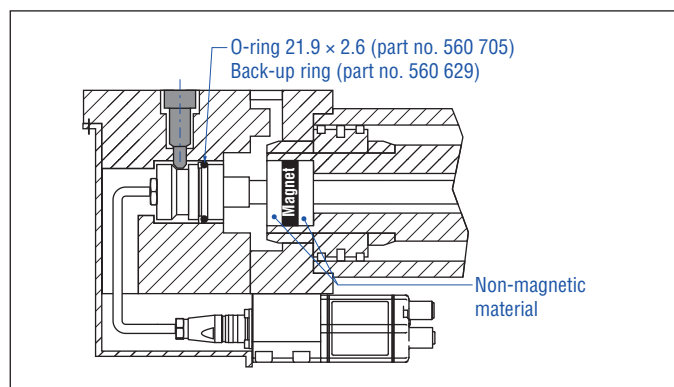

Fig. 34: Mounting example of pressure fit flange »S« and sensor electronics with side cable entry

NOTICE

To fulfill the requirements of EMC standards for emission and immunity the following points are necessary:

- The sensor electronics housing has to be connected to machine ground (Fig. 57).
- The cable between the sensor and the electronics must be integrated into a metallic housing.

Connect the flange to the sensor electronics housing via the molex connectors for bottom cable entry respectively via the 6 pin cable for side cable entry.

4.6.4 Mounting of sensor electronics housing

Mount the sensor electronics housing with 4 × M6×45 (ISO 4762) screws via the mounting block. Note the fastening torque of 6 Nm.

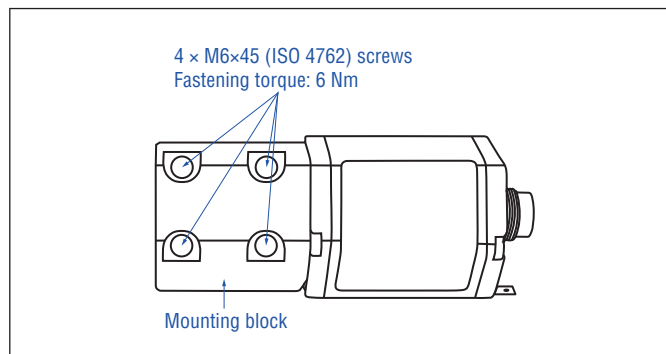

Fig. 35: Mounting of RDV's sensor electronics housing (example of bottom cable entry)

4.7 Magnet installation

Typical use of magnets





Magnet	Typical sensors	Benefits
	Ring magnets Rod model (RH5, RM5, RFV, RDV)	<ul style="list-style-type: none"> Rotationally symmetrical magnetic field
	U-magnets Profile & rod models (RP5, RH5, RM5, RFV, RDV)	<ul style="list-style-type: none"> Height tolerances can be compensated, because the magnet can be lifted off
	Block magnets Profile & rod models (RP5, RH5, RM5, RFV, RDV)	<ul style="list-style-type: none"> Height tolerances can be compensated, because the magnet can be lifted off
	Magnet sliders Profile models (RP5)	<ul style="list-style-type: none"> The magnet is guided by the profile The distance between the magnet and the waveguide is strictly defined Easy coupling via the ball joint

Fig. 36: Typical use of magnets

Mounting ring magnets, U-magnets & block magnets

Install the magnet using non-magnetic material for mounting device, screws, spacers etc.. The magnet must not grind on the sensor rod/profile. Alignment errors are compensated via the air gap.

- Permissible surface pressure: Max. 40 N/mm² (only for ring magnets and U-magnets)
- Fastening torque for M4 screws: 1 Nm; use washers, if necessary
- Minimum distance between position magnet and any magnetic material has to be 15 mm (0.6 in.) (Fig. 39).
- If no other option exists and magnetic material is used, observe the specified dimensions (Fig. 39).

NOTICE

- Mount ring magnets and U-magnets concentrically.
- Mount block magnets centrically over the sensor rod or the sensor profile. The maximum permissible air gap must not be exceeded (Fig. 37/Fig. 38).
- Take care to mount the primary sensor axis in parallel to the magnet path in order to avoid damage to the carriage, magnet and sensor rod/profile.

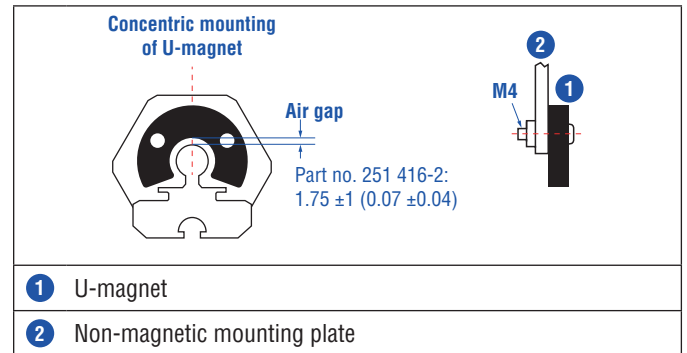

Fig. 37: Mounting of U-magnet (part no. 251 416-2)

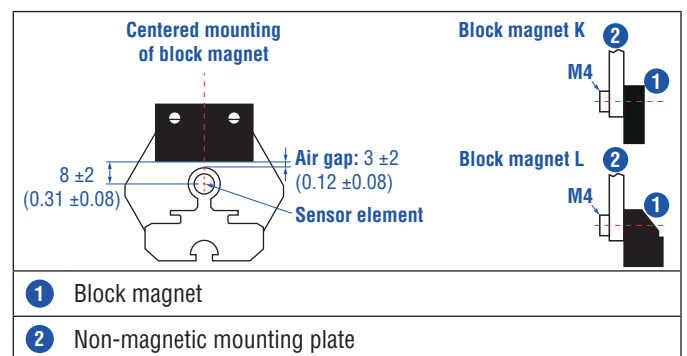

Fig. 38: Mounting of block magnet K (part no. 251 298-2) and block magnet L (part no. 403 448)

Magnet mounting with magnetic material

When using magnetic material the dimensions of Fig. 39 must be observed.

- If the position magnet aligns with the drilled piston rod
- If the position magnet is set further into the drilled piston rod, install another non-magnetic spacer (e.g. part no. 400 633) above the magnet.

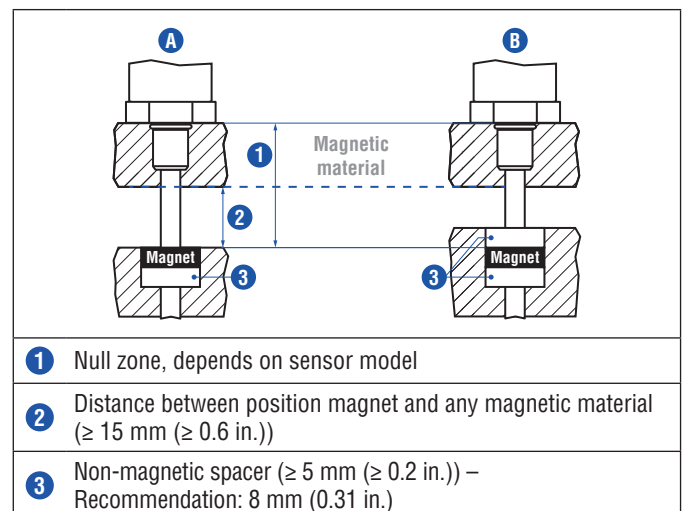

Fig. 39: Installation with magnetic material

Controlling design dimensions are in millimeters and measurements in () are in inches

Rod sensors with stroke lengths \geq 1 meter (3.3 ft.)

Support horizontally installed sensors with a stroke length of 1 meter (3.3 ft.) and more mechanically at the rod end. Without using a support, the sensor rod bends over and the rod and the position magnet may be damaged. A false measurement result is also possible. Longer rod require evenly distributed mechanical support over the entire length (e.g. part no. 561 481). Use an U-magnet (Fig. 40) for measurement.

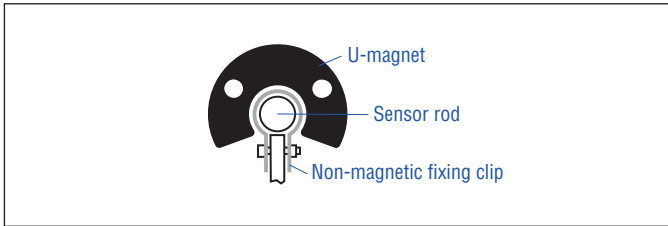

Fig. 40: Example of sensor support (part no. 561 481)

Start- and end positions of the position magnets

Consider the start and end positions of the position magnets during the installation. To ensure that the entire stroke length is electrically usable, the position magnet must be mechanically mounted as follows.

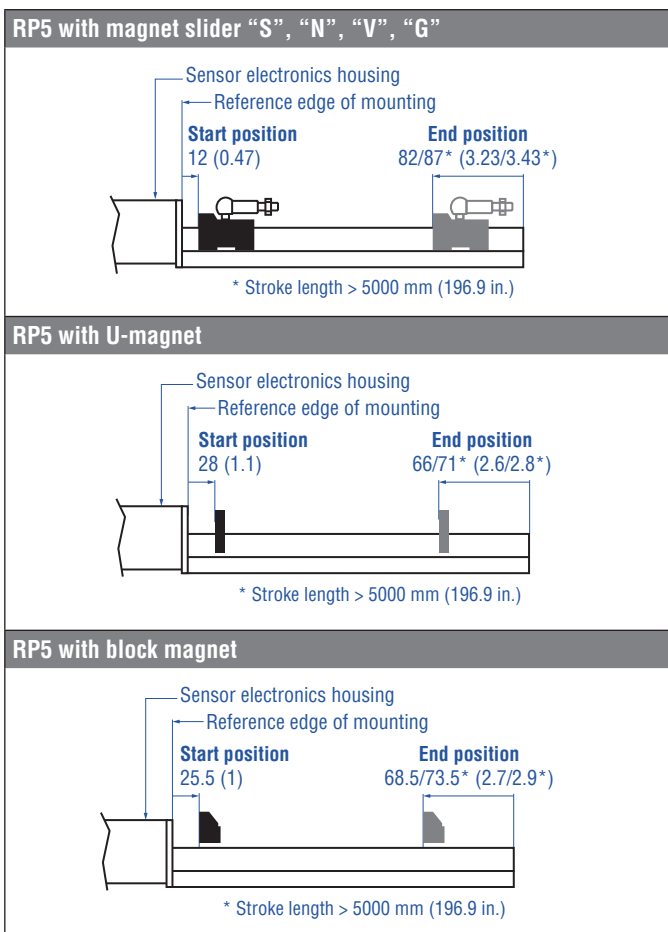

Fig. 41: Start- and end positions of magnets for RP5

Controlling design dimensions are in millimeters and measurements in () are in inches

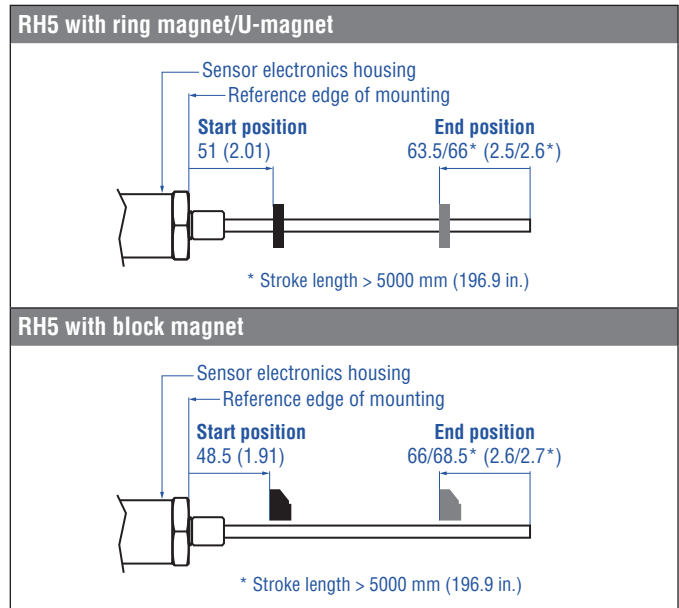

Fig. 42: Start- and end positions of magnets for RH5

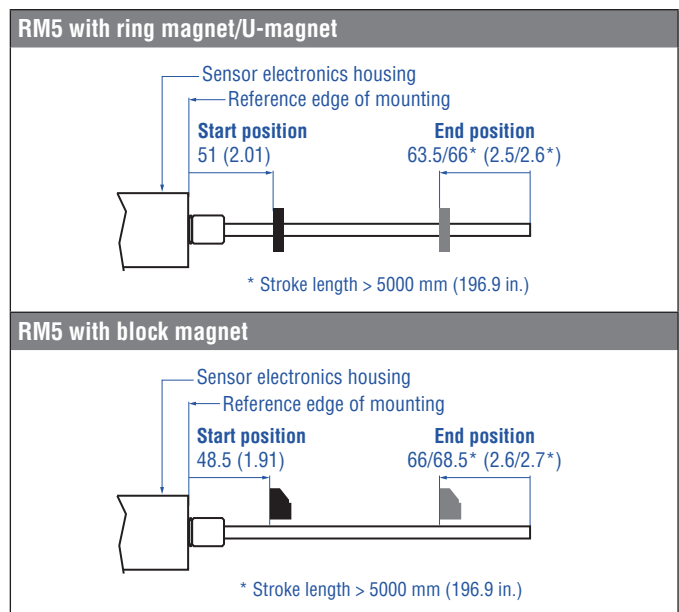

Fig. 43: Start- and end positions of magnets for RM5

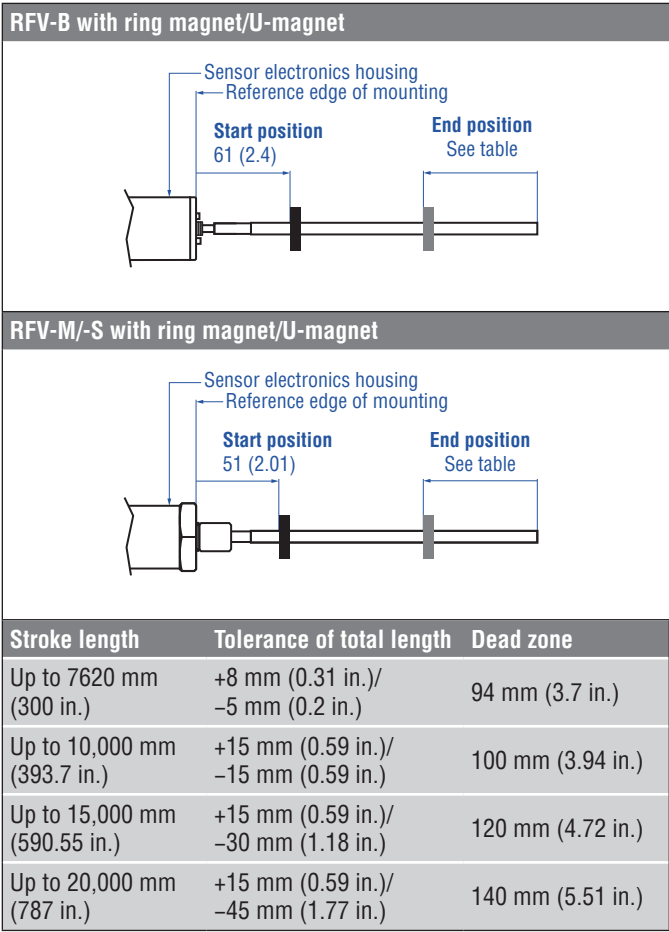

Fig. 44: Start- and end positions of magnets for RFV with ring- and U-magnets

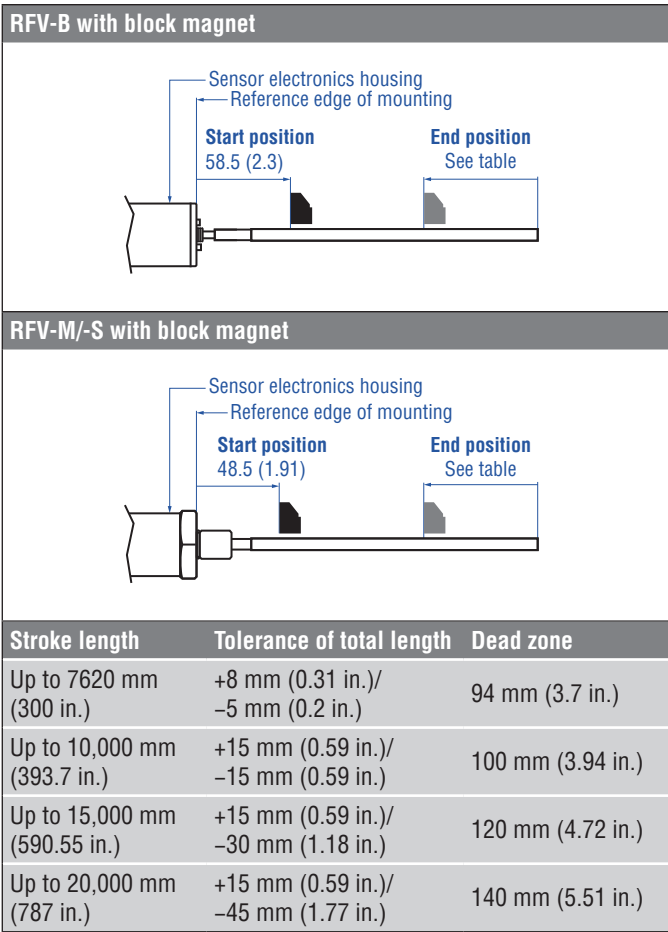

Fig. 45: Start- and end positions of magnets for RFV with block magnet

Controlling design dimensions are in millimeters and measurements in () are in inches

NOTICE

On all sensors, the areas left and right of the active stroke length are provided for null and dead zone. These zones should not be used for measurement, however the active stroke length can be exceeded.

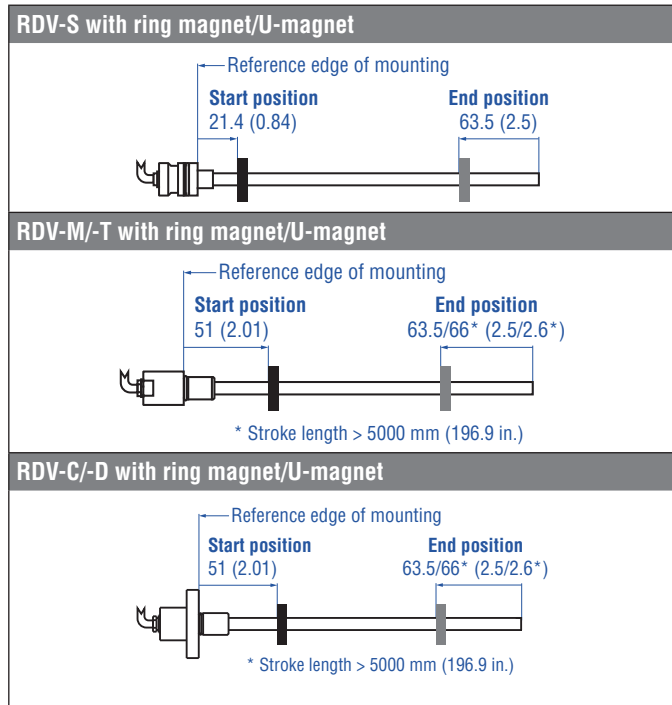

Fig. 46: Start- and end positions of magnets for RDV with ring- and U-magnets

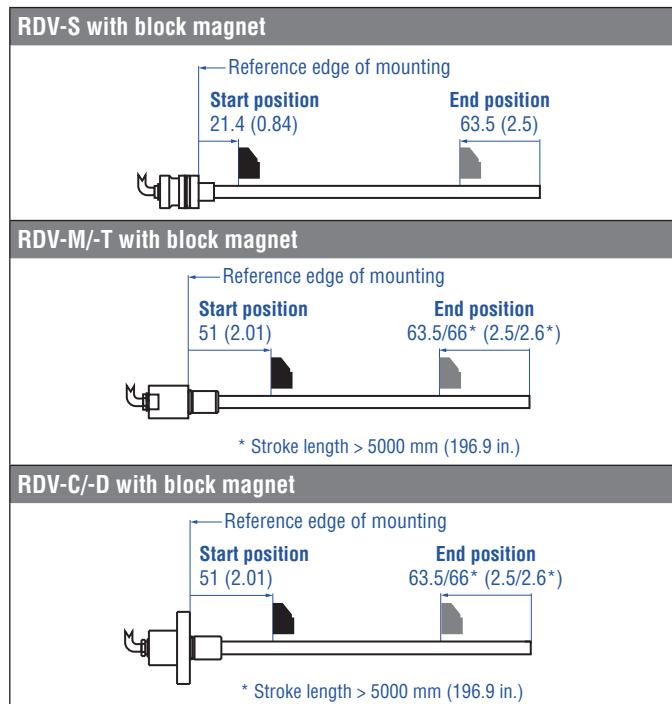

Fig. 47: Start- and end positions of magnets for RDV with block magnet

Differential/multi-position measurement

For a differential or multi-position measurement two positions are measured on the sensor rod or sensor profile. The distance between these positions will be output.

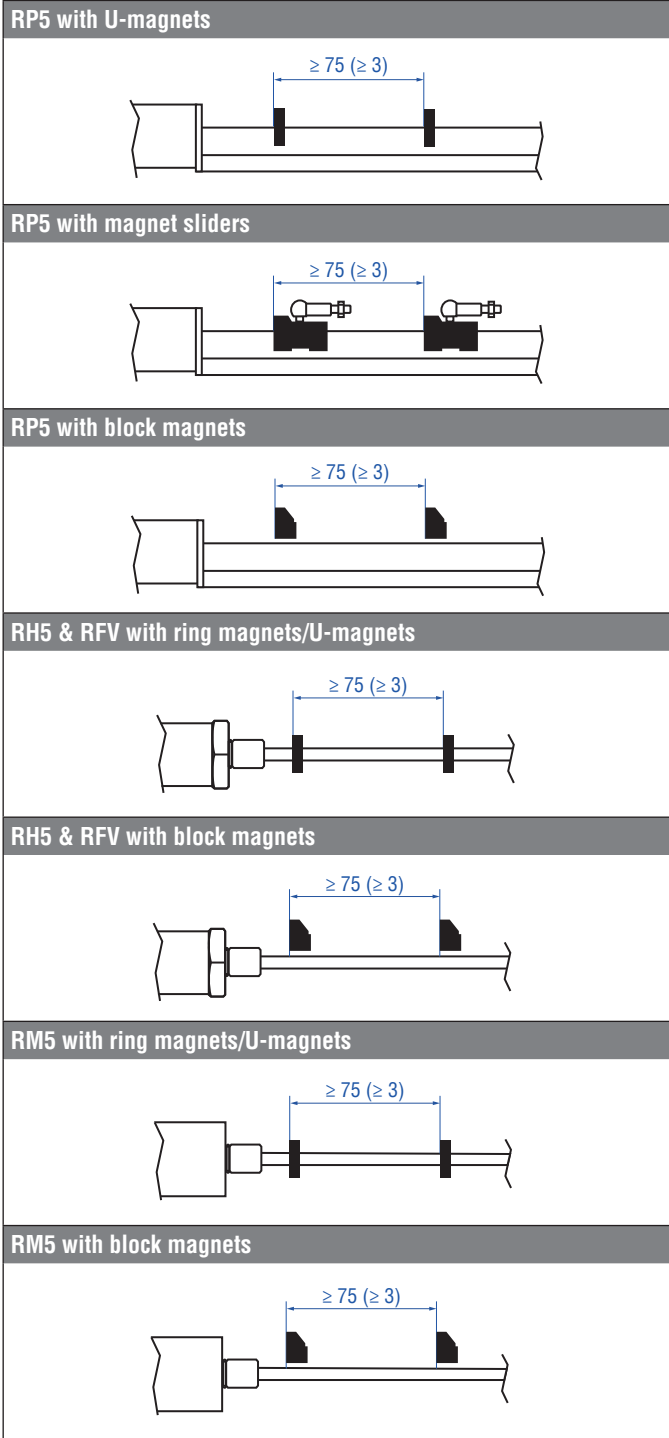

Fig. 48: Minimum distance between magnets for differential/multi-position measurement (RP5, RH5, RFV, RM5)

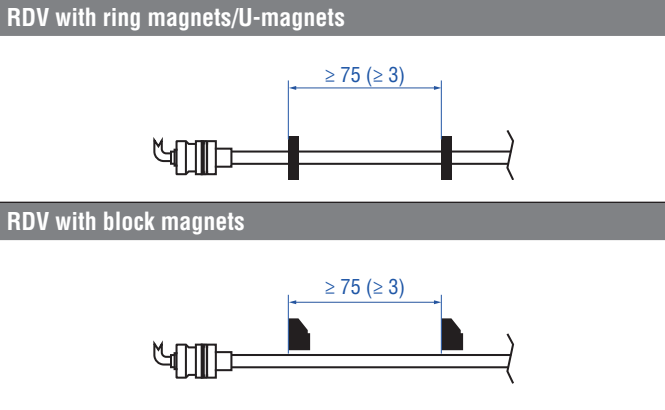

Fig. 49: Minimum distance between magnets for differential/multi-position measurement (RDV)

NOTICE
Use magnets of the same type for differential or multi-position measurement. Do not go below a minimal distance of 75 mm (3 in.) between the magnets for differential or multi-position measurement. Contact Temposonics if you need a magnet distance, which is smaller than 75 mm (3 in.).

Controlling design dimensions are in millimeters and measurements in () are in inches

4.8 Replacement of base unit

4.8.1 Replacement of base unit on the RH5/RFV model

The base unit of the sensor model RH5 (RH5-B) is replaceable as shown in Fig. 50 and Fig. 51 for the sensor designs »M«, »S« and »T«. The sensor can be replaced without interrupting the hydraulic circuit. This also applies to the RFV-B sensor, which is installed in the optional HD, HL and HP sensor rod.

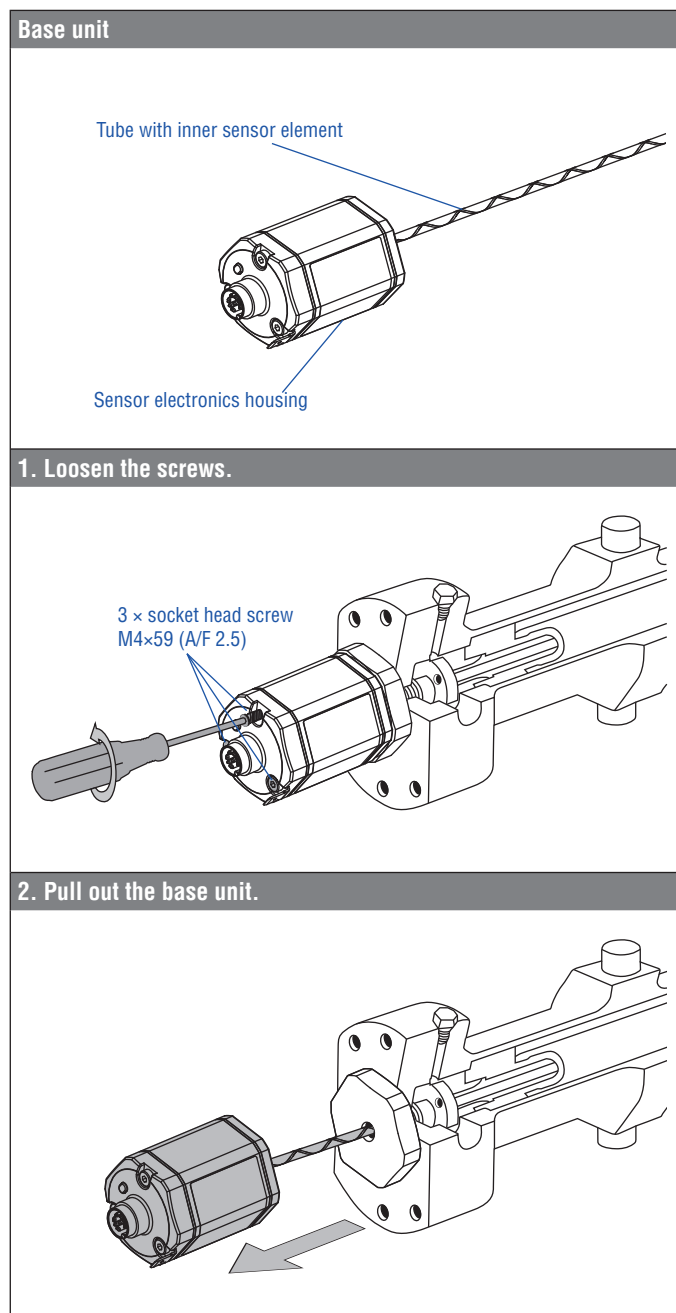

Fig. 50: Replacement of the base unit (e.g. RH5 sensor), part 1

3. Insert the new base unit.
Install the ground lug on a screw.
Tighten the screws.

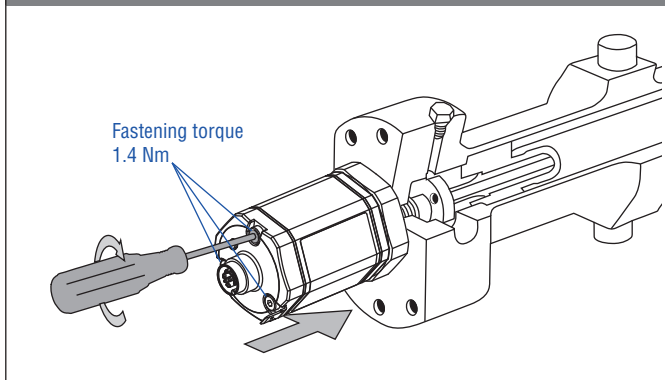

Fig. 51: Replacement of the base unit (e.g. RH5 sensor), part 2

NOTICE

- When replacing the base unit, make sure that no humidity enters the sensor tube. This may damage the sensor.
- Secure the base unit screws, e.g. using Loctite 243, before re-installing.
- If the R-Series V replaces a predecessor model of the R-Series, the plastic tube in the sensor rod must be removed.
- Make sure the O-ring is correctly fitted between the flange and the base unit.

4.8.2 Replacement of base unit on the RM5 model

A base unit RM5-B is installed in the super shield housing of the RM5 (Fig. 52). The base unit can be replaced without interrupting the hydraulic circuit.

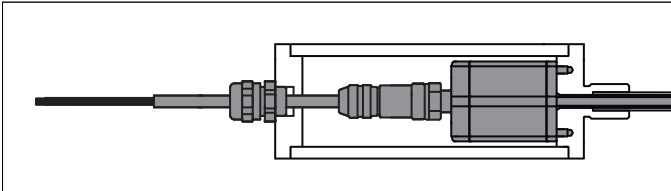

Fig. 52: Base unit in the super shield housing of the RM5

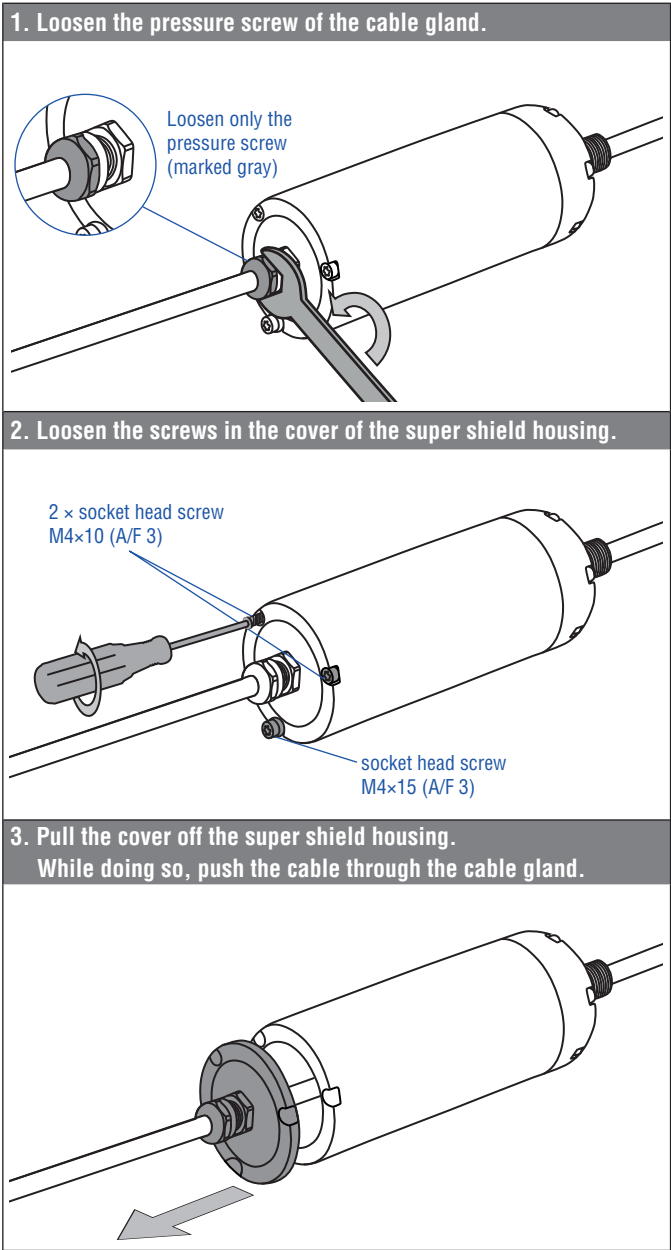

Fig. 53: Replacement of the base unit on model RM5, part 1

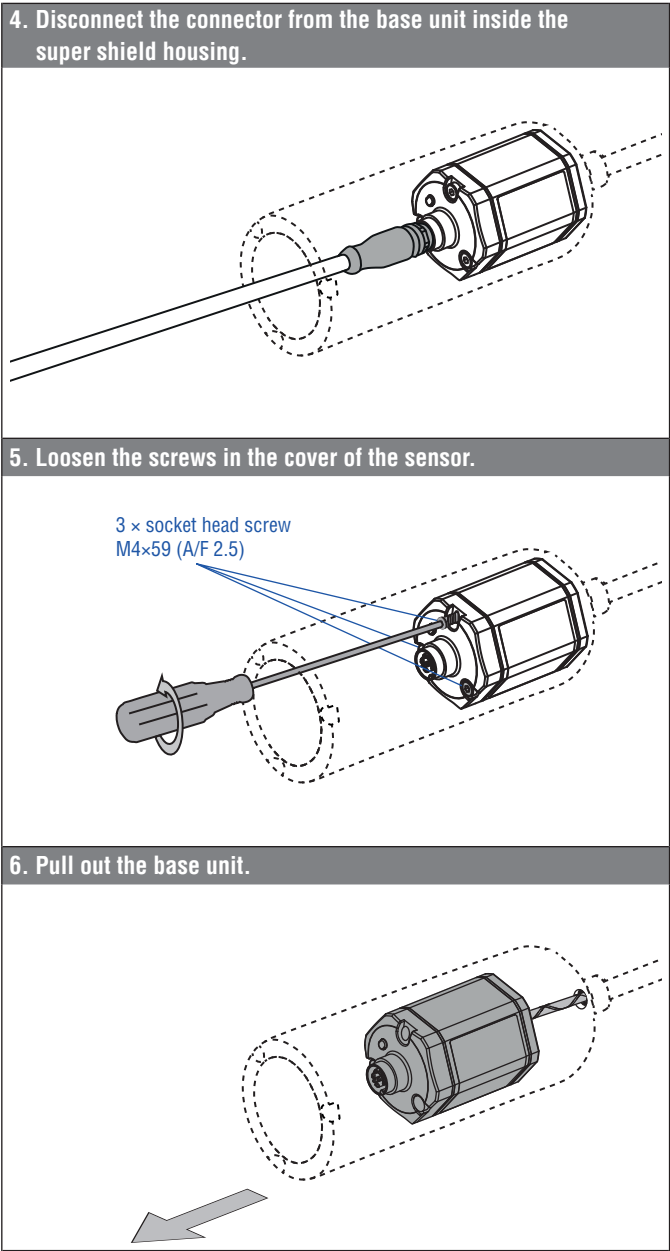
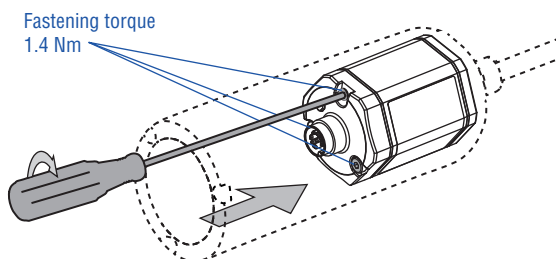

Fig. 54: Replacement of the base unit on model RM5, part 2

Continued on next page

7. Insert the new base unit.
Screw the base unit tight.
Secure the screws of the base unit before re-installing,
e.g. with Loctite 243.



8. Attach the connector to the base unit in the super shield housing.

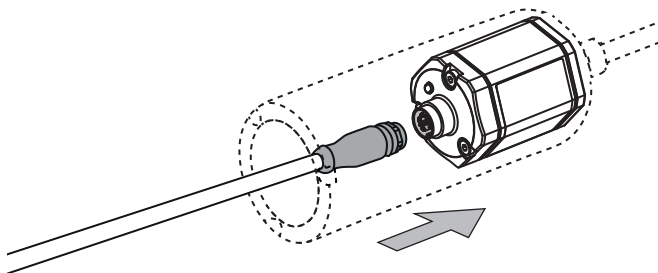

9. Place the lid on the super shield housing.
Screw the lid tight.
Secure the screws of the lid before reassembly,
e.g. with Loctite 243.

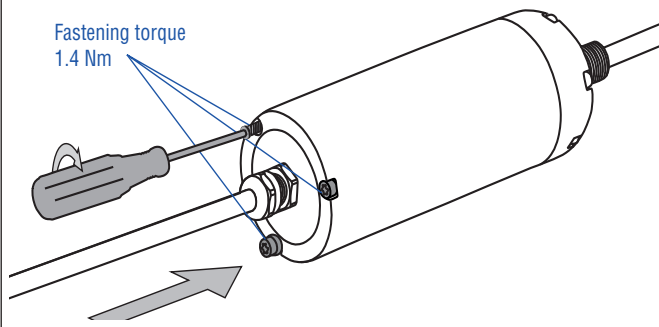

Fig. 55: Replacement of the base unit on model RM5, part 3

10. Carefully pull the excess cable out of the super shield housing. Tighten the pressure screw (marked gray) of the cable gland until the sealing insert and pressure screw are at the same height.
Secure the cable gland before reassembly, e.g. with Loctite 243.

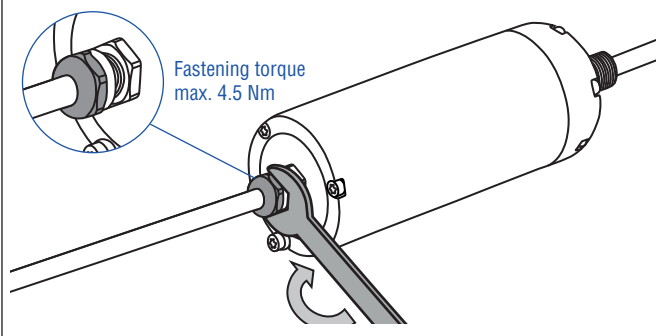

Fig. 56: Replacement of the base unit on model RM5, part 4

NOTICE

When replacing the base unit, make sure that no humidity enters the sensor tube. This may damage the sensor.

4.9 Electrical connection

Placement of installation and cabling have decisive influence on the sensor's electromagnetic compatibility (EMC). Hence correct installation of this active electronic system and the EMC of the entire system must be ensured by using suitable metal connectors, shielded cables and grounding. Overvoltages or faulty connections can damage its electronics despite protection against wrong polarity.

NOTICE

1. Do not mount the sensors in the area of strong magnetic or electric noise fields.
2. Never connect/disconnect the sensor when voltage is applied.

Instructions for connection

- Use low-resistant twisted pair and shielded cables. Connect the shield to ground externally via the control system equipment.
- Keep control and signal cables separate from power cables and sufficiently far away from motor cables, frequency inverters, valve lines, relays, etc..
- Use only connectors with metal housing and connect the shielding to the connector housing.
- Keep the connection surface at both shielding ends as large as possible. Connect the cable clamps to function as a ground.
- Keep all non-shielded leads as short as possible.
- Keep the earth connection as short as possible with a large cross section. Avoid ground loops.
- With potential differences between machine and electronics earth connections, no compensating currents are allowed to flow across the cable shielding.

Recommendation:

Install potential compensating leads with large cross section, or use cables with separate double shielding, and connect only one end of the shield.

- Use only stabilized power supplies in compliance with the specified electrical ratings.

Grounding of profile and rod sensors

Connect the sensor electronics housing to machine ground. Ground R-Series V via ground lug as shown in Fig. 57. Note the installation example for grounding an RM5 sensor in Fig. 58. In addition you can ground the sensor models RH5, RM5 and RFV via thread.

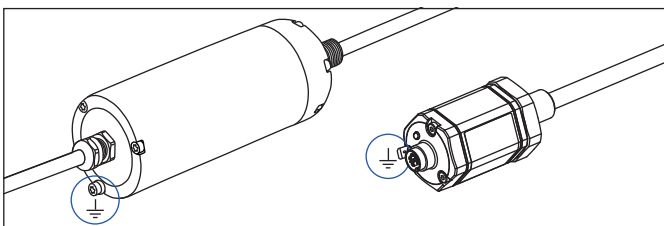

Fig. 57: Grounding via ground lug on the example of an RM5 sensor (left) / RH5 sensor (right)

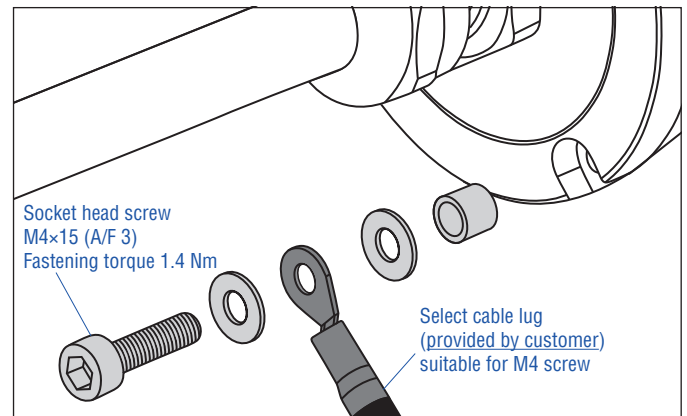

Fig. 58: Installation example for grounding of RM5 sensor

NOTICE

Secure the socket head screw before reassembly, e.g. with Loctite 243.

Connector wiring

Connect the sensor directly to the control system, indicator or other evaluating systems as follows:

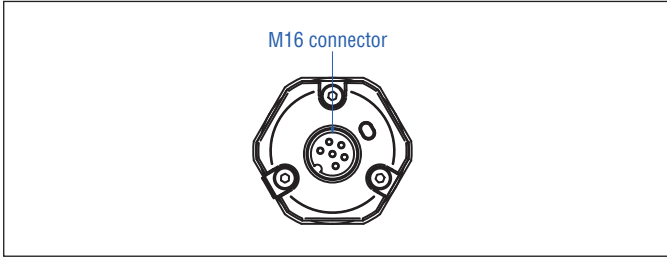

Fig. 59: Location of connection (example M16 connector outlet)

D34			
Signal + power supply			
M12 male connector	Output	Pin	Function
<p>View on sensor</p>	1	1	+12...30 VDC (±20 %)
		2	Position (magnet 1)
	2*	3	DC Ground (0 V)
		4	Position (magnet 2) or reverse position (magnet 1) or speed or velocity (magnet 1) or temperature inside the sensor electronics housing
		5	Signal Ground
* order dependent			

Fig. 60: Connector wiring D34

D60			
Signal + power supply			
M16 male connector	Output	Pin	Function
<p>View on sensor</p>	1	1	Position (magnet 1)
		2	Signal Ground
	2*	3	Position (magnet 2) or reverse position (magnet 1) or speed or velocity (magnet 1) or temperature inside the sensor electronics housing
		4	Signal Ground
		5	+12...30 VDC (±20 %)
	6	DC Ground (0 V)	
* order dependent			

Fig. 61: Connector wiring D60

HXX or LXX / RXX or EXX / TXX or GXX / UXX			
Signal + power supply			
Cable	Output	Color	Function
1		GY	Position (magnet 1)
		PK	Signal Ground
2*		YE	Position (magnet 2) or reverse position (magnet 1) or speed or velocity (magnet 1) or temperature inside the sensor electronics housing
		GN	Signal Ground
		BN	+12...30 VDC (±20 %)
	WH	DC Ground (0 V)	
			* order dependent
For cable type TXX, the extra red & blue wires are not used.			

Fig. 62: Connector wiring cable outlet

NOTICE

For sensors with current output (order code section **h** Output **A** Current), the output 1 (position (magnet 1)) must be connected in any case.

Straight cable outlet			Cable type	Angled cable outlet
H	X	X	Part no. 530 052 PUR →	L X X Part no. 530 052
R	X	X	Part no. 530 032 PVC →	E X X Part no. 530 032
T	X	X	Part no. 530 112 FEP →	G X X Part no. 530 157

Fig. 63: Cable types assignment

4.10 Frequently ordered accessories for Temposonics® RP5 – Additional options available in our [Accessories Catalog](#) 551 444

Position magnets

<p>Magnet slider S, joint at top Part no. 252 182</p> <p>Material: GRP, magnet hard ferrite Weight: Approx. 35 g Operating temperature: -40...+85 °C (-40...+185 °F)</p>	<p>Magnet slider V, joint at front Part no. 252 184</p> <p>Material: GRP, magnet hard ferrite Weight: Approx. 35 g Operating temperature: -40...+85 °C (-40...+185 °F)</p>	<p>Magnet slider N longer ball-joint arm Part no. 252 183</p> <p>Material: GRP, magnet hard ferrite Weight: Approx. 35 g Operating temperature: -40...+85 °C (-40...+185 °F)</p>	<p>Magnet slider G, backlash free Part no. 253 421</p> <p>Material: GRP, magnet hard ferrite Weight: Approx. 25 g Operating temperature: -40...+85 °C (-40...+185 °F)</p>

Position magnets

Mounting accessories

<p>U-magnet OD33 Part no. 251 416-2</p> <p>Material: PA ferrite GF20 Weight: Approx. 11 g Surface pressure: Max. 40 N/mm² Fastening torque for M4 screws: 1 Nm Operating temperature: -40...+105 °C (-40...+221 °F)</p> <p>Marked version for sensors with internal linearization: Part no. 254 226</p>	<p>Block magnet L Part no. 403 448</p> <p>Material: Plastic carrier with hard ferrite magnet Weight: Approx. 20 g Fastening torque for M4 screws: 1 Nm Operating temperature: -40...+75 °C (-40...+167 °F)</p> <p>This magnet may influence the sensor performance specifications for some applications.</p>	<p>Mounting clamp Part no. 400 802</p> <p>Material: Stainless steel (AISI 304)</p>	<p>T-nut Part no. 401 602</p> <p>Fastening torque for M5 screw: 4.5 Nm</p>

4.11 Frequently ordered accessories for Tempsonics® RH5 – Additional options available in our [Accessories Catalog](#) 551444

Position magnets

<p>U-magnet OD33 Part no. 251 416-2</p>	<p>Ring magnet OD33 Part no. 201 542-2</p>	<p>Ring magnet OD25.4 Part no. 400 533</p>	<p>Ring magnet Part no. 402 316</p>
<p>Material: PA ferrite GF20 Weight: Approx. 11 g Surface pressure: Max. 40 N/mm² Fastening torque for M4 screws: 1 Nm Operating temperature: -40...+105 °C (-40...+221 °F)</p>	<p>Material: PA ferrite GF20 Weight: Approx. 14 g Surface pressure: Max. 40 N/mm² Fastening torque for M4 screws: 1 Nm Operating temperature: -40...+105 °C (-40...+221 °F)</p>	<p>Material: PA ferrite Weight: Approx. 10 g Surface pressure: Max. 40 N/mm² Operating temperature: -40...+105 °C (-40...+221 °F)</p>	<p>Material: PA ferrite coated Weight: Approx. 13 g Surface pressure: Max. 20 N/mm² Operating temperature: -40...+100 °C (-40...+212 °F)</p>

Position magnet

Magnet spacer

O-rings

<p>Block magnet L Part no. 403 448</p>	<p>Magnet spacer Part no. 400 633</p>	<p>O-ring for threaded flange M18×1.5-6g Part no. 401 133</p>	<p>O-ring for threaded flange ¾"-16 UNF-3A Part no. 560 315</p>
<p>Material: Plastic carrier with hard ferrite magnet Weight: Approx. 20 g Fastening torque for M4 screws: 1 Nm Operating temperature: -40...+75 °C (-40...+167 °F)</p> <p>This magnet may influence the sensor performance specifications for some applications.</p>	<p>Material: Aluminum Weight: Approx. 5 g Surface pressure: Max. 20 N/mm² Fastening torque for M4 screws: 1 Nm</p>	<p>Material: Fluoroelastomer Durometer: 75 ± 5 Shore A Operating temperature: -40...+204 °C (-40...+400 °F)</p>	<p>Material: Fluoroelastomer Durometer: 75 ± 5 Shore A Operating temperature: -40...+204 °C (-40...+400 °F)</p>

O-ring

Mounting accessories

<p>O-ring for threaded flange M22×1.5-6g Part no. 561 337</p>	<p>Hex jam nut M18×1.5-6g Part no. 500 018</p>	<p>Hex jam nut ¾"-16 UNF-3A Part no. 500 015</p>	<p>Fixing clip Part no. 561 481</p>
<p>Material: FPM Durometer: 75 Shore A Operating temperature: -20...+200 °C (-6...+392 °F)</p>	<p>Material: Steel, zinc plated</p>	<p>Material: Steel, zinc plated</p>	<p>Application: Used to secure sensor rods (Ø 10 mm (Ø 0.39 in.)) when using an U-magnet or block magnet Material: Brass, non-magnetic</p>

4.12 Frequently ordered accessories for Temposonics® RM5 – Additional options available in our [Accessories Catalog](#) 551 444

Position magnets

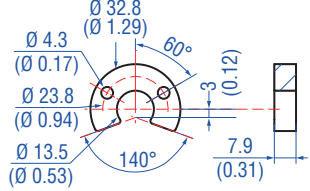
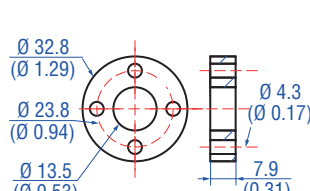
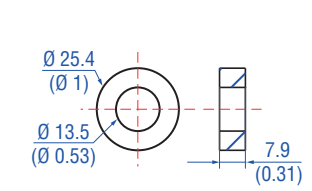
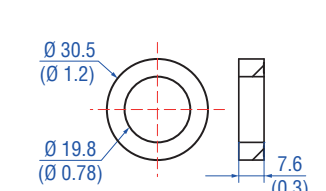
			
<p>U-magnet OD33 Part no. 251 416-2</p> <p>Material: PA ferrite GF20 Weight: Approx. 11 g Surface pressure: Max. 40 N/mm² Fastening torque for M4 screws: 1 Nm Operating temperature: -40...+105 °C (-40...+221 °F)</p>	<p>Ring magnet OD33 Part no. 201 542-2</p> <p>Material: PA ferrite GF20 Weight: Approx. 14 g Surface pressure: Max. 40 N/mm² Fastening torque for M4 screws: 1 Nm Operating temperature: -40...+105 °C (-40...+221 °F)</p>	<p>Ring magnet OD25.4 Part no. 400 533</p> <p>Material: PA ferrite Weight: Approx. 10 g Surface pressure: Max. 40 N/mm² Fastening torque: Operating temperature: -40...+105 °C (-40...+221 °F)</p>	<p>Ring magnet Part no. 402 316</p> <p>Material: PA ferrite coated Weight: Approx. 13 g Surface pressure: Max. 20 N/mm² Operating temperature: -40...+100 °C (-40...+212 °F)</p>



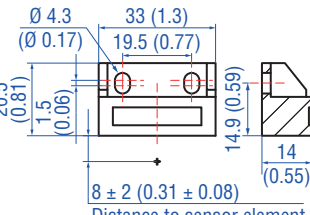
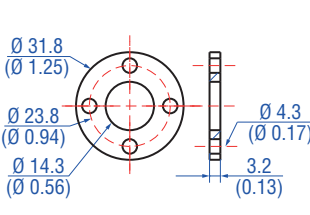
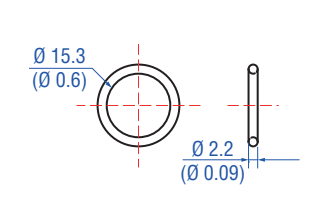
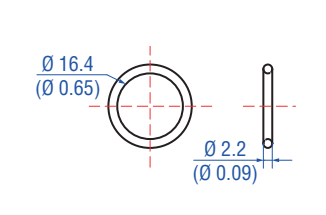

Position magnet Magnet spacer O-rings

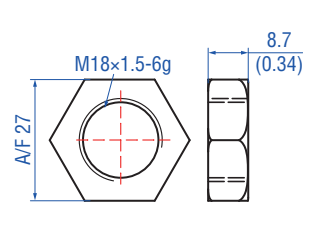
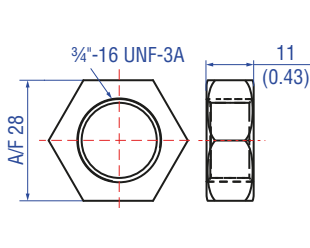
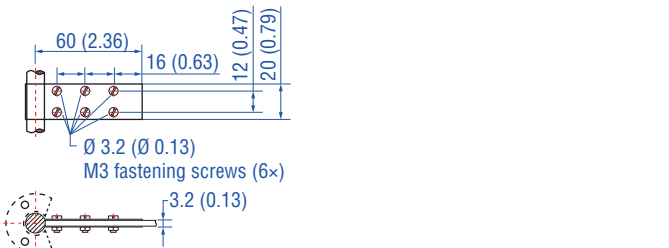
			
<p>Block magnet L Part no. 403 448</p> <p>Material: Plastic carrier with hard ferrite magnet Weight: Approx. 20 g Fastening torque for M4 screws: 1 Nm Operating temperature: -40...+75 °C (-40...+167 °F)</p> <p>This magnet may influence the sensor performance specifications for some applications.</p>	<p>Magnet spacer Part no. 400 633</p> <p>Material: Aluminum Weight: Approx. 5 g Surface pressure: Max. 20 N/mm² Fastening torque for M4 screws: 1 Nm</p>	<p>O-ring for threaded flange M18x1.5-6g Part no. 401 133</p> <p>Material: Fluoroelastomer Durometer: 75 ± 5 Shore A Operating temperature: -40...+204 °C (-40...+400 °F)</p>	<p>O-ring for threaded flange 3/4"-16 UNF-3A Part no. 560 315</p> <p>Material: Fluoroelastomer Durometer: 75 ± 5 Shore A Operating temperature: -40...+204 °C (-40...+400 °F)</p>

Mounting accessories

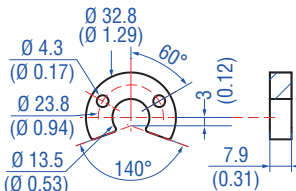
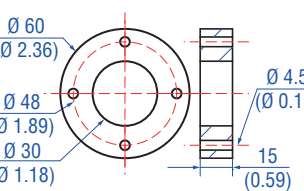
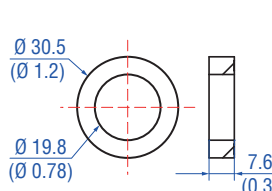
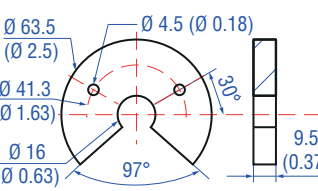
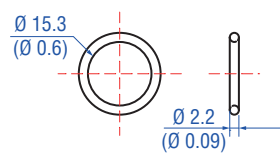
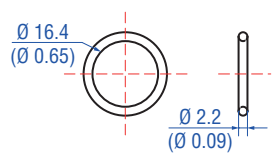
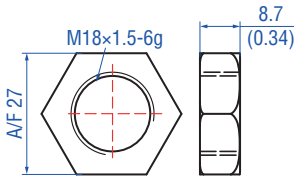
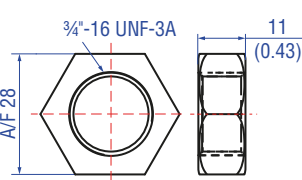
		
<p>Hex jam nut M18x1.5-6g Part no. 500 018</p> <p>Material: Steel, zinc plated</p>	<p>Hex jam nut 3/4"-16 UNF-3A Part no. 500 015</p> <p>Material: Steel, zinc plated</p>	<p>Fixing clip Part no. 561 481</p> <p>Application: Used to secure sensor rods (Ø 10 mm (Ø 0.39 in.)) when using an U-magnet or block magnet Material: Brass, non-magnetic</p>

4.13 Frequently ordered accessories for Temposonics® RFV – Additional options available in our [Accessories Catalog](#) 551 444

Position magnets			
			
<p>U-magnet OD33 Part no. 251 416-2</p> <p>Material: PA ferrite GF20 Weight: Approx. 11 g Surface pressure: Max. 40 N/mm² Fastening torque for M4 screws: 1 Nm Operating temperature: -40...+105 °C (-40...+221 °F)</p>	<p>Ring magnet OD60 Part no. MT0162</p> <p>Material: AlCuMgPb, magnets compound-filled Weight: Approx. 90 g Surface pressure: Max. 20 N/mm² Fastening torque for M4 screws: 1 Nm Operating temperature: -40...+75 °C (-40...+167 °F)</p>	<p>Ring magnet Part no. 402 316</p> <p>Material: PA ferrite coated Weight: Approx. 13 g Surface pressure: Max. 20 N/mm² Operating temperature: -40...+100 °C (-40...+212 °F)</p>	<p>U-magnet OD63.5 Part no. 201 553</p> <p>Material: PA 66-GF30, magnets compound-filled Weight: Approx. 26 g Surface pressure: 20 N/mm² Fastening torque for M4 screws: 1 Nm Operating temperature: -40...+75 °C (-40...+167 °F)</p>
O-rings		Mounting accessories	
			
<p>O-ring for threaded flange M18x1.5-6g Part no. 401 133</p> <p>Material: Fluoroelastomer Durometer: 75 ± 5 Shore A Operating temperature: -40...+204 °C (-40...+400 °F)</p>	<p>O-ring for threaded flange ¾"-16 UNF-3A Part no. 560 315</p> <p>Material: Fluoroelastomer Durometer: 75 ± 5 Shore A Operating temperature: -40...+204 °C (-40...+400 °F)</p>	<p>Hex jam nut M18x1.5-6g Part no. 500 018</p> <p>Material: Steel, zinc plated</p>	<p>Hex jam nut ¾"-16 UNF-3A Part no. 500 015</p> <p>Material: Steel, zinc plated</p>
Mounting accessories			
			
<p>Threaded flange M18x1.5-6g Part no. 404 874</p> <p>Material: Stainless steel 1.4305 (AISI 303)</p>	<p>Threaded flange ¾"-16 UNF-3A Part no. 404 875</p> <p>Material: Stainless steel 1.4305 (AISI 303)</p>	<p>Adapter plate Part no. 255 198</p> <p>Adapter plate for mounting an RFV-B as replacement for an RF-C. Order the RFV-B with the addition H003</p>	

Controlling design dimensions are in millimeters and measurements in () are in inches

Mounting accessories



Sensor rod with threaded flange with flat-face (M18x1.5-6g) and O-ring
HD [length mm: XXXX] M
HD [length in.: XXX.X] U

Sensor rod with threaded flange with flat-face (3/4"-16 UNF-3A) and O-ring
HL [length mm: XXXX] M
HL [length in.: XXX.X] U

Sensor rod with threaded flange with raised-face (3/4"-16 UNF-3A) and O-ring
HP [length mm: XXXX] M
HP [length in.: XXX.X] U

Profile with flange
HFP [length mm: XXXXX] M
HFP [length in.: XXXX.X] U

Pressure rod Ø: 12.7 mm (0.5 in.)
Length: 100...7500 mm (4...295 in.)
Operating pressure: 350 bar (5076 psi)
Material flange:
Stainless steel 1.4305 (AISI 303)
Material rod:
Stainless steel 1.4301 (AISI 304)

Pressure rod Ø: 12.7 mm (0.5 in.)
Length: 100...7500 mm (4...295 in.)
Operating pressure: 350 bar (5076 psi)
Material flange:
Stainless steel 1.4305 (AISI 303)
Material rod:
Stainless steel 1.4301 (AISI 304)

Pressure rod Ø: 12.7 mm (0.5 in.)
Length: 100...7500 mm (4...295 in.)
Operating pressure: 350 bar (5076 psi)
Material flange:
Stainless steel 1.4305 (AISI 303)
Material rod:
Stainless steel 1.4301 (AISI 304)

Length: Max. 20 000 mm (max. 787 in.)
Ingress protection: IP30
Material: Aluminum

4.14 Frequently ordered accessories for Temposonics® RDV – Additional options available in our [Accessories Catalog](#) 551 444

Position magnets

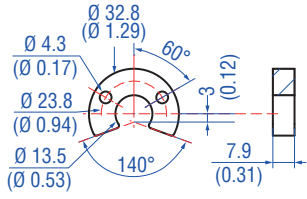
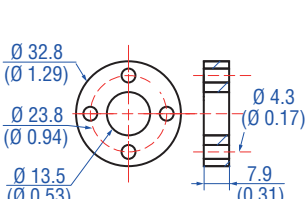
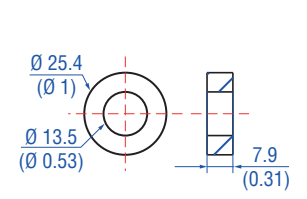
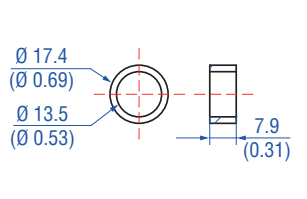
			
<p>U-magnet OD33 Part no. 251 416-2</p>	<p>Ring magnet OD33 Part no. 201 542-2</p>	<p>Ring magnet OD25.4 Part no. 400 533</p>	<p>Ring magnet OD17.4 Part no. 401 032</p>
<p>Material: PA ferrite GF20 Weight: Approx. 11 g Surface pressure: Max. 40 N/mm² Fastening torque for M4 screws: 1 Nm Operating temperature: -40...+105 °C (-40...+221 °F)</p>	<p>Material: PA ferrite GF20 Weight: Approx. 14 g Surface pressure: Max. 40 N/mm² Fastening torque for M4 screws: 1 Nm Operating temperature: -40...+105 °C (-40...+221 °F)</p>	<p>Material: PA ferrite Weight: Approx. 10 g Surface pressure: Max. 40 N/mm² Operating temperature: -40...+105 °C (-40...+221 °F)</p>	<p>Material: PA neobond Weight: Approx. 5 g Surface pressure: Max. 20 N/mm² Operating temperature: -40...+105 °C (-40...+221 °F)</p>

Magnet spacer

O-rings

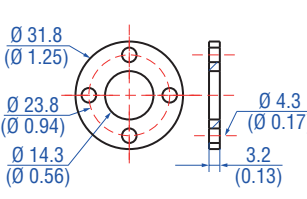
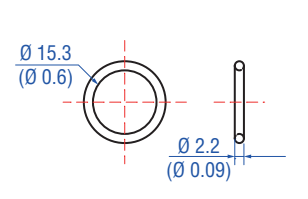
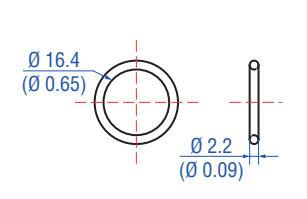
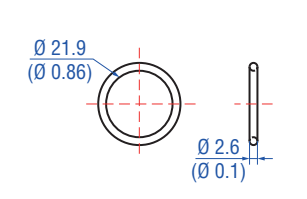
			
<p>Magnet spacer Part no. 400 633</p>	<p>O-ring for threaded flange M18x1.5-6g Part no. 401 133</p>	<p>O-ring for threaded flange 3/4"-16 UNF-3A Part no. 560 315</p>	<p>O-ring for pressure fit flange Ø 26.9 mm Part no. 560 705</p>
<p>Material: Aluminum Weight: Approx. 5 g Surface pressure: Max. 20 N/mm² Fastening torque for M4 screws: 1 Nm</p>	<p>Material: Fluoroelastomer Durometer: 75 ± 5 Shore A Operating temperature: -40...+204 °C (-40...+400 °F)</p>	<p>Material: Fluoroelastomer Durometer: 75 ± 5 Shore A Operating temperature: -40...+204 °C (-40...+400 °F)</p>	<p>Material: Nitrile rubber Operating temperature: -53...+107 °C (-65...+225 °F)</p>

O-rings

Mounting accessories

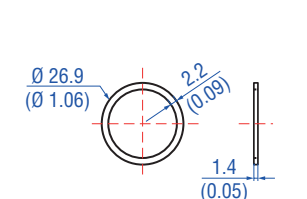
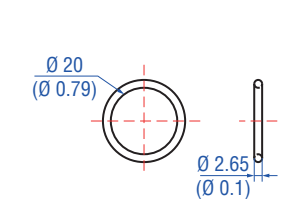
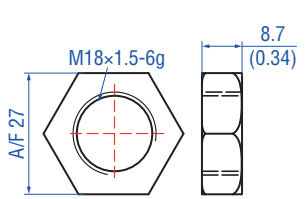
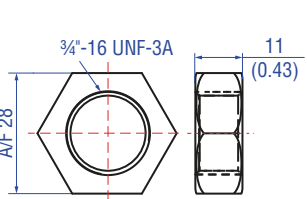
			
<p>Back-up ring for pressure fit flange Ø 26.9 mm Part no. 560 629</p>	<p>O-ring for mounting block with bottom entry Part no. 561 435</p>	<p>Hex jam nut M18x1.5-6g Part no. 500 018</p>	<p>Hex jam nut 3/4"-16 UNF-3A Part no. 500 015</p>
<p>Material: Polymyte Durometer: 90 Shore A</p>	<p>Material: FKM Durometer: 80 ± 5 Shore A Operating temperature: -15...+200 °C (5...+392 °F)</p>	<p>Material: Steel, zinc plated</p>	<p>Material: Steel, zinc plated</p>

Mounting accessories

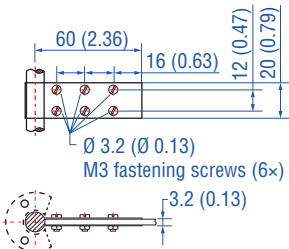

Fixing clip
Part no. 561 481

Application: Used to secure sensor rods (Ø 10 mm (Ø 0.39 in.)) when using an U-magnet or block magnet
Material: Brass, non-magnetic



Controlling design dimensions are in millimeters and measurements in () are in inches

4.15 Frequently ordered accessories for Analog output – Additional options available in our [Accessories Catalog](#) 551 444

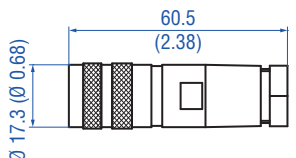
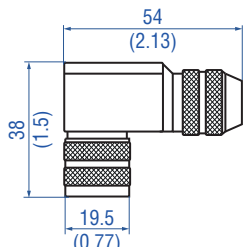
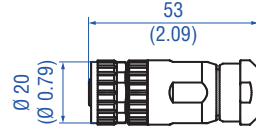
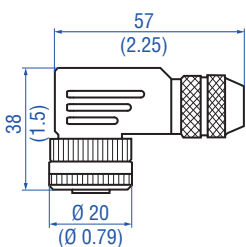

Cable connectors*

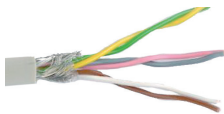
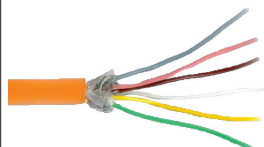

			
<p>M16 female connector (6 pin), straight Part no. 370 423</p>	<p>M16 female connector (6 pin), angled Part no. 370 460</p>	<p>M12 A-coded female connector (4 pin/5 pin), straight Part no. 370 677</p>	<p>M12 A-coded female connector (5 pin), angled Part no. 370 678</p>
<p>Material: Zinc nickel plated Termination: Solder Cable Ø: 6...8 mm (0.24...0.31 in.) Operating temperature: -40...+100 °C (-40...+212 °F) Ingress protection: IP65/IP67 (correctly fitted) Fastening torque: 0.6 Nm</p>	<p>Material: Zinc nickel plated Termination: Solder Cable Ø: 6...8 mm (0.24...0.31 in.) Wire: 0.75 mm² (20 AWG) Operating temperature: -40...+95 °C (-40...+203 °F) Ingress protection: IP67 (correctly fitted) Fastening torque: 0.6 Nm</p>	<p>Material: GD-Zn, Ni Termination: Screw Contact insert: CuZn Cable Ø: 4...8 mm (0.16...0.31 in.) Wire: 1.5 mm² Operating temperature: -30...+85 °C (-22...+185 °F) Ingress protection: IP67 (correctly fitted) Fastening torque: 0.6 Nm</p>	<p>Material: GD-Zn, Ni Termination: Screw; max. 0.75 mm² Contact insert: CuZn Cable Ø: 5...8 mm (0.2...0.31 in.) Wire: 0.75 mm² (18 AWG) Operating temperature: -25...+85 °C (-13...+185 °F) Ingress protection: IP67 (correctly fitted) Fastening torque: 0.4 Nm</p>

Cables

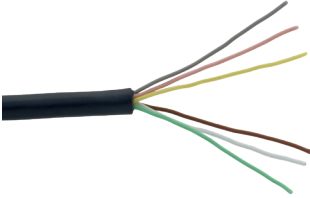
			
<p>PVC cable Part no. 530 032</p>	<p>PUR cable Part no. 530 052</p>	<p>FEP cable Part no. 530 112</p>	<p>FEP cable Part no. 530 157</p>
<p>Material: PVC jacket; gray Features: Twisted pair, shielded, flexible Cable Ø: 6 mm (0.23 in.) Cross section: 3 × 2 × 0.14 mm² Bending radius: 10 × D (fixed installation) Operating temperature: -40...+105 °C (-40...+221 °F)</p>	<p>Material: PUR jacket; orange Features: Twisted pair, shielded, highly flexible, halogen free, suitable for drag chains, mostly oil & flame resistant Cable Ø: 6.4 mm (0.25 in.) Cross section: 3 × 2 × 0.25 mm² Bending radius: 5 × D (fixed installation) Operating temperature: -30...+80 °C (-22...+176 °F)</p>	<p>Material: FEP jacket; black Features: Twisted pair, shielded, flexible, high thermal resistance, mostly oil & acid resistant Cable Ø: 7.6 mm (0.3 in.) Cross section: 4 × 2 × 0.25 mm² Bending radius: 8 – 10 × D (fixed installation) Operating temperature: -100...+180 °C (-148...+356 °F)</p>	<p>Material: FEP jacket; black Features: Twisted pair, shielded Cable Ø: 6.7 mm (0.26 in.) Cross section: 3 × 2 × 0.14 mm² Operating temperature: -40...+180 °C (-40...+356 °F)</p>



*/ Follow the manufacturer's mounting instructions
Color of connectors and cable jacket may change. Color codes for the individual wires and technical properties remain unchanged.
Controlling design dimensions are in millimeters and measurements in () are in inches

Cable	Cable sets	
		
<p>Silicone cable Part no. 530 176</p> <p>Material: Silicone jacket; black Features: Twisted pair, shielded Cable Ø: 6.3 mm (0.25 in.) Cross section: 3 × 2 × 0.14 mm² Bending radius: 7 × D (fixed installation) Operating temperature: -50...+150 °C (-58...+302 °F)</p>	<p>Cable with M12 A-coded female connector (5 pin), straight – pigtail Part no. 370 673</p> <p>Material: PUR jacket; black Features: Shielded Cable length: 5 m (16.4 ft) Ingress protection: IP67 (correctly fitted) Operating temperature: -25...+80 °C (-13...+176 °F)</p>	<p>Cable with M12 A-coded female connector (5 pin), angled – pigtail Part no. 370 675</p> <p>Material: PUR jacket; black Features: Shielded Cable length: 5 m (16.4 ft) Ingress protection: IP67 (correctly fitted) Operating temperature: -25...+80 °C (-13...+176 °F)</p>



Programming tools		
		
<p>Hand programmer for analog output Part no. 253 124</p> <p>Easy teach-in-setups of stroke length and direction on desired zero / span positions. For sensors with 1 magnet.</p>	<p>Cabinet programmer for analog output Part no. 253 408</p> <p>Features snap-in mounting on standard DIN rail (35 mm). This programmer can be permanently mounted in a control cabinet and includes a program/run switch. For sensors with 1 magnet.</p>	<p>TempoLink® kit for Temposonics® R-Series V Part no. TL-1-0-AD60 (for D60) Part no. TL-1-0-AS00 (for cable outlet) Part no. TL-1-0-AD34 (for D34)</p> <ul style="list-style-type: none"> • Connect wirelessly via Wi-Fi enabled device or via USB with the diagnostic tool • Simple connectivity to the sensor via 24 VDC power line (permissible cable length: 30 m) • User friendly interface for mobile devices and desktop computers • See data sheet “TempoLink® smart assistant” (document part no.: 552070) for further information

Controlling design dimensions are in millimeters and measurements in () are in inches
Color of connectors and cable jacket may change. Color codes for the individual wires and technical properties remain unchanged.

Extension cables M12

		
<p>PVC cable with M12 female connector (6 pin), straight – pigtail</p>	<p>PUR cable with M12 female connector (6 pin), straight – pigtail</p>	<p>FEP cable with M12 female connector (6 pin), straight – pigtail</p>
<p>PVC cable (part no. 530 032) with M12 female connector, straight (part no. 370 677)</p> <p>Order code: K2-A-370677-xxxxyy-530032-0 (where xxxx = cable length and yy = unit in centimeters “CM” or feet “FT”)</p>	<p>PUR cable (part no. 530 052) with M12 female connector, straight (part no. 370 677)</p> <p>Order code: K2-A-370677-xxxxyy-530052-0 (where xxxx = cable length and yy = unit in centimeters “CM” or feet “FT”)</p>	<p>FEP cable (part no. 530 112) with M12 female connector, straight (part no. 370 677)</p> <p>Order code: K2-A-370677-xxxxyy-530112-0 (where xxxx = cable length and yy = unit in centimeters “CM” or feet “FT”)</p>

Extension cables M16

		
<p>PVC cable with M16 female connector (6 pin), straight – pigtail</p>	<p>PUR cable with M16 female connector (6 pin), straight – pigtail</p>	<p>FEP cable with M16 female connector (6 pin), straight – pigtail</p>
<p>PVC cable (part no. 530 032) with M16 female connector, straight (part no. 370 423)</p> <p>Order code: K2-A-370423-xxxxyy-530032-0 (where xxxx = cable length and yy = unit in centimeters “CM” or feet “FT”)</p>	<p>PUR cable (part no. 530 052) with M16 female connector, straight (part no. 370 423)</p> <p>Order code: K2-A-370423-xxxxyy-530052-0 (where xxxx = cable length and yy = unit in centimeters “CM” or feet “FT”)</p>	<p>FEP cable (part no. 530 112) with M16 female connector, straight (part no. 370 423)</p> <p>Order code: K2-A-370423-xxxxyy-530112-0 (where xxxx = cable length and yy = unit in centimeters “CM” or feet “FT”)</p>

Color of connectors and cable jacket may change. Color codes for the individual wires and technical properties remain unchanged.

5. Commissioning

5.1 Getting started

Analog interface

The analog sensor can be directly connected to a controller. Its electronics generates a position signal output proportional to the start and the end of the active measuring range. In this case, the sensor is set at the factory according to the order code, so that the desired output signal corresponds exactly to the selected stroke length, e.g.:

Output 4...20 mA = 0...100 % of the stroke length

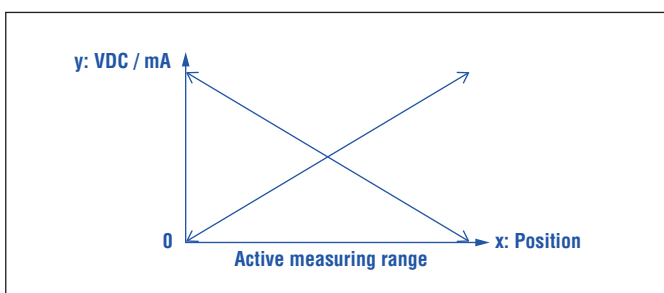

Fig. 64: Analog interface

NOTICE

Observe during commissioning

1. Before initial switch-on, check carefully if the sensor has been connected correctly.
2. Position the magnet in the measuring range of the sensor during first commissioning and after replacement of the magnet.
3. Ensure that the sensor control system cannot react in an uncontrolled way when switching on.
4. Ensure that the sensor is ready and in operation mode after switching on. The status LED lights up permanently green.
5. Check the pre-set span start and end values of the measuring range (see chapter 4.7) and correct them via the TempoLink® smart assistant, if necessary.

5.2 Analog output options

The R-Series V Analog can be configured with one or two outputs.

Possibilities with one output

- Output the magnet position value as current or voltage value
- Output the difference or the distance between two magnets as current or voltage value

Possibilities with two outputs

- Output the magnet position value on output 1 and output the speed (without indication of the measuring direction) or velocity (with indication of the measuring direction) of the magnet on output 2
- Output the magnet position value on output 1 and output the inverted magnet position value on output 2. This can be used to check the signal, since the sum of the two output values is always identical.
- Output the magnet position value on output 1 and output the temperature inside the sensor electronics housing on output 2. This can be used to check the signal, since an excessive increase of the temperature indicates a defect.

5.3 LED status

The LED on the sensor visualizes the current sensor status. In normal function the LED is continuously green. In other cases the color of the LED changes in the time slot of 0.5 seconds as shown in Fig. 65.

R-Series V Analog LED status

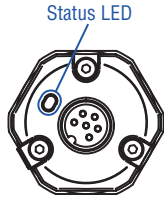

Time slot 1	Time slot 2	Time slot 3	Time slot 4	Information
GN	GN	GN	GN	Normal function
GN	BU	RD	Off	Configuration error
BU	GN	RD	Off	Storage error
BU	RD	GN	Off	Internal error
RD	Off	RD	Off	Power supply error
GN	Off	GN	Off	Magnet outside set points
GN	RD	BU	Off	Extra magnet
RD + GN	RD + GN	RD + GN	RD + GN	Magnet status error
RD	BU	GN	Off	Signal error
BU	Off	BU	Off	Command mode

1 × time slot = 0.5 seconds

Fig. 65: LED status

Fig. 66 describes error conditions that are output via the LEDs and troubleshooting.

Error Condition	Description	Troubleshooting
Configuration Error	Invalid configuration of the sensor	Check the configuration of the sensor. Contact Temposonics.
Storage Error	Error in internal data storage	Contact Temposonics
Internal Error	Internal error of the sensor	Contact Temposonics
Power Supply Error	Power supply of the sensor is out of the allowable range	Set the power supply for the sensor to the allowable range
Magnet outside set points	Position magnet is not in the range between set point 1 and set point 2	Ensure that the position magnet remains within the defined set point range, or program new set point positions
Extra Magnet	Sensor registers more position magnets than set	Ensure that the number of position magnets on the sensor matches the set number
Magnet Status Error	Sensor registers less position magnets than set	Ensure that the number of position magnets on the sensor matches the set number
Signal Error	Internal signal error	Contact Temposonics
Position Error	Error in position measurement	Contact Temposonics

Fig. 66: Error conditions and troubleshooting

5.4 Adjustment of sensor settings on-site

Temposonics® R-Series V Analog sensors are factory set according to the order code. These the default sensor settings fit for many applications. To adjust sensor settings in the field, there are three programming tools:

- The TempoLink® smart assistant (see chapter 5.4.1)
- The hand programmer (see chapter 5.4.6)
- The cabinet programmer (see chapter 5.4.7)

The hand programmer and the cabinet programmer are used to program the start value (0 %) and the end value (100 %) of the first output of the R-Series V Analog. To set other current or voltage values for the start point and the end point of the measuring range or to adjust the second output of the sensor use the TempoLink® smart assistant. In addition to adjusting the sensor parameters, the TempoLink® smart assistant can be used to retrieve information on the sensor status and operational data for diagnostics.

Fig. 67 shows an example of a shift of the start value (set point 1) and the end value (set point 2). Fig. 68 represents a reversal of the measuring direction by adjusting the start value (set point 1) and the end value (set point 2).

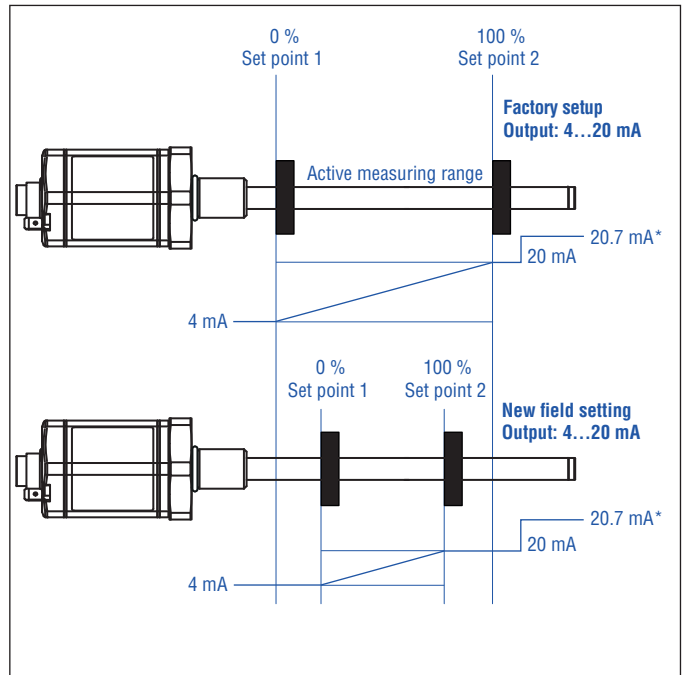

Fig. 67: Shifting the start position (set point 1) and end position (set point 2)

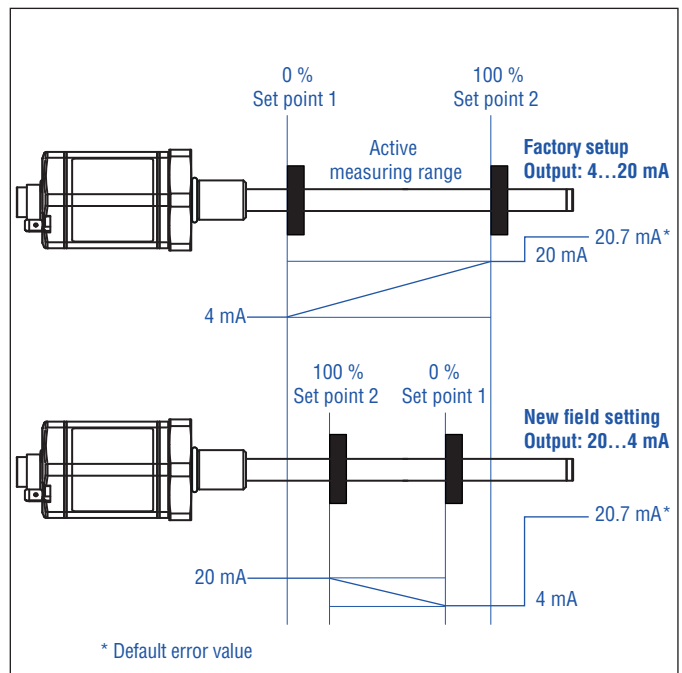

Fig. 68: Reversal of the measuring direction by adjusting the start value (set point 1) and the end value (set point 2)

5.4.1 Customization of the R-Series V via the TempoLink® smart assistant

The TempoLink® smart assistant can be connected to all R-Series V sensors. Use the adapter cable for connection of the TempoLink® smart assistant to the R-Series V. If the sensor is connected to a control system, disconnect the sensor from that control system before connecting the TempoLink® smart assistant to the sensor. Connect the barrel connector of the adapter cable to the connection point labeled “OUTPUT SENSOR” on the TempoLink® smart assistant (Fig. 69).

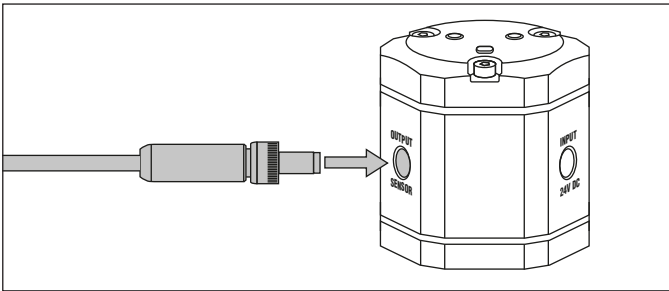

Fig. 69: Connection of adapter cable to TempoLink® smart assistant

- NOTICE**
- When disconnecting the power supply of the sensor, possibly error messages occur at the connected control system.
 - Do not exceed the maximum cable length between TempoLink® smart assistant and R-Series V sensor of 30 m (99 ft.).

1. Connection to a sensor with connector outlet

Connect the other end of the adapter cable to the R-Series V. The sensor is powered by the TempoLink® smart assistant (Fig. 70).

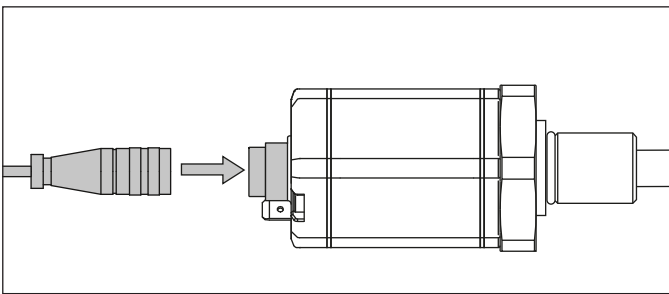

Fig. 70: Connection of adapter cable to R-Series V sensor with connector outlet

2. Connection to a sensor with cable outlet

Connect the pig-tails of the sensor cable to the terminal clamps of the adapter cable according to the connector wiring in Fig. 71 (Fig. 72).

Color sensor cable	Color adapter cable	Function
GY	GY	–
PK	PK	–
YE	YE	–
GN	GN	–
BN	BN	+ 24 VDC
WH	WH	DC Ground (0 V)

Fig. 71: Connection of adapter cable to sensor cable

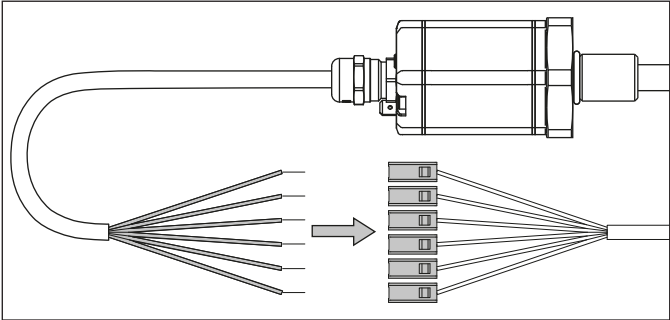

Fig. 72: Connection of adapter cable to R-Series V sensor with cable outlet

5.4.2 Connection of TempoLink® smart assistant to power supply

Connect the barrel connector of the power supply to the connection point labeled “INPUT 24 VDC” on the TempoLink® smart assistant (Fig. 73).

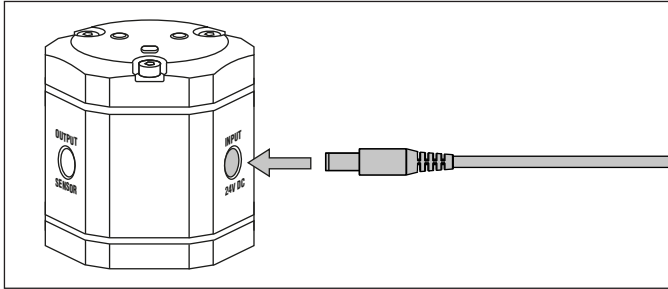

Fig. 73: Connection of power supply to the TempoLink® smart assistant

There are two ways to connect the TempoLink® smart assistant to a power supply:

1. Connection via the plug-in power supply with plug adapters

Attach the plug attachment suitable for your country to the plug. Insert the plug into the outlet (Fig. 74).

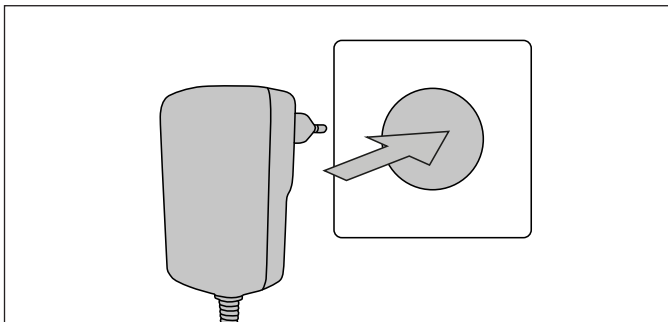

Fig. 74: Connection of the plug-in power supply to the outlet

2. Connection via the cable with barrel connector and pig-tail

Connect the cable to a power supply according to the connector wiring in Fig. 75 (Fig. 76).

Cable	Function
● RD	+24 VDC
● BK	DC Ground (0 V)

Fig. 75: Connector wiring cable

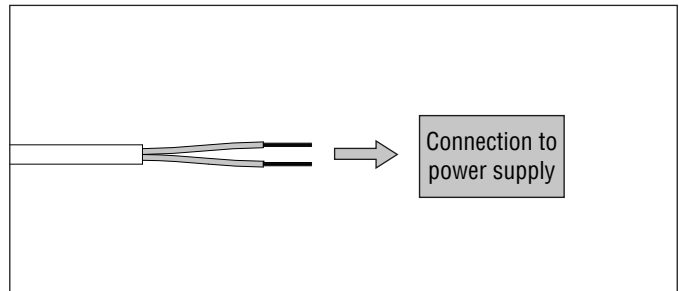

Fig. 76: Connection of cable with barrel connector and pig-tails

5.4.3 Connection of TempoLink® smart assistant to smartphone, tablet or computer

Connect to a smartphone, tablet or computer to display the graphical user interface of the TempoLink® smart assistant.

Connecting a Wi-Fi enabled device to the integrated Wi-Fi access point³

Activate Wi-Fi on the device and choose the network “TempoLink_xxxx” (xxxx indicates the last four digits of the serial number). The access to the Wi-Fi network is password protected. The default password is the serial number printed on the label on the bottom of the TempoLink® smart assistant.

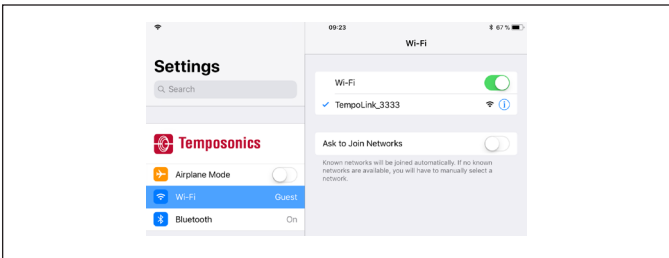

Fig. 77: Choose the network “TempoLink_xxxx” in the Wi-Fi settings of the Wi-Fi-enabled device

NOTICE
If you are using a mobile device, ensure cellular data is off. Depending on your operation system, message can appear, that there is no internet access. TempoLink® smart assistant does not need internet access. Connecting to the user interface may take longer if Wi-Fi and cellular data are active.

Connecting a computer via USB connection

The TempoLink® smart assistant can also be connected via USB. If the computer is Wi-Fi enabled deactivate Wi-Fi on the computer before setting up the USB connection.

1. Connect the USB cable with the micro USB connector to the port labeled “USB” on the TempoLink® smart assistant (Fig. 78).
2. Next, connect the USB type-A connector to a free USB port of the computer. The USB connection simulates a network card. In the folder “network connections” on the computer the connection is shown as “IP-over-USB” or “Remote NDIS”.

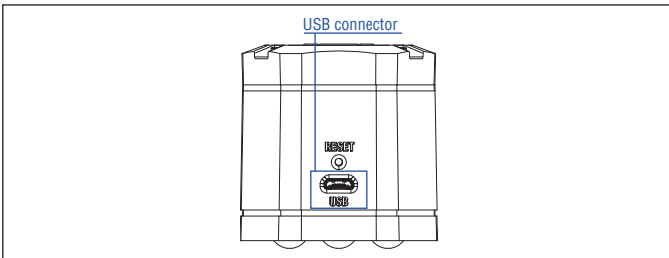

Fig. 78: USB port on the TempoLink® smart assistant

NOTICE

- Only one device can be connected to the TempoLink® smart assistant at a time in order to display the graphical user interface.
- Disable all Wi-Fi and LAN connections before connecting TempoLink® smart assistant via USB. Connecting to the user interface may take longer if Wi-Fi and LAN connections are active.
- Should the website do not build up, it may be useful to press CTRL + F5 to delete cached text and images from prior to launching the <http://tempolink.local> website.

5.4.4 Establishing a connection via browser

After the connection via Wi-Fi or USB is established, open the browser on your mobile device or computer and go to the website-URL: <http://tempolink.local>
It is recommended to use the browser Mozilla Firefox, Google Chrome, Microsoft Edge or Apple Safari.

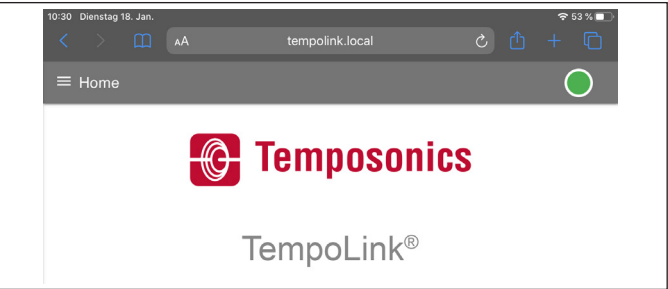

Fig. 79: Main menu of the graphical user interface

Connection status	
Green	Information
● ON	Connection to sensor is established
Red	Information
● ON	Connection to sensor is not established
Blue	Information
● ON	Sensor in command mode

Fig. 80: Connection status

^{3/} The integrated Wi-Fi access point does not provide internet access.

5.4.5 Graphical user interface

Click the menu symbol  in the top left to get to the main menu of the graphical user interface (GUI) (Fig. 81):

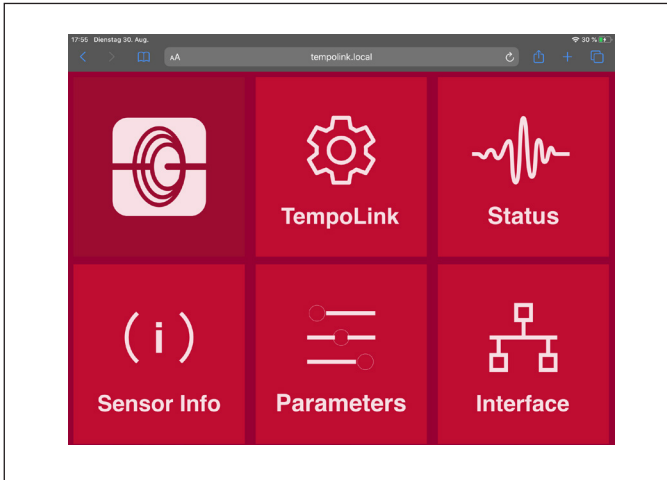

Fig. 81: Main menu of the graphical user interface

NOTICE

Read the TempoLink® smart assistant operation manual (document part number: [551986](#)) for more information.

Menu item TempoLink

Includes information about the TempoLink® smart assistant.

Menu item Status

Includes information about the sensor status.

Menu item Sensor Info

Includes information about the connected sensor.

Menu item Parameters

Includes information about the operational settings of the connected sensor.

Via the DOWNLOAD button you can save the settings of the sensor in a cek file on your computer (Fig. 82). The file is saved in the location according to your browser settings.

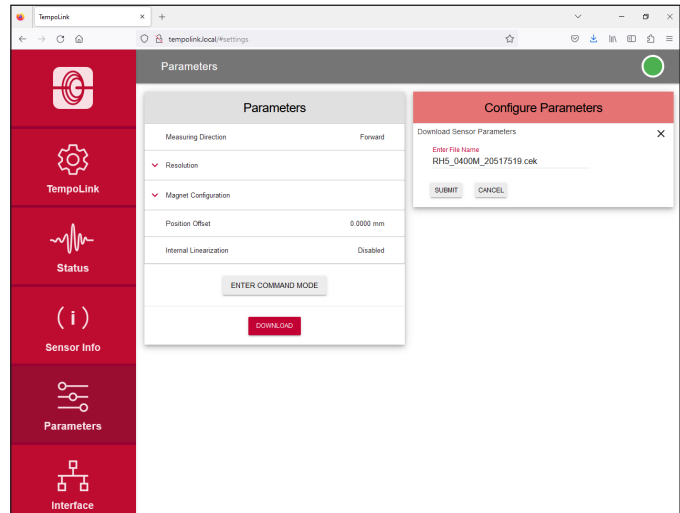

Fig. 82: Download a cek file with the settings of the sensor

You can upload this cek file to a sensor via the UPLOAD button (Fig. 83). In this way, you can e.g. transfer the settings to another R-Series V Analog sensor with the same stroke length. Uploading a cek file to a sensor is only possible in the “Command Mode”, which is described in the following section “Menu item Interface” on page 61. After clicking the button UPLOAD a new window opens. Click the CHOOSE FILE button and navigate to the location of the cek file that you want to upload. The selected file is displayed in the “File Selected” field. Click the SUBMIT button to execute uploading the cek file to the connected sensor.

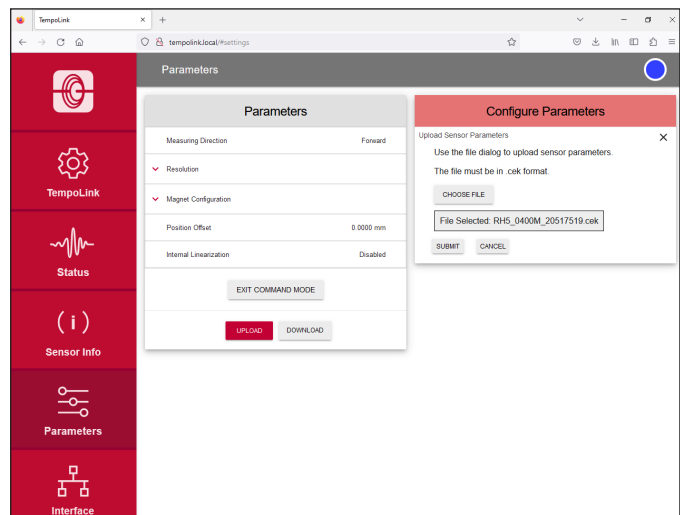

Fig. 83: Uploading a cek file to an R-Series V Analog sensor with the same stroke length

Menu item Interface

Includes information about the analog settings of the sensor (Fig. 84).

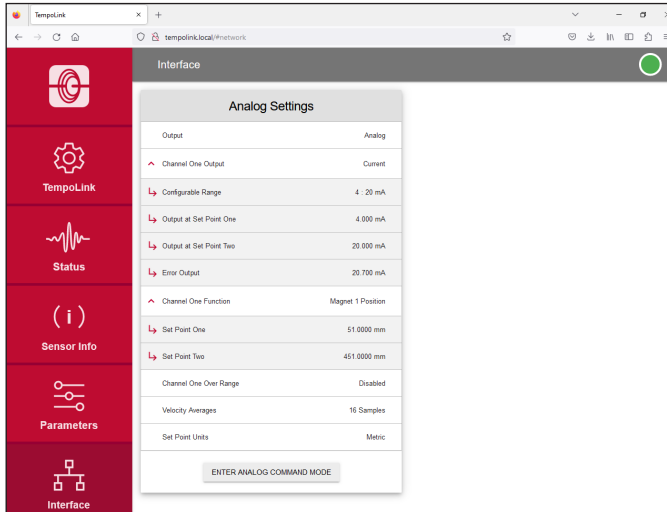

Fig. 84: R-Series V Analog settings

To change analog settings of the sensor, you must start the “Analog Command Mode”. In “Analog Command Mode”, the sensor does not output a position value. When you click the ENTER ANALOG COMMAND MODE button, a new window opens. After reading the information, enter the word COMMAND and confirm by clicking the OK button (Fig. 85).

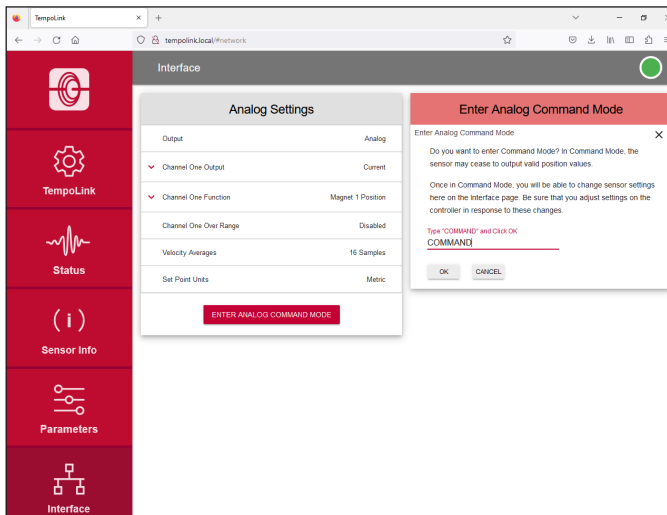

Fig. 85: Start Command Mode

After entering the “Analog Command Mode”, the connection icon on the top right will turn from green to blue. The status LED of the sensor also flashes blue. A pencil icon will appear to the right of parameter values. By clicking the pencil icon a new window for configuring the parameters will open. Adjust the parameter and confirm the change by clicking the SUBMIT button. The following parameters can be adjusted:

- Channel One Output: Settings of the output range and the output values for the first output. By clicking the red arrow to the left of “Channel One Output” unfolds the following entries:
 - Configurable Range: Setting the output range by specifying the output value at the beginning and the end of the measuring range. The default value corresponds to the order code.
 - Output at Set Point One: Setting the current or voltage value at the start of the measuring range. The default value corresponds to the order code for the beginning of the measuring range.
 - Output at Set Point Two: Setting the current or voltage value at the end of the measuring range. The default value corresponds to the order code for the end of the measuring range.
 - Error Output: Setting the value which is transmitted in case of an error. The default value is 20.7 mA for the current output or 10.4 V for the voltage output.
- Channel One Function: Setting the function that is reported at the first output (the default value corresponds to the order code):
 - Magnet 1 Position: Output the position for the first magnet
 - Magnet 1 Velocity: Output the velocity with indication of the measuring direction for the first magnet
 - Magnet 1 Speed: Output the speed without indication of the the measuring direction for the first magnet
 - Temperature: Output the temperature in the sensor electronics housing

By clicking on the red arrow ▼ to the left of “Channel One Function”, the following entries will open:

- **Set Point One:** Setting the start position of the measuring range. You can enter a value in the field or click the READ MAGNET button to retrieve the currently measured position value of the magnet.
- **Set Point Two:** Setting the end position of the measuring range. You can enter a value in the field or click the READ MAGNET button to retrieve the currently measured position value of the magnet.
- **Channel One Over Range (over range output mode):** Setting the behavior when the magnet leaves the output range (the default value corresponds to the order code).
 - **Enable:** When the magnet leaves the active measurement range, the output current or voltage value continues to rise or fall.
 - **Disable:** When the magnet leaves the active measuring range, the current or voltage value remains at the value of the start or the end of the measuring range. If the magnet enters the active measuring range again, the current or voltage value changes according to the position.
- **Channel Two Output (only for sensors with second output):** Settings of the output range and the output values for the second output. By clicking the red arrow ▼ to the left of “Channel Two Output”, the following entries will open:
 - **Configurable Range:** Setting the output range for the second output by specifying the output value at the start and the end of the measuring range. The default value corresponds to the order code.
 - **Output at Set Point One:** Setting the current or voltage value for the second output at the beginning of the measuring range. The default value corresponds to the order code for the start of the measuring range.
 - **Output at Set Point Two:** Setting the current or voltage value for the second output at the end of the measuring range. The default value corresponds to the order code for the end of the measuring range.
 - **Error Output:** Setting the value which is transmitted for the second output in case of an error. The default value is 20.7 mA for the current output or 10.4 V for the voltage output.
- **Channel Two Function (only for sensors with second output):** Setting of the function that is reported at the second output (the default value corresponds to the order code):
 - **Magnet 1 Position or Magnet 2 Position (depending on configuration):** Output the position for the first or the second magnet.
 - **Magnet 1 Velocity:** Output the velocity with indication of the measuring direction for the first magnet
 - **Magnet 1 Speed:** Output the speed without indication of the the measuring direction for the first magnet
 - **Temperature:** Output the temperature in the sensor electronics housing
- **Channel Two Over Range (over range output mode):** Setting the behavior when the magnet leaves the output range (the default value corresponds to the order code).
 - **Enable:** When the magnet leaves the active measurement range, the output current or voltage value continues to rise or fall.
 - **Disable:** When the magnet leaves the active measuring range, the current or voltage value remains at the value of the start or end of the measuring range. If the magnet enters the active measuring range again, the current or voltage value changes according to the position.
- **Velocity Averages (Velocity Windows Size):** Setting the number of position values for determining the velocity of the position magnet.
- **Set Point Units:** Setting the unit for the position values at the start and the end of measuring range (set points).
 - **Metric:** Metric unit (set points are specified in mm)
 - **Imperial:** Imperial unit (set points are specified in inches)

By clicking the button “FACTORY RESET” the sensor is reset to the factory setting. The “Factory Reset” window opens. Enter the word RESET and confirm by clicking the OK button, so that the sensor is re-set to the factory settings (Fig. 86).

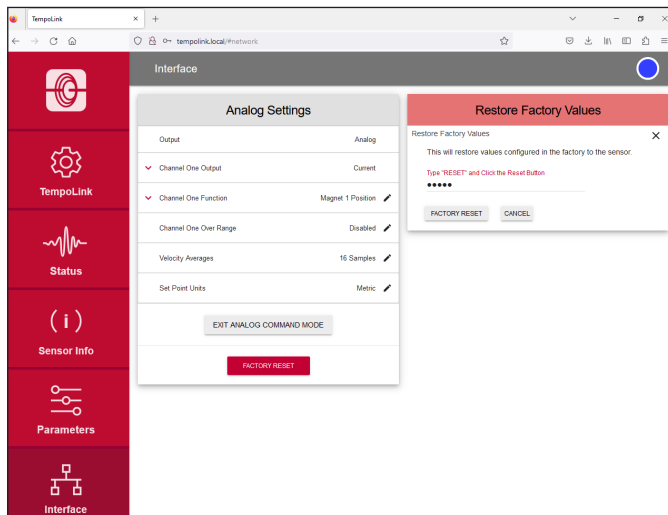

Fig. 86: Reset sensor to factory settings

After the parameters have been configured or the factory reset has been carried out, click the EXIT ANALOG COMMAND MODE button. The window for exiting the “Analog Command Mode” opens (Fig. 87). Click the SAVE AND EXIT button to exit the “Analog Command Mode” and to transfer the changed parameters to the sensor. If you click the EXIT WITHOUT SAVING button, the changes you have made will not be transferred to the sensor. In both cases the sensor returns to the normal function and outputs the current position value. The connection icon on the top right will turn to green. The status LED of the sensor lights up green.

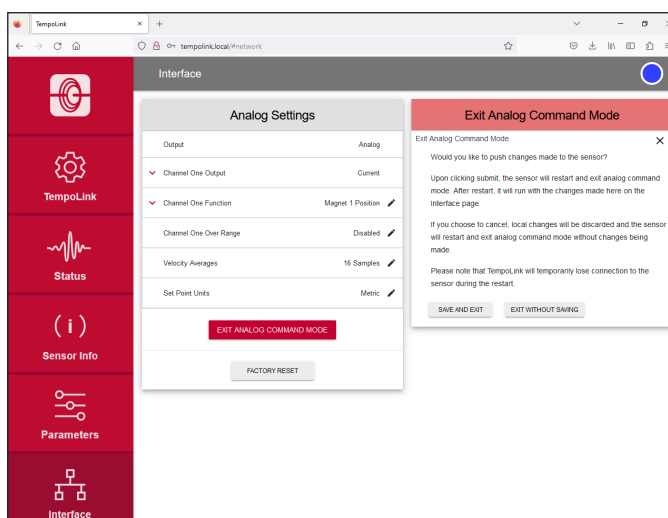

Fig. 87: Exit Command Mode

5.4.6 Adjusting the R-Series V Analog via the hand programmer

It is possible to change the set points (start and end position) as well as the measuring direction via simple teach in process. Move the position magnet to the desired start or end position and push the corresponding “0 %” or “100 %” button on the hand programmer. The minimum distance between the new set points is 25 mm (1 in.). The individual steps are explained in the following section:

Step 1: Connect hand programmer

Connect the hand programmer to the power supply and to the sensor according to Fig. 88.

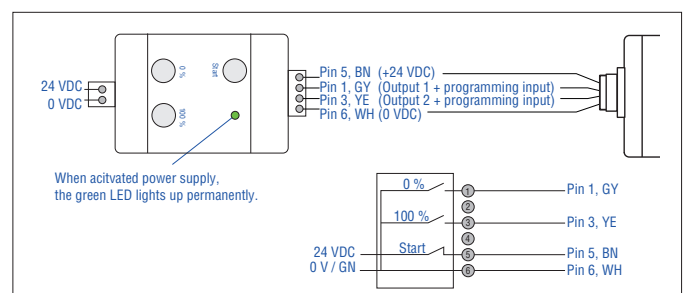

Fig. 88: Connect hand programmer

NOTICE

You can only adapt output 1 via hand programmer. In order to change the settings of output 1 you have to connect both outputs (output 1 and output 2).

Step 2: Adjust measuring range

1. Activate programming mode:
 - Press the “Start” and the “100 %” button simultaneously.
 - Release the “Start” button and wait until the LED on the sensor changes from permanently green to flashing blue. Release the “100 %” button.
 - The programming mode is activated: The LED on the sensor flashes blue.
2. Set start position (0 % output):
 - Set the position magnet to the desired start position.
 - Press the “0 %” button until the blue flashing LED on the sensor lights up permanently green.
 - Release the “0 %” button. The LED on the sensor flashes blue again.
3. Set end position (100 % output):
 - Set the position magnet to the desired end position.
 - Press the “100 %” button until the blue flashing LED on the sensor lights up permanently green.
 - Release the “100 %” button. The LED on the sensor flashes blue again.
4. Back to normal function (exit programming mode):
 - Press the “Start” button. The LED on the sensor changes from flashing blue to permanently green.
 - Switch off the power supply of the hand programmer and disconnect it from the sensor.

5.4.7 Adjusting the R-Series V Analog via the cabinet programmer

The cabinet programmer is installed in the control cabinet and connected between the sensor and the controller. It is possible to change the set points (start and end position) as well as the measuring direction via simple teach in process. Move the position magnet to the desired start or end position and push the corresponding “0 %” or “100 %” button on the hand programmer. The minimum distance between the new set points is 25 mm (1 in.). The individual steps are explained in the following section:

Step 1: Install cabinet programmer

Install the cabinet programmer on a 35 mm standard rail according to DIN EN 60715/50022 in a control cabinet (Fig. 89).

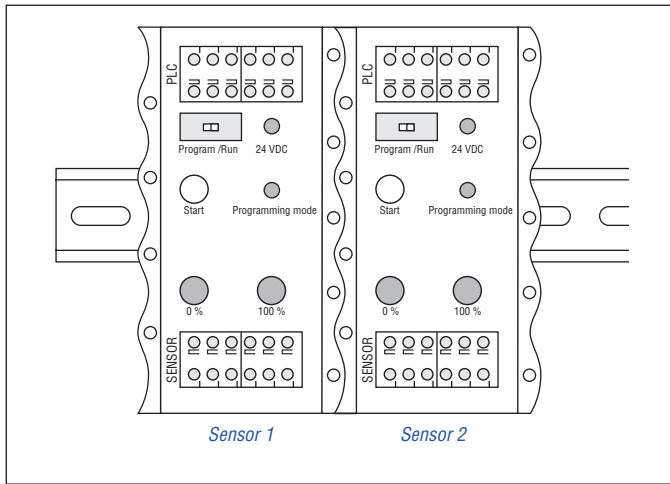

Fig. 89: Installation of cabinet programmer on a 35 mm standard rail

Step 2: Connect cabinet programmer

The cabinet programmer is integrated between the sensor and the controller. Connect the cabinet programmer to the controller, the power supply and the sensor as shown in Fig. 90. The spring terminals are suitable for cable wires with max. 1.5 mm². When the power supply is active, the “24 VDC” LED on the cabinet programmer lights up. Set the “Program/Run” slide switch to the “Run” position during normal operation.

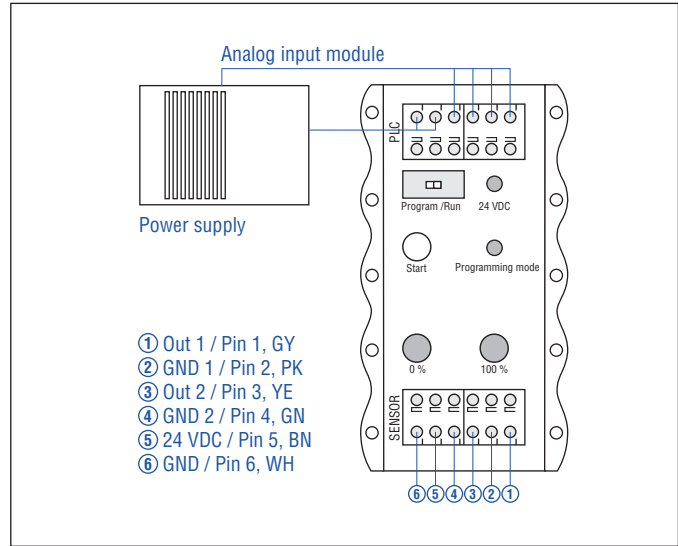

Fig. 90: Connect cabinet programmer

Step 3: Adjust measuring range

1. Activate programming mode:
 - Set the slide switch from the “Run” position to the “Program” position.
 - Press the “Start” and the “100 %” button simultaneously.
 - Release the “Start” button and wait until the LED on the sensor changes from steady green to flashing blue. Release the “100 %” button.
 - The programming mode is activated: the “Programming Mode” LED on the cabinet programmer flashes green and the LED on the sensor flashes blue.
2. Set start position (0 % output):
 - Set the position magnet to the desired start position.
 - Press the “0 %” button until the blue flashing LED on the sensor lights up permanently green.
 - Release the “0 %” button. The LED on the sensor flashes blue again.
3. Set end position (100 % output):
 - Set the position magnet to the desired end position.
 - Press the “100 %” button until the blue flashing LED on the sensor lights up permanently green.
 - Release the “100 %” button. The LED on the sensor flashes blue again.
4. Back to normal function (exit programming mode):
 - Press the “Start” button.
 - The “Programming mode” LED on the cabinet programmer stops flashing.
 - Set the slide switch from the “Program” position to the “Run” position.
 - The LED on the sensor changes from flashing blue to permanently green.

6. Maintenance and troubleshooting

6.1 Error conditions, troubleshooting

See chapter “5.3 LED status” on page 55.

6.2 Maintenance

The sensor is maintenance-free.

6.3 Repair

Repairs of the sensor may be performed only by Temposonics or a repair facility explicitly authorized by Temposonics. For return see chapter “2.6 Return” on page 4.

6.4 List of spare parts

No spare parts are available for this sensor.

6.5 Transport and storage

The conditions of transport and storage of the sensor match the operating conditions mentioned in this document.

7. Removal from service/dismantling

The product contains electronic components and must be disposed of in accordance with the local regulations.

8. Technical data

8.1 Technical data of Temposonics® RP5

Output							
Analogue	Voltage: 0...10 /10...0/-10...+10/+10...-10 VDC (min. controller load > 5 kΩ) Current: 4(0)...20/20...4(0) mA (min./max. load 0/500 Ω)						
Measured output variables	Position for one or two position magnets Position + speed (without direction) or velocity (with direction) for one position magnet Position for one position magnet + temperature inside the sensor electronics housing						
Measurement parameters							
Position measurement							
Null/Span adjustment	100 % of electrical stroke						
Resolution	16 bit (internal resolution 0.1 μm)						
Update time	Stroke length	≤ 200 mm	≤ 350 mm	≤ 1200 mm	≤ 2400 mm	≤ 4800 mm	≤ 6350 mm
	Update time	0.25 ms	0.333 ms	0.5 ms	1.0 ms	2.0 ms	5.0 ms
Linearity deviation ⁴	< ±0.01 % F.S. (minimum ±50 μm)						
Repeatability	< ±0.001 % F.S. (minimum ±1 μm)						
Hysteresis	< 4 μm typical						
Temperature coefficient	< 30 ppm/K typical						
Speed/velocity measurement							
Range	0.01...10 m/s or 1...400 in./s						
Deviation	≤ 0.05 %						
Resolution	16 bit (minimum 0.01 mm/s)						
Operating conditions							
Operating temperature	-40...+85 °C (-40...+185 °F)						
Humidity	90 % relative humidity, no condensation						
Ingress protection	IP67 (connectors correctly fitted)/IP68 (3 m/3 d) for cable outlet						
Shock test	150 g/11 ms, IEC standard 60068-2-27						
Vibration test	30 g/10...2000 Hz, IEC standard 60068-2-6 (excluding resonant frequencies)						
EMC test	Electromagnetic emission according to EN 61000-6-3						
	Electromagnetic immunity according to EN 61000-6-2						
	The RP5 sensors fulfill the requirements of the EMC directives 2014/30/EU, UKSI 2016 No. 1091 and TR CU 020/2011						
Magnet movement velocity	Magnet slider: Max. 10 m/s; U-magnet: Any; block magnet: Any						
Design/Material							
Sensor electronics housing	Aluminum (painted), zinc die cast						
Sensor profile	Aluminum						
RoHS compliance	The used materials are compliant with the requirements of EU directive 2011/65/EU and EU regulation 2015/863 as well as UKSI 2022 No. 622						
Stroke length	25...6350 mm (1...250 in.)						
Mechanical mounting							
Mounting position	Any						
Mounting instruction	Please consult the technical drawings on page 17						

Technical data "Electrical connection" on [page 67](#)

4/ With position magnet # 251 416-2

Electrical connection	
Connection type	1 × M16 male connectors (6 pin), 1 × M12 male connector (5 pin) or cable outlet
Operating voltage	+12...30 VDC ±20 % (9.6...36 VDC)
Power consumption	< 3.25 W
Dielectric strength	500 VDC (DC ground to machine ground)
Polarity protection	Up to -36 VDC
Overvoltage protection	Up to 36 VDC

8.2 Technical data of Temposonics® RH5

Output							
Analogue	Voltage: 0...10 /10...0/-10...+10/+10...-10 VDC (min. controller load > 5 kΩ) Current: 4(0)...20/20...4(0) mA (min./max. load 0/500 Ω)						
Measured output variables	Position for one or two position magnets Position + speed (without direction) or velocity (with direction) for one position magnet Position for one position magnet + temperature inside the sensor electronics housing						
Measurement parameters							
Position measurement							
Null/Span adjustment	100 % of electrical stroke						
Resolution	16 bit (internal resolution 0.1 μm)						
Update time	Stroke length	≤ 200 mm	≤ 350 mm	≤ 1200 mm	≤ 2400 mm	≤ 4800 mm	≤ 7620 mm
	Update time	0.25 ms	0.333 ms	0.5 ms	1.0 ms	2.0 ms	5.0 ms
Linearity deviation ⁵	< ±0.01 % F.S. (minimum ±50 μm)						
Repeatability	< ±0.001 % F.S. (minimum ±1 μm)						
Hysteresis	< 4 μm typical						
Temperature coefficient	< 30 ppm/K typical						
Speed/velocity measurement							
Range	0.01...10 m/s or 1...400 in./s						
Deviation	≤ 0.05 %						
Resolution	16 bit (minimum 0.01 mm/s)						
Operating conditions							
Operating temperature	-40...+85 °C (-40...+185 °F)						
Humidity	90 % relative humidity, no condensation						
Ingress protection	IP67 (connectors correctly fitted)/IP68 (3 m/3 d) for cable outlet						
Shock test	150 g/11 ms, IEC standard 60068-2-27						
Vibration test	30 g/10...2000 Hz, IEC standard 60068-2-6 (excluding resonant frequencies)/ RH5-J: 15 g / 10...2000 Hz, IEC standard 60068-2-6 (excluding resonant frequencies)						
EMC test	Electromagnetic emission according to EN 61000-6-3						
	Electromagnetic immunity according to EN 61000-6-2 The RH5 sensors fulfill the requirements of the EMC directives 2014/30/EU, UKSI 2016 No. 1091 and TR CU 020/2011						
Operating pressure	350 bar (5,076 psi)/700 bar (10,153 psi) peak (at 10 × 1 min) for sensor rod/RH5-J: 800 bar (11,603 psi)						
Magnet movement velocity	Any						
Design/Material							
Sensor electronics housing	Aluminum (painted), zinc die cast						
Sensor flange	Stainless steel 1.4305 (AISI 303)						
Sensor rod	Stainless steel 1.4306 (AISI 304L)/RH5-J: Stainless steel 1.4301 (AISI 304)						
RoHS compliance	The used materials are compliant with the requirements of EU directive 2011/65/EU and EU regulation 2015/863 as well as UKSI 2022 No. 622						
Stroke length	25...7620 mm (1...300 in.)/RH5-J: 25...5900 mm (1...232 in.)						
Mechanical mounting							
Mounting position	Any						
Mounting instruction	Please consult the technical drawings on page 19 and page 20						

Technical data "Electrical connection" on [page 69](#)

5/ With position magnet # 251 416-2

Electrical connection	
Connection type	1 × M16 male connector (6 pin), 1 × M12 male connector (5 pin) or cable outlet
Operating voltage	+12...30 VDC ±20 % (9.6...36 VDC)
Power consumption	< 3.25 W
Dielectric strength	500 VDC (DC ground to machine ground)
Polarity protection	Up to -36 VDC
Overvoltage protection	Up to 36 VDC

8.3 Technical data of Temposonics® RM5

Output							
Analogue	Voltage: 0...10 /10...0/-10...+10/+10...-10 VDC (min. controller load > 5 kΩ) Current: 4(0)...20/20...4(0) mA (min./max. load 0/500 Ω)						
Measured output variables	Position for one or two position magnets Position + speed (without direction) or velocity (with direction) for one position magnet Position for one position magnet + temperature inside the sensor electronics housing						
Measurement parameters							
Position measurement							
Null/Span adjustment	100 % of electrical stroke						
Resolution	16 bit (internal resolution 0.1 μm)						
Update time	Stroke length	≤ 200 mm	≤ 350 mm	≤ 1200 mm	≤ 2400 mm	≤ 4800 mm	≤ 7615 mm
	Update time	0.25 ms	0.333 ms	0.5 ms	1.0 ms	2.0 ms	5.0 ms
Linearity deviation ⁶	< ±0.01 % F.S. (minimum ±50 μm)						
Repeatability	< ±0.001 % F.S. (minimum ±1 μm)						
Hysteresis	< 4 μm typical						
Temperature coefficient	< 30 ppm/K typical						
Speed/velocity measurement							
Range	0.01...10 m/s or 1...400 in./s						
Deviation	≤ 0.05 %						
Resolution	16 bit (minimum 0.01 mm/s)						
Operating conditions							
Operating temperature	-40...+85 °C (-40...+185 °F)						
Humidity	100 % relative humidity, no condensation						
Ingress protection	IP68 (3 m/180 d)/IP69						
Shock test	100 g/6 ms, IEC standard 60068-2-27						
Vibration test	10 g/10...2000 Hz, IEC 60068-2-6 (excluding resonant frequencies)						
EMC test	Electromagnetic emission according to EN 61000-6-3						
	Electromagnetic immunity according to EN 61000-6-2						
	The RM5 sensors fulfill the requirements of the EMC directives 2014/30/EU, UKSI 2016 No. 1091 and TR CU 020/2011						
Operating pressure	350 bar (5076 psi)/700 bar (10,153 psi) peak (at 10 × 1 min) for sensor rod						
Magnet movement velocity	Any						
Design/Material							
Sensor electronics housing	Stainless steel 1.4404 (AISI 316L)						
Sensor flange	Stainless steel 1.4404 (AISI 316L)						
Sensor rod	Stainless steel 1.4404 (AISI 316L)						
RoHS compliance	The used materials are compliant with the requirements of EU directive 2011/65/EU and EU regulation 2015/863 as well as UKSI 2022 No. 622						
Stroke length	25...7615 mm (1...299.8 in.)						
Mechanical mounting							
Mounting position	Any						
Mounting instruction	Please consult the technical drawing on page 22						

Technical data "Electrical connection" on [page 71](#)

Electrical connection	
Connection type	Cable outlet
Operating voltage	+12...30 VDC \pm 20 % (9.6...36 VDC)
Power consumption	< 3.25 W
Dielectric strength	500 VDC (DC ground to machine ground)
Polarity protection	Up to -36 VDC
Overvoltage protection	Up to 36 VDC

8.4 Technical data of Temposonics® RFV

Output									
Analog	Voltage: 0...10 /10...0/-10...+10/+10...-10 VDC (min. controller load > 5 kΩ) Current: 4(0)...20/20...4(0) mA (min./max. load 0/500 Ω)								
Measured output variables	Position for one or two position magnets Position + speed (without direction) or velocity (with direction) for one position magnet Position for one position magnet + temperature inside the sensor electronics housing								
Measurement parameters									
Position measurement									
Null/Span adjustment	100 % of electrical stroke								
Resolution	16 bit (internal resolution 0.1 μm)								
Update time	Stroke length	≤ 200 mm	≤ 350 mm	≤ 1200 mm	≤ 2400 mm	≤ 4800 mm	≤ 7620 mm	≤ 10,000 mm	≤ 20,000 mm
	Update time	0.25 ms	0.333 ms	0.5 ms	1.0 ms	2.0 ms	5.0 ms	7.5 ms	15.0 ms
Linearity deviation ⁷	< ±0.02 % F.S. (minimum ±100 μm)								
Repeatability	< ±0.001 % F.S. (minimum ±2,5 μm) typical								
Hysteresis	< 4 μm typical								
Temperature coefficient	< 30 ppm/K typical								
Speed/velocity measurement									
Range	0.01...10 m/s or 1...400 in./s								
Deviation	≤ 0.05 %								
Resolution	16 bit (minimum 0.01 mm/s)								
Operating conditions									
Operating temperature	-40...+85 °C (-40...+185 °F)								
Humidity	90 % relative humidity, no condensation								
Ingress protection	IP30 (IP65 rating only for professional mounted guide pipe and if mating connectors are correctly fitted)								
Shock test	100 g/6 ms IEC standard 60068-2-27								
Vibration test	5 g/10...2000 Hz, IEC standard 60068-2-6 (excluding resonant frequencies)								
EMC test	Electromagnetic emission according to EN 61000-6-3 Electromagnetic immunity according to EN 61000-6-2 The RFV sensors fulfill the requirements of the EMC directives 2014/30/EU, UKSI 2016 No. 1091 and TR CU 020/2011 under the condition of an EMC compliant installation ⁸								
Magnet movement velocity	Any								
Design/Material									
Sensor electronics housing	Aluminum (painted), zinc die cast								
Sensor flange	Stainless steel 1.4305 (AISI 303)								
Sensor rod	Stainless steel conduit with PTFE coating								
RoHS compliance	The used materials are compliant with the requirements of EU directive 2011/65/EU and EU regulation 2015/863 as well as UKSI 2022 No. 622								
Stroke length	150...20,000 mm (6...787 in.)								
Mechanical mounting									
Mounting position	Any								
Mounting instruction	Please consult the technical drawings on page 24 and page 25								

Technical data "Electrical connection" on [page 73](#)

7/ With position magnet # 251 416-2

8/ The flexible sensor element must be mounted in an appropriately shielded environment

Electrical connection	
Connection type	1 × M16 male connector (6 pin) or 1 × M12 male connector (5 pin) or cable outlet
Operating voltage	+12...30 VDC ±20 % (9.6...36 VDC)
Power consumption	< 3.25 W
Dielectric strength	500 VDC (DC ground to machine ground)
Polarity protection	Up to -36 VDC
Overvoltage protection	Up to 36 VDC

8.5 Technical data of Temposonics® RDV

Output							
Analogue	Voltage: 0...10 /10...0/-10...+10/+10...-10 VDC (min. controller load > 5 kΩ) Current: 4(0)...20/20...4(0) mA (min./max. load 0/500 Ω)						
Measured output variables	Position for one or two position magnets Position + speed (without direction) or velocity (with direction) for one position magnet Position for one position magnet + temperature inside the sensor electronics housing						
Measurement parameters							
Position measurement							
Null/Span adjustment	100 % of electrical stroke						
Resolution	16 bit (internal resolution 0.1 μm)						
Update time	Stroke length	≤ 200 mm	≤ 350 mm	≤ 1200 mm	≤ 2400 mm	≤ 4800 mm	≤ 5080 mm
	Update time	0.25 ms	0.333 ms	0.5 ms	1.0 ms	2.0 ms	2.2 ms
Linearity deviation ^{9,10}	Stroke length	≤ 500 mm	> 500 mm				
	Linearity deviation	≤ ±50 μm	< ±0.01 % F.S.				
Repeatability	< ±0.001 % F.S. (minimum ±1 μm)						
Hysteresis	< 4 μm typical						
Temperature coefficient	< 30 ppm/K typical						
Speed/velocity measurement							
Range	0.01...10 m/s or 1...400 in./s						
Deviation	≤ 0.05 %						
Resolution	16 bit (minimum 0.01 mm/s)						
Operating conditions							
Operating temperature	-40...+85 °C (-40...+185 °F)						
Humidity	90 % relative humidity, no condensation						
Ingress protection	Sensor electronics: IP67 (with professional mounted housing and connectors) Measuring rod with connecting cable for side cable entry: IP65 Measuring rod with single wires and flat connector with bottom cable entry: IP30						
Shock test	100 g/11 ms, IEC standard 60068-2-27						
Vibration test	10 g/10...2000 Hz, IEC standard 60068-2-6 (excluding resonant frequencies)						
EMC test	Electromagnetic emission according to EN 61000-6-3						
	Electromagnetic immunity according to EN 61000-6-2 The RDV sensors fulfill the requirements of the EMC directives 2014/30/EU, UKSI 2016 No. 1091 and TR CU 020/2011 under the condition of an EMC compliant installation ¹¹						
Operating pressure	350 bar (5076 psi)/700 bar (10,153 psi) peak (at 10 × 1 min) for sensor rod						
Magnet movement velocity	Any						
Design/Material							
Sensor electronics housing	Aluminum (painted), zinc die cast						
Sensor rod with flange	Stainless steel 1.4301 (AISI 304)						
RoHS compliance	The used materials are compliant with the requirements of EU directive 2011/65/EU and EU regulation 2015/863 as well as UKSI 2022 No. 622						
Stroke length	25...2540 mm (1...100 in.) for pressure-fit flange »S«						
	25...5080 mm (1...200 in.) for all threaded flanges						

Technical data “Mechanical mounting” and “Electrical connection” on [page 75](#)

^{9/} With position magnet # 251 416-2

^{10/} For rod style »S« the linearity deviation can be higher in the first 30 mm (1.2 in.) of stroke length

^{11/} The cable between the sensor element and the sensor electronics housing must be mounted in an appropriately shielded environment

Mechanical mounting	
Mounting position	Any
Mounting instruction	Please consult the technical drawings on page 29 , page 30 and page 31
Electrical connection	
Connection type	1 × M16 male connector (6 pin), 1 × M12 male connector (5 pin) or cable outlet
Operating voltage	+12...30 VDC ±20 % (9.6...36 VDC)
Power consumption	< 3.25 W
Dielectric strength	500 VDC (DC ground to machine ground)
Polarity protection	Up to -36 VDC
Overvoltage protection	Up to 36 VDC

9. Appendix I

Safety declaration

Dear Customer,

If you return one or several sensors for checking or repair, we need you to sign a safety declaration. The purpose of this declaration is to ensure that the returned items do not contain residues of harmful substances and/or that people handling these items will not be in danger.

Temposonics order code: _____ Sensor model(s): _____

Serial number(s): _____ Stroke length(s): _____

The sensor has been in contact with the following materials:

Do not specify chemical formulas.
 Please include safety data sheets of the substances, if applicable.

In the event of suspected penetration of substances into the sensor,
 consult Temposonics to determine measures to be taken before
 shipment.

Short description of malfunction:

Corporate information

Company: _____

Address: _____

Contact partner

Phone: _____

Fax: _____

Email: _____

We hereby certify that the measuring equipment has been cleaned and neutralized.
 Equipment handling is safe. Personnel exposure to health risks during transport and repair is excluded.

Stamp

Signature

Date

Temposonics, LLC Tel. +1 919 677-0100
 3001 Sheldon Drive Fax +1 (919) 677-0200
 Cary, N.C. 27513 info.us@temposonics.com
 United States www.temposonics.com

Temposonics GmbH & Co.KG Tel. +49 2351/95 87-0
 Auf dem Schüffel 9 Fax. +49 2351/56 49 1
 58513 Lüdenscheid info.de@temposonics.com
 Germany www.temposonics.com

10. Appendix II

CYLINDER PORT DETAILS

PORT DETAIL (PD) FOR RH5-S:

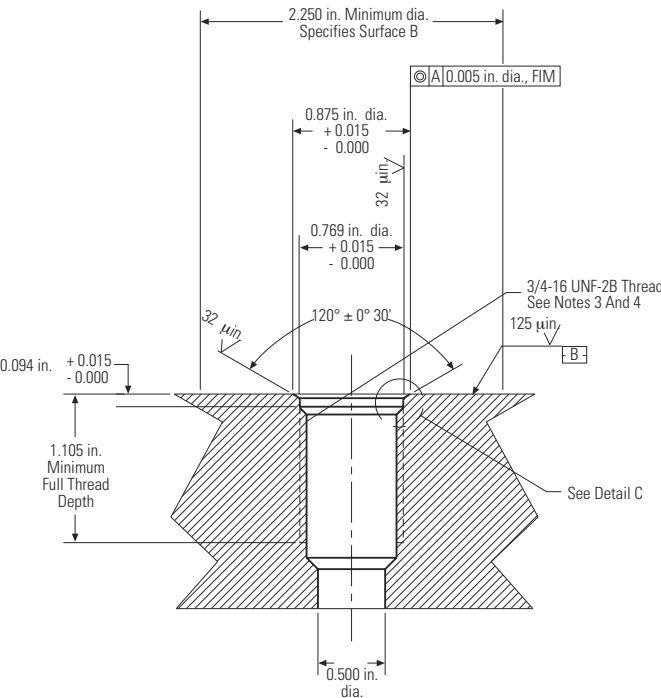

- NOTES:**
1. Dimensions and tolerances based on ANSI Y14.5-1982.
 2. Temposonics has extracted all pertinent information from MS33649 to generate this document.
 3. PD must be square with surface B within 0.005 FIM across 2.250 dia minimum.
 4. PD must be concentric with 2.250 dia within 0.030 FIM and with 0.769 dia within 0.005 FIM.
 5. Surface texture ANSI B46.1-1978
 6. Use O-ring part number 560315 for correct sealing.
 7. The thread design shall have sufficient threads to meet strength requirements of material used.
 8. Finish counter-bore shall be free from longitudinal and spiral tool marks. Annular tool marks up to 32 microinches maximum will be permissible.

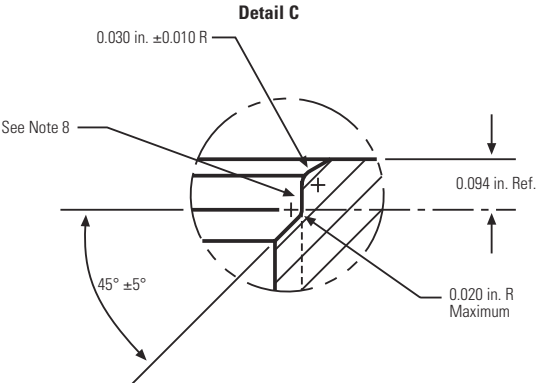

PORT DETAIL (PD) FOR RH5-T:

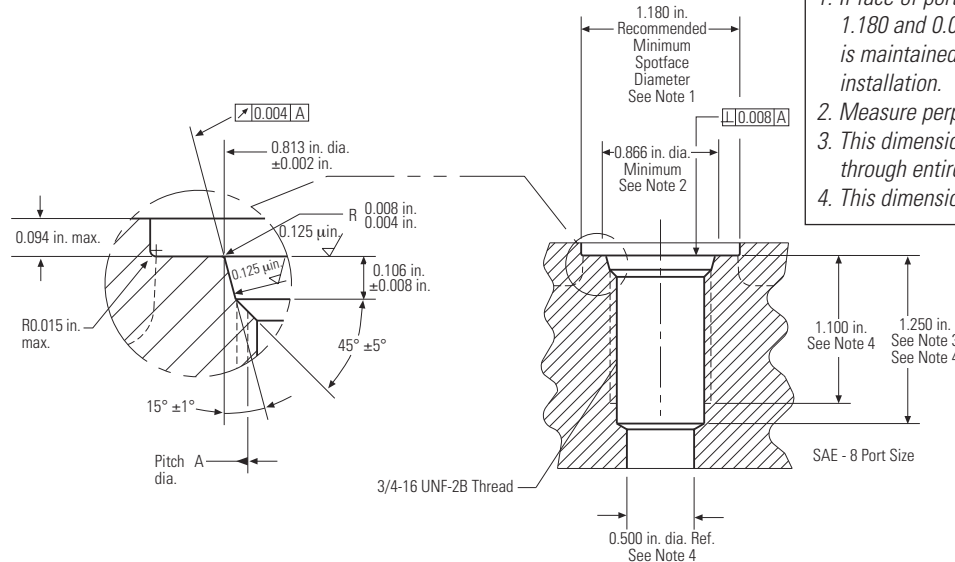

- NOTES:**
1. If face of port is on a machined surface, dimensions 1.180 and 0.094 need not apply as long as R0.008/0.004 is maintained to avoid damage to the O-ring during installation.
 2. Measure perpendicularity to A at this diameter.
 3. This dimension applies when tap drill cannot pass through entire boss.
 4. This dimension does not conform to SAE J1926/1.

11. Glossary

A

Analog output

For a sensor with analog output, the measured value is output as an analog voltage signal or current signal.

D

Differential

For differential measurement, the distance between the two position magnets is output as a value.
(→ multi-position measurement)

M

Max. speed or velocity value

For speed or velocity, the output value generated is scaled based on the maximum speed or velocity value indicated in the order code.

Measuring direction

- Forward: Values increasing from sensor electronics housing to rod end/profile end
- Reverse: Values decreasing from sensor electronics housing to rod end/profile end

Multi-position measurement

During the measurement cycle, the positions of every magnet on the sensor are simultaneously reported. The velocity or speed is continuously calculated based on these changing position values as the magnets are moved.

O

Over range output mode

When enabled this mode allows the position output values to continue to increase or decrease when the magnet travels beyond the active stroke range.

R

Resolution

The sensor precisely measures time to provide the position measurement. For the analog output the measured time value is converted into an analog voltage signal or current signal using a high-performance Digital to Analog Converter (DAC) having 16 bits of resolution.

S

Speed

The output value for speed indicates how fast the position magnet is being moved, independent of the measuring direction. (→ Velocity)

T

Temperature inside the sensor electronics housing

The temperature inside the sensor electronics housing is reported as an analog voltage signal or current signal. For each output range, the 0 % output value has the factory default setpoint at -40 °C, and the 100 % output value has the default setpoint at +100 °C.

Note: A dedicated temperature chip is used for the output signal and its values may vary from those reported on the TempoLink® application screen.

V

Velocity

The output value for velocity indicates how fast the position magnet is being moved, and in which direction. (→ Speed)

UNITED STATES
Temposonics, LLC
Americas & APAC Region
3001 Sheldon Drive
Cary, N.C. 27513
Phone: +1 919 677-0100
E-mail: info.us@temposonics.com

GERMANY
Temposonics
GmbH & Co. KG
EMEA Region & India
Auf dem Schüffel 9
58513 Lüdenscheid
Phone: +49 2351 9587-0
E-mail: info.de@temposonics.com

ITALY
Branch Office
Phone: +39 030 988 3819
E-mail: info.it@temposonics.com

FRANCE
Branch Office
Phone: +33 6 14 060 728
E-mail: info.fr@temposonics.com

UK
Branch Office
Phone: +44 79 21 83 05 86
E-mail: info.uk@temposonics.com

SCANDINAVIA
Branch Office
Phone: +46 70 29 91 281
E-mail: info.sca@temposonics.com

CHINA
Branch Office
Phone: +86 21 3405 7850
E-mail: info.cn@temposonics.com

JAPAN
Branch Office
Phone: +81 3 6416 1063
E-mail: info.jp@temposonics.com

Document Part Number:
552063 Revision E (EN) 09/2023



temposonics.com