

Temposonics®

Magnetostrictive Linear Position Sensors

TH Analog SIL 2 Capable Data Sheet

- ATEX / IECEx / CEC / NEC / EAC Ex / KCs certified / Japanese approval
- Continuous operation under harsh industrial conditions
- Flameproof / Explosionproof / Increased safety



MEASURING TECHNOLOGY

The absolute, linear position sensors provided by MTS Sensors rely on the company's proprietary Temposonics® magnetostrictive technology, which can determine position with a high level of precision and robustness. Each Temposonics® position sensor consists of a ferromagnetic waveguide, a position magnet, a strain pulse converter and supporting electronics. The magnet, connected to the object in motion in the application, generates a magnetic field at its location on the waveguide. A short current pulse is applied to the waveguide. This creates a momentary radial magnetic field and torsional strain on the waveguide. The momentary interaction of the magnetic fields releases a torsional strain pulse that propagates the length of the waveguide. When the ultrasonic wave reaches the end of the waveguide it is converted into an electrical signal. Since the speed of the ultrasonic wave in the waveguide is precisely known, the time required to receive the return signal can be converted into a linear position measurement with both high accuracy and repeatability.

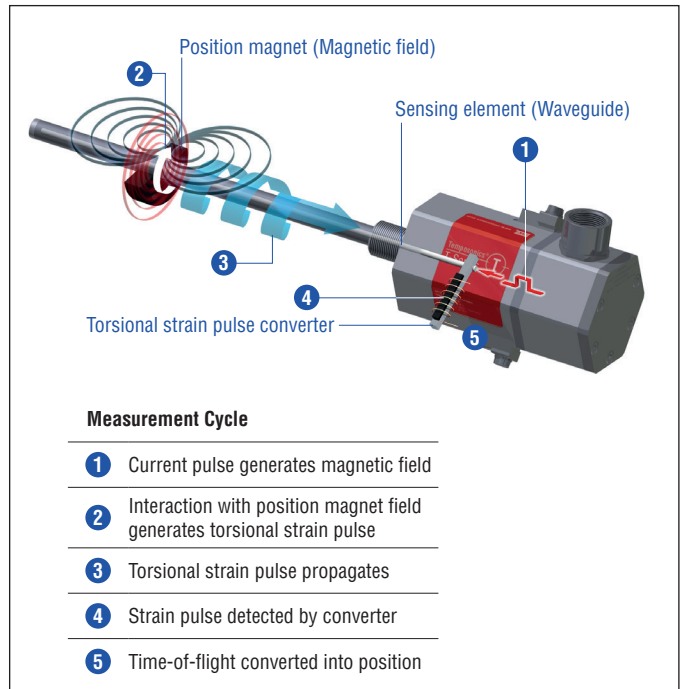

Fig. 1: Time-of-flight based magnetostrictive position sensing principle

TH SENSOR

Robust, non-contact and wear free, the Temposonics® linear position sensors provide best durability and accurate position measurement solutions in harsh industrial environments. The position measurement accuracy is tightly controlled by the quality of the waveguide which is manufactured by MTS Sensors. The position magnet is mounted on the moving machine part and travels contactlessly over the sensor rod with the built-in waveguide.

The T-series TH sensor is extremely robust and ideal for continuous operation under harsh industrial conditions. The T-Series sensors are certified for hazardous areas in Zone 0/1, Zone 1, Zone 2, Zone 21 and Zone 22 for the European (ATEX), the global (IECEX), the Russian (EAC Ex), the South Korean (KCs) and the Japanese market. Further certifications are Class I, II, III, Division 1, Division 2 for Canada (CEC) and USA (NEC). The T-Series sensors meet the requirements for SIL 2. The sensor electronics housing contains the active signal conditioning and a complete integrated electronics interface. The sensor rod is capable of withstanding high pressures such as those found in hydraulic cylinders. Furthermore the sensor is also suitable for petro chemical plants and caustic environments.



Fig. 2: Typical application: Tank systems

TECHNICAL DATA

Output	
Current	4...20 mA, 20...4 mA (minimum / maximum load 0 / 500 Ω)
Measured value	Position
Measurement parameters	
Resolution	16 bit; 0.0015 % (minimum 1 μm) ¹
Cycle time	2.0 ms
Linearity ²	< ±0.01 % F.S. (minimum ±50 μm)
Repeatability	< ±0.001 % F.S. (minimum ±2.5 μm) typical
Hysteresis	< 4 μm typical
Temperature coefficient	< 30 ppm/K typical
Operating conditions	
Operating temperature	Version E: -40...+80 °C (-40...+176 °F) Version D, G: -40...+85 °C (-40...+185 °F)
Humidity	90 % relative humidity, no condensation
Ingress protection	Version D, G and E: IP66 / IP67 (if properly connected by means that support IP66 / IP67 (pipe, gland, etc.)) Version N: IP66, IP67, IP68, IP69K, NEMA 4X, depending on cable gland
Shock test	100 g (single shock), IEC standard 60068-2-27
Vibration test	15 g / 10...2000 Hz, IEC standard 60068-2-6 (resonance frequencies excluded)
EMC test	Electromagnetic emission according to IEC/EN 61326-1 (Class B) Electromagnetic immunity according to IEC/EN 61326-3-2 (Class B) The sensor meets the requirements of the EU directives and is marked with CE
Operating pressure	350 bar static (5076 psi static)
Magnet movement velocity ³	Any
Design / Material	
Sensor electronics housing	Stainless steel 1.4305 (AISI 303); option: Stainless steel 1.4404 (AISI 316L)
Flange	See "Table 1: TH rod sensor threaded flange type references" on page 7
Sensor rod	Stainless steel 1.4306 (AISI 304L); option: Stainless steel 1.4404 (AISI 316L)
Stroke length	25...1500 mm (1...60 in.)
Mechanical mounting	
Mounting position	Any orientation
Mounting instruction	Please consult the technical drawings and the operation manual (document number: 551513)
Electrical connection	
Connection type	T-Series terminal
Operating voltage	+24 VDC (-15 / +20 %)
Ripple	≤ 0.28 V _{pp}
Current consumption	100 mA typical
Dielectric strength	700 VDC (DC ground to machine ground)
Polarity protection	Up to -30 VDC
Overvoltage protection	Up to 36 VDC

1/ The internal digital value is transferred via a 16 bit D/A converter into a proportional, analog current signal

2/ With position magnet # 201 542-2

3/ If there is contact between the moving magnet (including the magnet holder) and the sensor rod, make sure that the maximum speed of the moving magnet is ≤ 1 m/s (Safety requirement due to ESD [Electro Static Discharge])

CERTIFICATIONS

Certification required	Version E	Version D	Version G	Version N
IECEX / ATEX (IECEX: Global market; ATEX: Europe)	Ex db eb IIC T4 Ga/Gb Ex tb IIIC T130°C Ga/Db Zone 0/1, Zone 21 -40 °C ≤ Ta ≤ 80 °C	Ex db IIC T4 Ga/Gb Ex tb IIIC T130°C Ga/Db Zone 0/1, Zone 21 -40 °C ≤ Ta ≤ 85 °C	Ex db IIC T4 Ga/Gb Ex tb IIIC T130°C Ga/Db Zone 0/1, Zone 21 -40 °C ≤ Ta ≤ 85 °C	No hazardous area approval
NEC (USA)	Non-incendive Class I Div. 2 Groups A, B, C, D T4 Class II/III Div. 2 Groups E, F, G -40 °C ≤ Ta ≤ 80 °C Non-sparking Class I Zone 2 AEx nA IIC T4 Gc Class II/III Zone 22 AEx tc IIIC T130°C Dc -40 °C ≤ Ta ≤ 80 °C	—	Explosionproof Class I Div. 1 Groups A, B, C, D T4 Class II/III Div. 1 Groups E, F, G T130°C -40 °C ≤ Ta ≤ 85 °C Flameproof Class I Zone 0/1 AEx d IIC T4 Class II/III Zone 21 AEx tb IIIC T130°C -40 °C ≤ Ta ≤ 85 °C	No hazardous area approval
CEC (Canada)	Non-incendive Class I Div. 2 Groups A, B, C, D T4 Class II/III Div. 2 Groups E, F, G -40 °C ≤ Ta ≤ 80 °C Non-sparking Class I Zone 2 Ex nA IIC T4 Gc Class II/III Zone 22 Ex tc IIIC T130°C Dc -40 °C ≤ Ta ≤ 80 °C	—	Explosionproof Class I Div. 1 Groups B, C, D T4 Class II/III Div. 1 Groups E, F, G T130°C -40 °C ≤ Ta ≤ 85 °C Flameproof Class I Zone 0/1 Ex d IIC T4 Ga/Gb Class II/III Zone 21 Ex tb IIIC T130°C Db -40 °C ≤ Ta ≤ 85 °C	No hazardous area approval
EAC Ex (Russian market)	Ga/Gb Ex db eb IIC T4 X Da/Db Ex tb IIIC T130°C X Zone 0/1, Zone 21 -40 °C ≤ Ta ≤ 80 °C	Ga/Gb Ex db IIC T4 X Da/Db Ex tb IIIC T130°C X Zone 0/1, Zone 21 -40 °C ≤ Ta ≤ 85 °C	Ga/Gb Ex db IIC T4 X Da/Db Ex tb IIIC T130°C X Zone 0/1, Zone 21 -40 °C ≤ Ta ≤ 85 °C	No hazardous area approval
KCs (South Korea)	Ex d e IIC T4 Ex tb IIIC T130°C Zone 0/1; Zone 21 -40 °C ≤ Ta ≤ 80 °C	Ex d IIC T4 Ex tb IIIC T130°C Zone 0/1; Zone 21 -40 °C ≤ Ta ≤ 85 °C	Ex d IIC T4 Ex tb IIIC T130°C Zone 0/1, Zone 21 -40 °C ≤ Ta ≤ 85 °C	No hazardous area approval
Japanese approval	Ex d e IIC T4 Ga/Gb Ex t IIIC T130°C Db Zone 0/1, Zone 21 -40 °C ≤ Ta ≤ 80 °C	Ex d IIC T4 Ga/Gb Ex t IIIC T130°C Db Zone 0/1, Zone 21 -40 °C ≤ Ta ≤ 85 °C	Ex d IIC T4 Ga/Gb Ex t IIIC T130°C Db Zone 0/1, Zone 21 -40 °C ≤ Ta ≤ 85 °C	No hazardous area approval

Fig. 3: Certifications

THE SAFETY FUNCTION

The T-Series safety sensor will continuously output a position signal proportional to the magnet position, and the internal diagnostic function will check safety relevant parameters within the hardware. The sensor will report an output error signal in the event of a failure. The electronic control unit (ECU) receives the provided signals. In the event of a failure, the ECU must react in an appropriate manner in order to manage the emergency function. The system will shut off or operate in emergency mode. Refer to the SIL 2 safety manual (document number: [551504](#)) for more in-depth information on SIL 2.

T-Series (SIL 2: Analog Safety) IEC 61508	
Safety Level	SIL 2
Device type	B
MTTF _d	100 years @ 60 °C 44 years @ 80 °C
PFD _{avg}	3.49E-04 @ 60 °C 9.85E-04 @ 80 °C
Diagnostic Response Time (Fail Detection Time)	25 ms (max) 1 sec for CRC fault detection
% of SIL 2 range for PFD	3.5 % @ 60 °C 9.9 % @ 80 °C
Hardware Fault Tolerance (HFT)	0
Useful lifetime	50 years @ 60 °C 18 years @ 80 °C
Device @ 1 % accuracy (60 °C / 80 °C / 85 °C)	SFF 93.6 %

Fig. 4: Sensor parameters TH SIL 2

TECHNICAL DRAWINGS

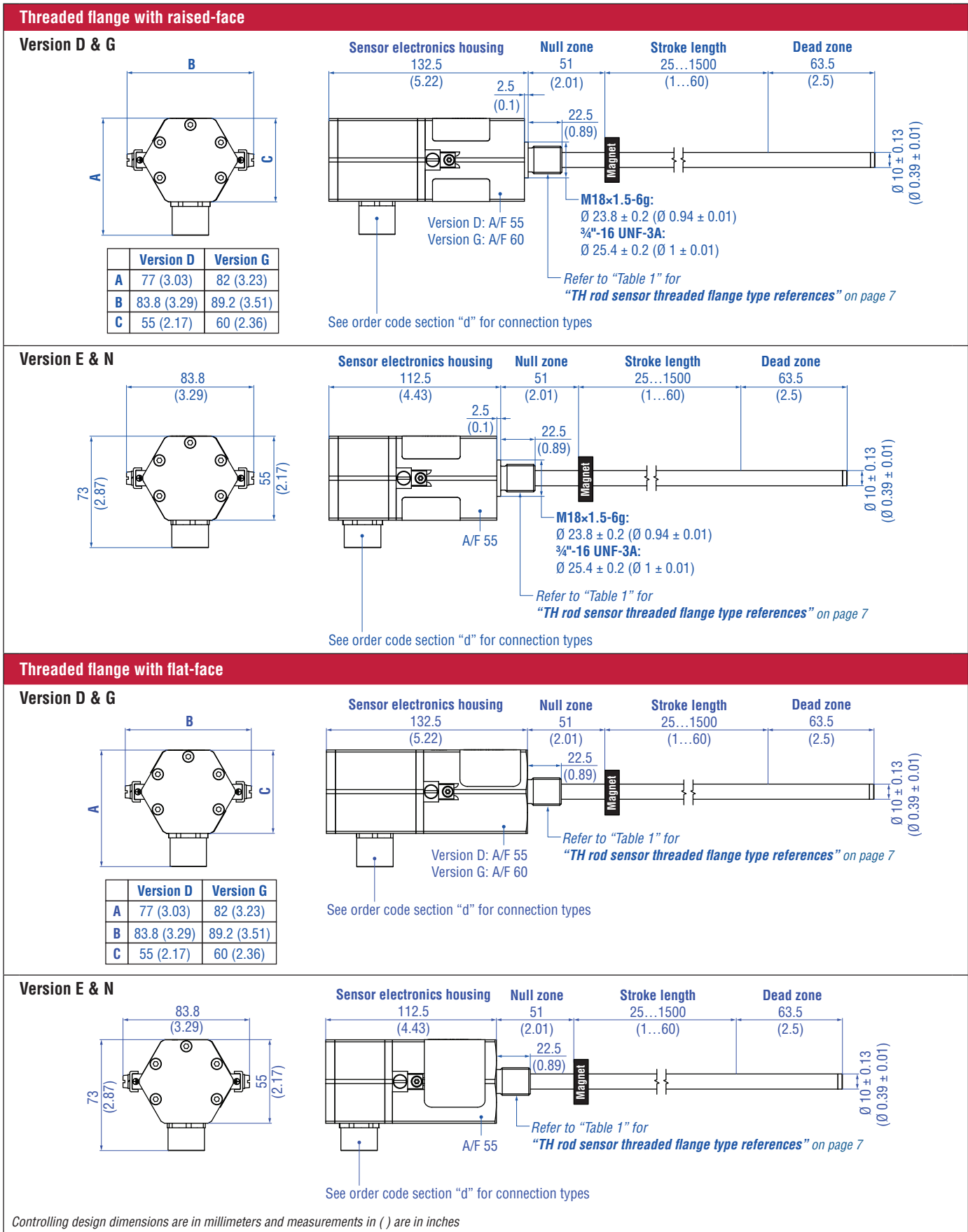

Fig. 5: Tempsonics® TH with ring magnet

CONNECTION OPTIONS

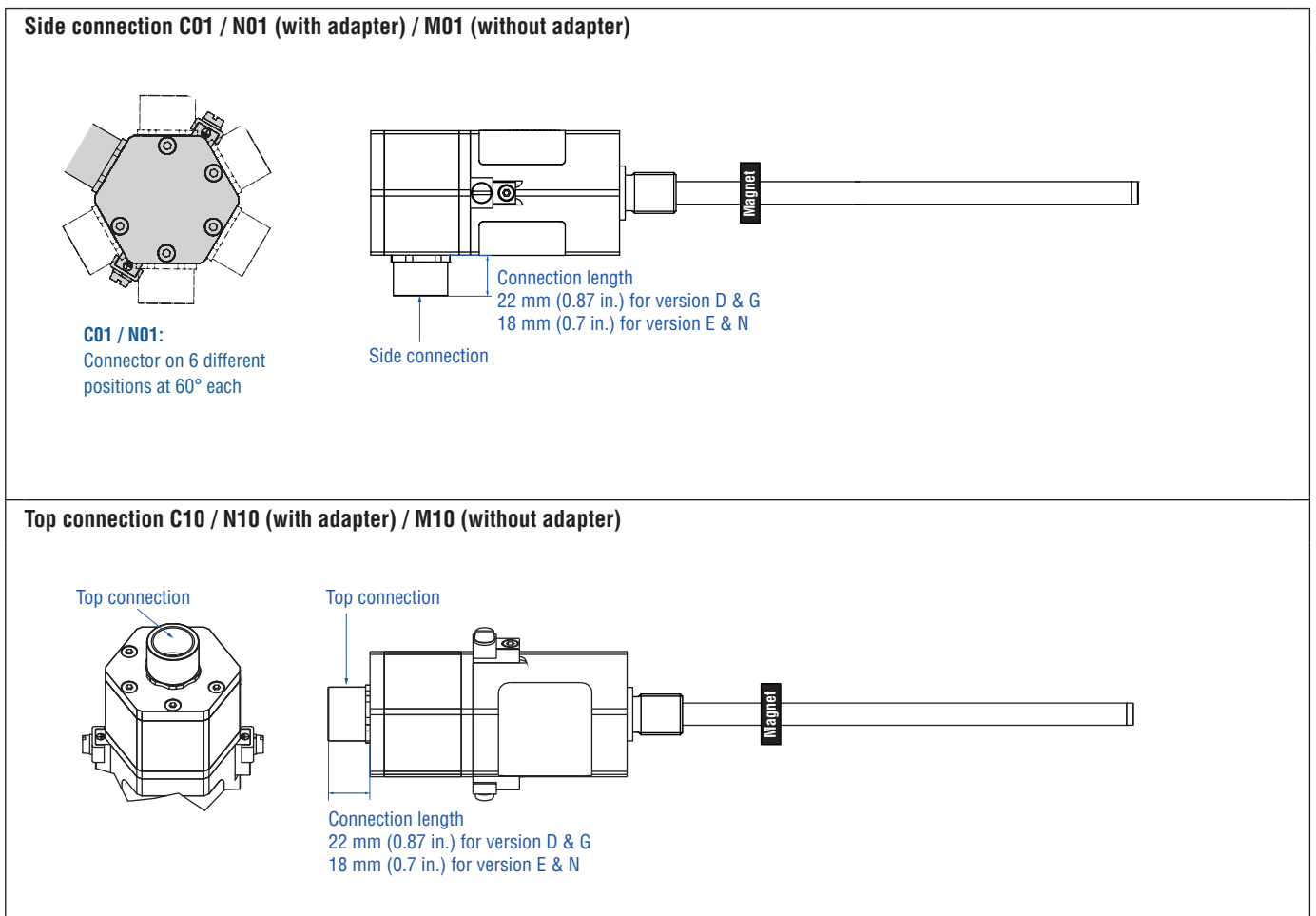

Fig. 6: Temposonics® TH connection options

Threaded flange type	Description	Threaded flange
F	Threaded flange with flat-face Stainless steel 1.4404 (AISI 316L)	¾"-16 UNF-3A
G	Threaded flange with raised-face Stainless steel 1.4404 (AISI 316L)	¾"-16 UNF-3A
M	Threaded flange with flat-face Stainless steel 1.4305 (AISI 303)	M18×1.5-6g
N	Threaded flange with raised-face Stainless steel 1.4305 (AISI 303)	M18×1.5-6g
S	Threaded flange with flat-face Stainless steel 1.4305 (AISI 303)	¾"-16 UNF-3A
T	Threaded flange with raised-face Stainless steel 1.4305 (AISI 303)	¾"-16 UNF-3A
W	Threaded flange with flat-face Stainless steel 1.4404 (AISI 316L)	M18×1.5-6g

Table 1: TH rod sensor threaded flange type references

ZONE CLASSIFICATION

Version D & G (example: Threaded flange with raised-face)
Flameproof (explosionproof) housing with flameproof (explosionproof) connection chamber
Version D: ATEX / IECEx / EAC Ex / KCs / Japanese Approval
Version G: ATEX / IECEx / CEC / NEC / EAC Ex / KCs / Japanese Approval

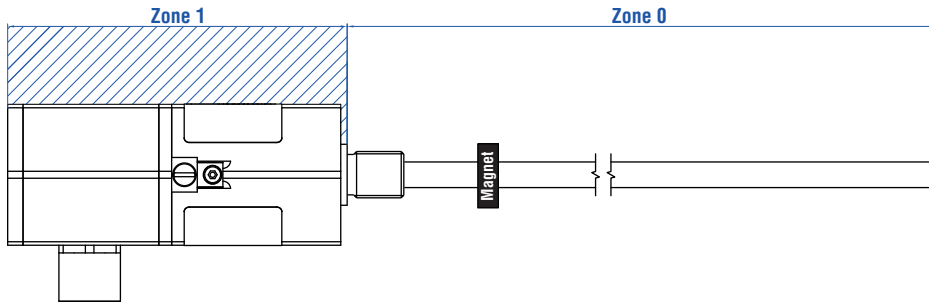

Version E (example: Threaded flange with raised-face)
Flameproof housing with increased safety connection chamber
ATEX / IECEx / CEC / NEC / EAC Ex / KCs / Japanese Approval

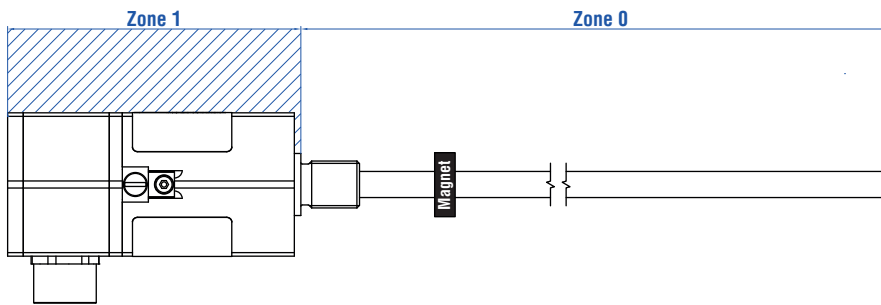

Fig. 7: Temposonics® TH Zone classification

NOTICE

Seal sensor according to ingress protection IP67 between Zone 0 and Zone 1.

CONNECTOR WIRING

Version D & G suitable for connection types: C01, C10, N01, N10		
Signal + power supply		
Terminal	Pin	Function
	1	Output
	2	DC Ground
	3	Not connected
	4	Not connected
	5	+24 VDC (-15 / +20 %)
	6	DC Ground (0 V)
	7	Cable shield

Fig. 8: TH (version D & G) wiring diagram (2.5 mm² conductor)

Version E & N suitable for connection types: C01, C10, M01, M10, N01, N10		
Signal + power supply		
Terminal	Pin	Function
	1	Output
	2	DC Ground
	3	Not connected
	4	Not connected
	5	+24 VDC (-15 / +20 %)
	6	DC Ground (0 V)
	7	Cable shield

Fig. 9: TH (version E & N) wiring diagram (1.5 mm² conductor)

FREQUENTLY ORDERED ACCESSORIES – Additional options available in our [Accessories Guide](#)  [551444](#)

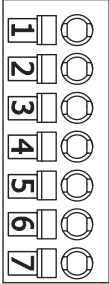
Position magnet

			
<p>Ring magnet OD33 Part no. 201 542-2</p>	<p>Ring magnet OD25.4 Part no. 400 533</p>	<p>U-magnet OD33 Part no. 251 416-2</p>	<p>U-magnet OD63.5 Part no. 201 553</p>
<p>Material: PA ferrite GF20 Weight: Approx. 14 g Surface pressure: Max. 40 N/mm² Fastening torque for M4 screws: 1 Nm Operating temperature: -40...+105 °C (-40...+221 °F)</p>	<p>Material: PA ferrite Weight: Approx. 10 g Surface pressure: Max. 40 N/mm² Operating temperature: -40...+105 °C (-40...+221 °F)</p>	<p>Material: PA ferrite GF20 Weight: Approx. 11 g Surface pressure: Max. 40 N/mm² Fastening torque for M4 screws: 1 Nm Operating temperature: -40...+105 °C (-40...+221 °F)</p>	<p>Material: PA 66-GF30, magnets compound-filled Weight: Approx. 26 g Surface pressure: 20 N/mm² Fastening torque for M4 screws: 1 Nm Operating temperature: -40...+75 °C (-40...+167 °F)</p>

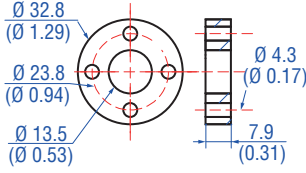
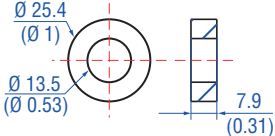
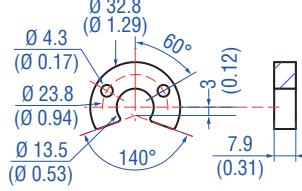
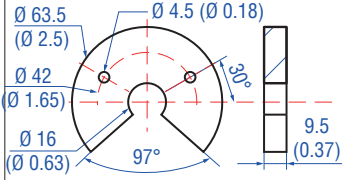
Magnet spacer **Float⁴**

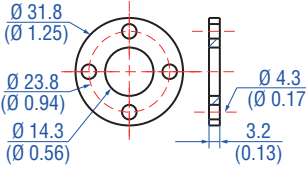
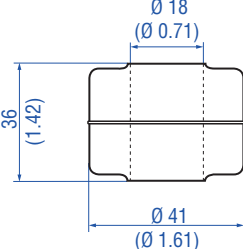
	
<p>Magnet spacer Part no. 400 633</p>	<p>Float Part no. 200 938-2</p>
<p>Material: Aluminum Weight: Approx. 5 g Surface pressure: Max. 20 N/mm² Fastening torque for M4 screws: 1 Nm</p>	<p>Material: Stainless steel (AISI 316L) Weight offset: Yes Pressure: 8.6 bar (125 psi) Magnet offset: No Specific gravity: Max. 0.74 Operating temperature: -40...+125 °C (-40...+257 °F)</p>

Controlling design dimensions are in millimeters and measurements in () are in inches

- 4/
- Be sure that the float specific gravity is at least 0.05 less than that of the measured liquid as a safety margin at ambient temperature
 - For interface measurement: A minimum of 0.05 specific gravity differential is required between the upper and lower liquids

- When the magnet is not shown, the magnet is positioned at the center line of float
- An offset weight is installed in the float to bias or tilt the float installed on the sensor tube. So the float remains in contact with the sensor tube at all times and guarantees permanent potential equalization of the float. The offset is required for installations that must conform to hazardous location standards

Stop collar Optional installation hardware O-rings

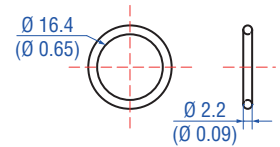
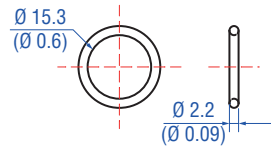
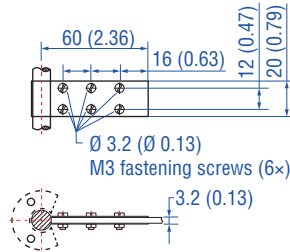
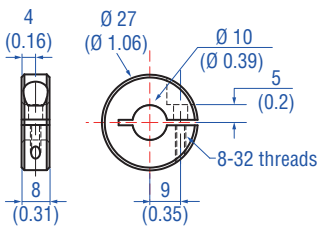

Stop collar
Part no. 560 777

Provides end of stroke stops for float
Material: Stainless steel 1.4301 (AISI 304)
Weight: Approx. 30 g
Hex key 3/64" required

Fixing clip for rod with Ø 10 mm
Part no. 561 481

Application: Used to secure sensor rods (Ø 10 mm (Ø 0.39 in.)) when using an U-magnet or block magnet
Material: Brass, non-magnetic

O-ring for threaded flange
M18x1.5-6g
Part no. 401 133

Material: Fluoroelastomer
Durometer: 75 ± 5 Shore A
Operating temperature: -40...+204 °C (-40...+400 °F)

O-ring for threaded flange
3/4"-16 UNF-3A
Part no. 560 315

Material: Fluoroelastomer
Durometer: 75 ± 5 Shore A
Operating temperature: -40...+204 °C (-40...+400 °F)

Controlling design dimensions are in millimeters and measurements in () are in inches

Manuals, Software & 3D Models available at:
www.mtssensors.com

ORDER CODE

1	2	3	4	5	6	7	8	9	10	11	12	13	14	15	16	17	18
T	H										1			S	N		
a		b	c					d			e	f	g	h	i		

a	Sensor model
T H	Rod

b	Design
Enclosure Type 3: TH rod sensor with housing material stainless steel 1.4305 (AISI 303) and rod material stainless steel 1.4306 (AISI 304L)	

M	Threaded flange with flat-face (M18×1.5-6g)
N	Threaded flange with raised-face (M18×1.5-6g)
S	Threaded flange with flat-face (¾"-16 UNF-3A)
T	Threaded flange with raised-face (¾"-16 UNF-3A)

Enclosure Type 3X: TH rod sensor with housing material stainless steel 1.4404 (AISI 316L) and rod material stainless steel 1.4404 (AISI 316L)

F	Threaded flange with flat-face (¾"-16 UNF-3A)
G	Threaded flange with raised-face (¾"-16 UNF-3A)
W	Threaded flange with flat-face (M18×1.5-6g)

c	Stroke length
----------	----------------------

X X X X M	0025...1500 mm
-----------	----------------

Standard stroke length (mm)*	Ordering steps
25 ... 500 mm	5 mm
500 ... 750 mm	10 mm
750...1000 mm	25 mm
1000...1500 mm	50 mm

X X X X U	001.0...060.0 in.
-----------	-------------------

Standard stroke length (in.)*	Ordering steps
1...20 in.	0.2 in.
20...30 in.	0.4 in.
30...40 in.	1.0 in.
40...60 in.	2.0 in.

d	Connection type
----------	------------------------

C 0 1	Side connection with thread ½"-14 NPT (All versions)
-------	--

C 1 0	Top connection with thread ½"-14 NPT (All versions)
-------	---

M 0 1	Side connection with thread M16×1.5-6H (Version E & N)
-------	--

M 1 0	Top connection with thread M16×1.5-6H (Version E & N)
-------	---

d	Connection type (continued)
----------	------------------------------------

N 0 1	Side connection with thread M20×1.5-6H (All versions)
-------	---

N 1 0	Top connection with thread M20×1.5-6H (All versions)
-------	--

e	Operating voltage
----------	--------------------------

1	+24 VDC (-15 / +20 %)
---	-----------------------

f	Version (see "Certifications" on page 4 for further information)
----------	--

D	Ex db and Ex tb (A/F 55)
---	--------------------------

E	Ex db eb and Ex tb (A/F 55) US & CA approval: Ex nA /NI (for Zone 2 and 22)
---	--

G	Ex db and Ex tb (A/F 60) US & CA approval: Explosionproof (XP) (Note: Group A is not available for Canada)
---	--

N	Not approved
---	--------------

g	Functional safety type
----------	-------------------------------

S	SIL 2 (with certificate and safety manual)
---	--

h	Additional option type
----------	-------------------------------

N	None
---	------

i	Output
----------	---------------

1 output with 1 position magnet Output 1 (position magnet 1)	
---	--

A 0 1	4...20 mA
-------	-----------

A 1 1	20...4 mA
-------	-----------

DELIVERY



Sensor

Accessories have to be ordered separately

Manuals, Software & 3D Models available at:
www.mtssensors.com

* / Non Standard stroke lengths are available; must be encoded in 5 mm / 0.1 in. increments

UNITED STATES 3001 Sheldon Drive
 MTS Systems Corporation Cary, N.C. 27513
 Sensors Division Phone: +1 919 677-0100
 E-mail: info.us@mtssensors.com

GERMANY Auf dem Schüffel 9
 MTS Sensor Technologie 58513 Lüdenscheid
 GmbH & Co. KG Phone: +49 2351 9587-0
 E-mail: info.de@mtssensors.com

ITALY Phone: +39 030 988 3819
 Branch Office E-mail: info.it@mtssensors.com

FRANCE Phone: +33 1 58 4390-28
 Branch Office E-mail: info.fr@mtssensors.com

GREAT BRITAIN Phone: +44 79 44 15 03 00
 Branch Office E-mail: info.uk@mtssensors.com

CHINA Phone: +86 21 6485 5800
 Branch Office E-mail: info.cn@mtssensors.com

JAPAN Phone: +81 3 6416 1063
 Branch Office E-mail: info.jp@mtssensors.com

Document Part Number:
 551603 Revision G (EN) 01/2019



www.mtssensors.com