

Tempsonics®

Magnetostrictive Linear Position Sensors

R-Series V RP5 SSI Data Sheet

- Position measurement with a resolution up to 0.1 μm
- Update rate up to 10 kHz
- Field adjustments and diagnostics using the new TempoLink smart assistant



V
THE NEW GENERATION

MEASURING TECHNOLOGY

The absolute, linear position sensors provided by MTS Sensors rely on the company's proprietary Temposonics® magnetostrictive technology, which can determine position with a high level of precision and robustness. Each Temposonics® position sensor consists of a ferromagnetic waveguide, a position magnet, a strain pulse converter and supporting electronics. The magnet, connected to the object in motion in the application, generates a magnetic field at its location on the waveguide. A short current pulse is applied to the waveguide. This creates a momentary radial magnetic field and torsional strain on the waveguide. The momentary interaction of the magnetic fields releases a torsional strain pulse that propagates the length of the waveguide. When the ultrasonic wave reaches the end of the waveguide it is converted into an electrical signal. Since the speed of the ultrasonic wave in the waveguide is precisely known, the time required to receive the return signal can be converted into a linear position measurement with both high accuracy and repeatability.

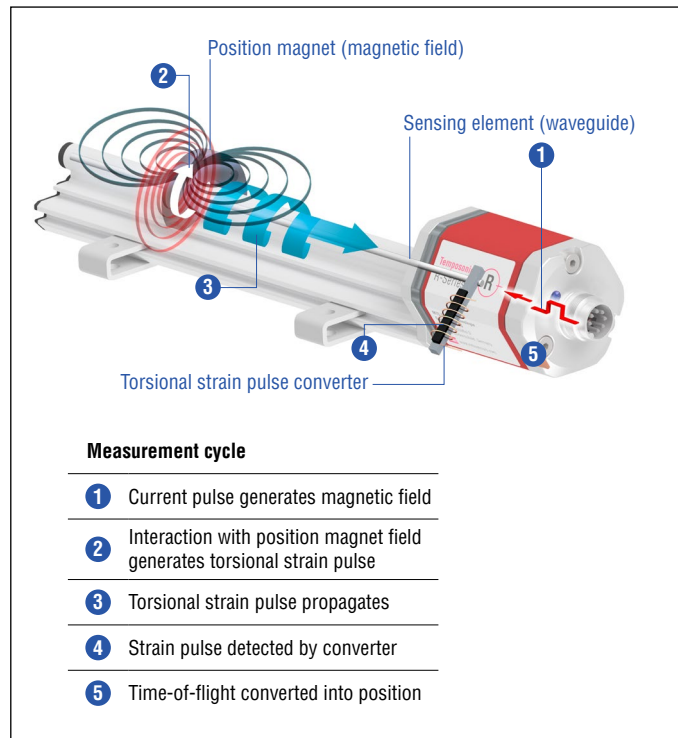

Fig. 1: Time-of-flight based magnetostrictive position sensing principle

R-SERIES V SSI

Temposonics® R-Series V brings very powerful sensor performance to meet the many demands of your application. The R-Series V is the long term solution for harsh environments that have high levels of shock and vibration. The sensor with SSI output (Synchronous Serial Interface) is characterized by a very stable position signal with a minimum resolution of 0.1 μm . The sensor offers one asynchronous mode as well as three different synchronous modes for measurement. The synchronous modes also support linear extrapolation. This allows a cycle time of 100 μs or the readout of the data with up to 10 kHz for any stroke length of the sensor. Temposonics® R-Series V sensors are available with internal linearization which offers improved linearity for overall higher accuracy of the position measurement value.

With many outstanding features, the R-Series V model sensors are ideal for a very broad range of applications.

TempoLink YOUR SMART ASSISTANT

The TempoLink smart assistant is an accessory for the R-Series V family of sensors that supports setup and diagnostics. Depending on the sensor protocol it enables the adjustment of parameters like measurement direction, resolution and filter settings. For diagnostics and analysis of operational data the R-Series V sensors continuously track values such as total distance traveled by the position magnet, internal temperature of the sensor and the quality of the position signal. This additional information can be read out via TempoLink smart assistant even while the sensor remains operational in the application.

TempoLink smart assistant is connected to the sensor via the power connection, which now adds bidirectional communication for setup and diagnostics. The TempoLink smart assistant is operated using a graphical user-interface that will be displayed on your smartphone, tablet, laptop or PC. Just connect your Wi-Fi-enabled device to TempoLink Wi-Fi access point and go to the website URL for the user-interface.



Fig. 2: R-Series V sensor with TempoLink smart assistant

TECHNICAL DATA

Output							
Interface	SSI (Synchronous Serial Interface) – differential signal in SSI standard (RS-485/RS-422)						
Data format	Binary or gray						
Data length	8...32 bit						
Data transmission rate	70 kBaud ¹ ...1 MBaud, depending on cable length:						
	Cable length	< 3 m	< 50 m	< 100 m	< 200 m	< 400 m	
	Baud rate	1 MBd	< 400 kBd	< 300 kBd	< 200 kBd	< 100 kBd	
Measured value	Position						
Measurement parameters							
Resolution: Position	0.1...100 µm (0.0001...0.1 mm)						
Resolution: Velocity	0.001 mm/s (determined over 10 measured values)						
Update rate ²	Stroke length	25 mm	300 mm	750 mm	1000 mm	2000 mm	6350 mm
	Update rate	10 kHz	3.4 kHz	2.7 kHz	2.1 kHz	1.2 kHz	0.4 kHz
Linearity deviation ³	Stroke length	≤ 400 mm	> 400 mm				
	Linearity deviation	≤ ±40 µm	< ±0.01 % F.S.				
	Optional internal linearization: Linearity tolerance (applies for the first magnet for differential measurement)						
	Stroke length	25...300 mm	300...600 mm	600...1200 mm	1200...3000 mm	3000...5000 mm	5000...6350 mm
	typical	± 15 µm	± 20 µm	± 25 µm	± 45 µm	± 85 µm	± 95 µm
	maximum	± 25 µm	± 30 µm	± 50 µm	± 90 µm	± 150 µm	± 190 µm
Repeatability	< ±0.001 % F.S. (minimum ±2.5 µm) typical						
Hysteresis	< 4 µm typical						
Temperature coefficient	< 15 ppm/K typical						
Operating conditions							
Operating temperature	–40...+85 °C (–40...+185 °F)						
Humidity	90 % relative humidity, no condensation						
Ingress protection	IP67 (connectors correctly fitted)/IP68 for cable output						
Shock test	150 g/11 ms, IEC standard 60068-2-27						
Vibration test	30 g/10...2000 Hz, IEC standard 60068-2-6 (excluding resonant frequencies)						
EMC test	Electromagnetic emission according to EN 61000-6-3						
	Electromagnetic immunity according to EN 61000-6-2						
	The sensor meets the requirements of the EC directives and is marked with CE						
Magnet movement velocity	Magnet slider: Max. 10 m/s; U-magnet: Any; block magnet: Any						
Design/Material							
Sensor electronics housing	Aluminum (painted), zinc die cast						
Sensor profile	Aluminum						
Stroke length	25...6350 mm (1...250 in.)						
Mechanical mounting							
Mounting position	Any						
Mounting instruction	Please consult the technical drawings on page 4 and the operation manual (document number: 552011)						
Electrical connection							
Connection type	1 × M16 male connector (7 pin) or cable output						
Operating voltage	+12...30 VDC ±20 % (9.6...36 VDC)						
Power consumption	1.2 W typical						
Dielectric strength	500 VDC (DC ground to machine ground)						
Polarity protection	Up to –36 VDC						
Overvoltage protection	Up to 36 VDC						

1/ With standard one shot of 16 µs

2/ Sensor with standard settings. Further information can be found in the operation manual R-Series V SSI (document number: [552011](#))

3/ With position magnet # 252 182

TECHNICAL DRAWING

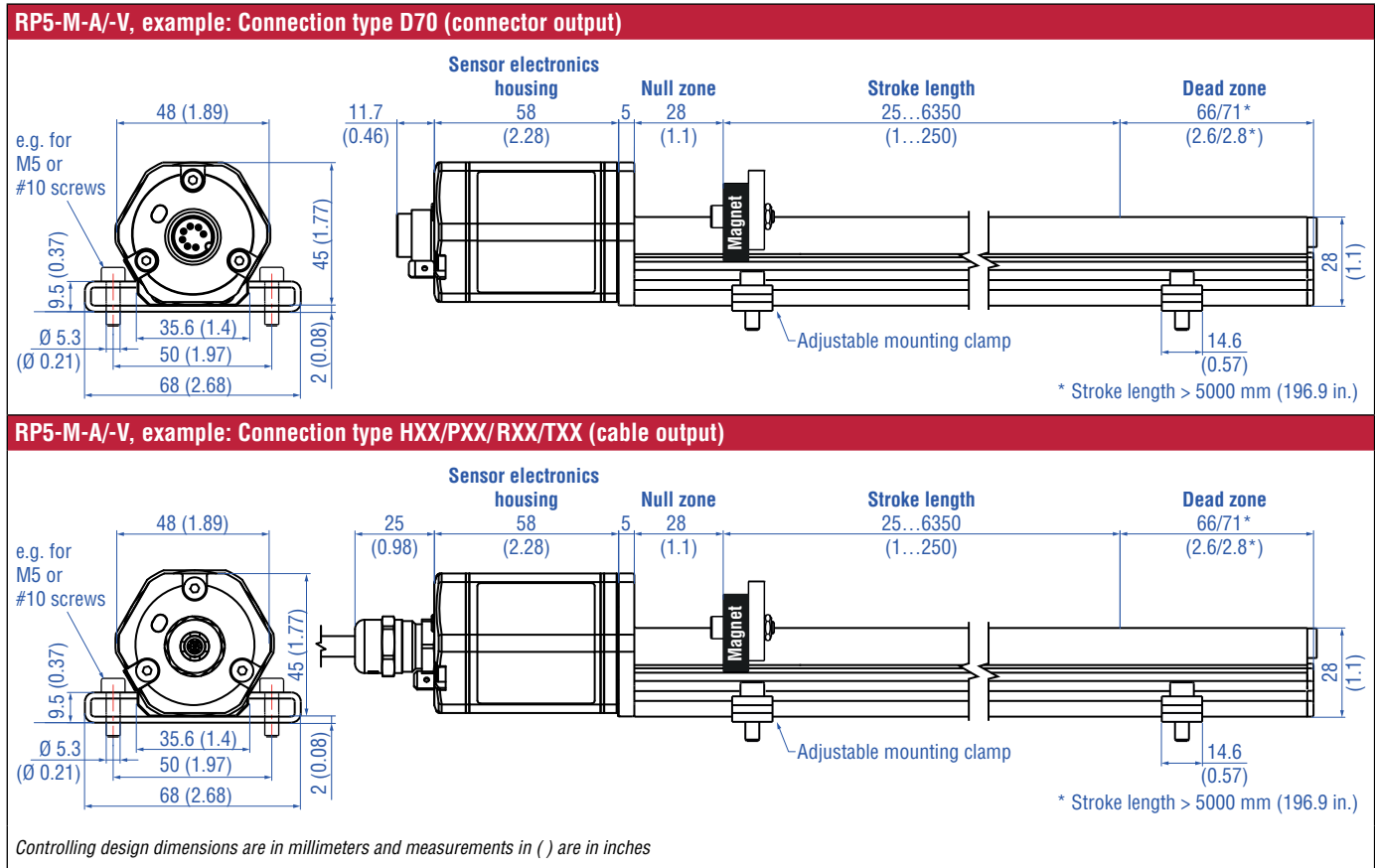

Fig. 3: Temposonics® RP5 with U-magnet

CONNECTOR WIRING

D70		
Signal + power supply		
M16 male connector	Pin	Function
<p>View on sensor</p>	1	Data (-)
	2	Data (+)
	3	Clock (+)
	4	Clock (-)
	5	+12...30 VDC ($\pm 20\%$)
	6	DC Ground (0 V)
	7	Not connected

Fig. 4: Connector wiring D70

HXX / PXX / RXX / TXX		
Signal + power supply		
Cable	Color	Function
	GY	Data (-)
	PK	Data (+)
	YE	Clock (+)
	GN	Clock (-)
	BN	+12...30 VDC ($\pm 20\%$)
	WH	DC Ground (0 V)

For cable type TXX, the extra red & blue wires are not used.

Fig. 5: Connector wiring cable output



FREQUENTLY ORDERED ACCESSORIES – Additional options available in our [Accessories Guide](#) 551444

Position magnets			
<p>Magnet slider S, joint at top Part no. 252 182</p>	<p>Magnet slider V, joint at front Part no. 252 184</p>	<p>Magnet slider N longer ball-joint arm Part no. 252 183</p>	<p>Magnet slider G, backlash free Part no. 253 421</p>
<p>Material: GRP, magnet hard ferrite Weight: Approx. 35 g Operating temperature: -40...+85 °C (-40...+185 °F)</p>	<p>Material: GRP, magnet hard ferrite Weight: Approx. 35 g Operating temperature: -40...+85 °C (-40...+185 °F)</p>	<p>Material: GRP, magnet hard ferrite Weight: Approx. 35 g Operating temperature: -40...+85 °C (-40...+185 °F)</p>	<p>Material: GRP, magnet hard ferrite Weight: Approx. 25 g Operating temperature: -40...+85 °C (-40...+185 °F)</p>

Position magnets		Mounting accessories	
<p>U-magnet OD33 Part no. 251 416-2</p>	<p>Block magnet L Part no. 403 448</p>	<p>Mounting clamp Part no. 400 802</p>	<p>T-nut Part no. 401 602</p>
<p>Material: PA ferrite GF20 Weight: Approx. 11 g Surface pressure: Max. 40 N/mm² Fastening torque for M4 screws: 1 Nm Operating temperature: -40...+105 °C (-40...+221 °F)</p>	<p>Material: Plastic carrier with hard ferrite magnet Weight: Approx. 20 g Fastening torque for M4 screws: 1 Nm Operating temperature: -40...+75 °C (-40...+167 °F)</p> <p>This magnet may influence the sensor performance specifications for some applications.</p>	<p>Material: Stainless steel (AISI 304)</p>	<p>Fastening torque for M5 screw: 4.5 Nm</p>

Controlling design dimensions are in millimeters and measurements in () are in inches

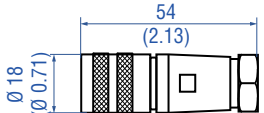
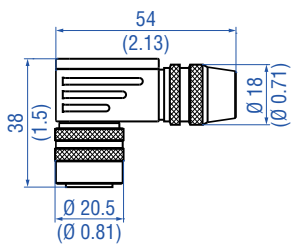
Cable connectors* **Programming tool**

		
<p>M16 female connector (7 pin), straight Part no. 370 624</p> <p>Material: Zinc nickel plated Termination: Solder Contact insert: Silver plated Cable clamp: PG9 Cable Ø: 6...8 mm (0.24...0.31 in.) Operating temperature: -40...+100 °C (-40...+212 °F) Ingress protection: IP65/IP67 (correctly fitted) Fastening torque: 0.7 Nm</p>	<p>M16 female connector (7 pin), angled Part no. 560 779</p> <p>Material: Zinc nickel plated Termination: Solder Contact insert: Silver plated Cable clamp: PG9 Cable Ø: 6...8 mm (0.24...0.31 in.) Operating temperature: -40...+100 °C (-40...+212 °F) Ingress protection: IP65/IP67 (correctly fitted) Fastening torque: 0.7 Nm</p>	<p>TempoLink kit for Temposonics® R-Series V Part no. TL-1-0-SD70 (for D70) Part no. TL-1-0-AS00 (for cable output)</p> <ul style="list-style-type: none"> • Connect wirelessly via Wi-Fi enabled device or via USB with the diagnostic tool • Simple connectivity to the sensor via 24 VDC power line (permissible cable length: 30 m) • User friendly interface for mobile devices and desktop computers • See data sheet "TempoLink smart assistant" (document part no.: 552070) for further information

Cables

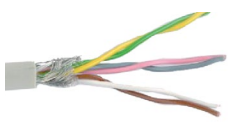
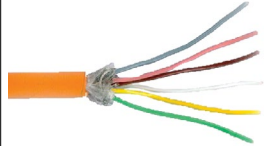
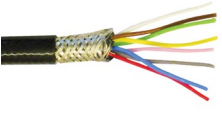
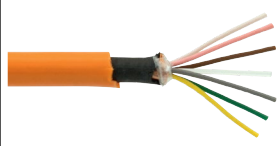
			
<p>PVC cable Part no. 530 032</p> <p>Material: PVC jacket; gray Features: Twisted pair, shielded, flexible Cable Ø: 6 mm (0.23 in.) Cross section: 3 × 2 × 0.14 mm² Bending radius: 10 × D (fixed installation) Operating temperature: -40...+105 °C (-40...+221 °F)</p>	<p>PUR cable Part no. 530 052</p> <p>Material: PUR jacket; orange Features: Twisted pair, shielded, highly flexible, halogen free, energy chain capable, mostly oil & flame resistant Cable Ø: 6.4 mm (0.25 in.) Cross section: 3 × 2 × 0.25 mm² Bending radius: 5 × D (fixed installation) Operating temperature: -30...+80 °C (-22...+176 °F)</p>	<p>Teflon® cable Part no. 530 112</p> <p>Material: Teflon® jacket; black Features: Twisted pair, shielded, flexible, high thermal resistance, mostly oil & acid resistant Cable Ø: 7.6 mm (0.3 in.) Cross section: 4 × 2 × 0.25 mm² Bending radius: 8 – 10 × D (fixed installation) Operating temperature: -100...+180 °C (-148...+356 °F)</p>	<p>PUR cable Part no. 530 175</p> <p>Material: PUR jacket; orange Features: Flexible, additional EMC protection Cable Ø: 6.5 mm (0.26 in.) Cross section: 6 × 0.14 mm² Bending radius: 10 × D (fixed installation) Operating temperature: -30...+90 °C (-22...+194 °F)</p>

*/ Follow the manufacturer's mounting instructions

Controlling design dimensions are in millimeters and measurements in () are in inches

ORDER CODE

1	2	3	4	5	6	7	8	9	10	11	12	13	14	15	16	17	18	19	20	21	22	23	24	25	26	27							
R	P	5													1	S																	
a			b		c		d				e		f			g	h		i		j		k		l		m		n		o		

optional

a	Sensor model		
R	P	5	Profile

b	Design	
G	Magnet slider backlash free (part no. 253 421), suitable for internal linearization	
L	Block magnet L (part no. 403 448)	
M	U-magnet OD33 (part no. 251 416-2), suitable for internal linearization	
N	Magnet slider longer ball-jointed arm (part no. 252 183), suitable for internal linearization	
O	No position magnet	
S	Magnet slider joint at top (part no. 252 182), suitable for internal linearization	
V	Magnet slider joint at front (part no. 252 184), suitable for internal linearization	

c	Mechanical options	
A	Standard	
V	Fluorelastomer seals for the sensor electronics housing	

d	Stroke length				
X	X	X	X	M	0025...6350 mm
Standard stroke length (mm)		Ordering steps			
25... 500 mm		25 mm			
500...2500 mm		50 mm			
2500...5000 mm		100 mm			
5000...6350 mm		250 mm			
X	X	X	X	U	001.0...250.0 in.
Standard stroke length (in.)		Ordering steps			
1... 20 in.		1.0 in.			
20...100 in.		2.0 in.			
100...200 in.		4.0 in.			
200...250 in.		10.0 in.			
Non-standard stroke lengths are available; must be encoded in 5 mm/0.1 in. increments.					

e	Number of magnets	
X	X	01...02 position(s) (1...2 magnet(s))

f	Connection type		
D	7	0	M16 male connector (7 pin)
H	X	X	XX m PUR cable (part no. 530 052) H01...H30 (1...30 m/3...99 ft.) See "Frequently ordered accessories" for cable specifications
P	X	X	XX m PUR cable (part no. 530 175) P01...P30 (1...30 m/3...99 ft.) See "Frequently ordered accessories" for cable specifications
R	X	X	XX m PVC cable (part no. 530 032) R01...R30 (1...30 m/3...99 ft.) See "Frequently ordered accessories" for cable specifications
T	X	X	XX m Teflon® cable (part no. 530 112) T01...T30 (1...30 m/3...99 ft.) See "Frequently ordered accessories" for cable specifications
Encode in meters if using metric stroke length. Encode in feet if using US customary stroke length.			

g	System	
1	Standard	

h	Output	
S	SSI	

i	Function	
1	Position	
2	Differential measurement (2 magnets and 1 output)	
3	Velocity	
4	Position and temperature in the sensor electronics housing; NOTICE In this case, only option 2 "24 bit" can be selected under 1 "Data length".	

j	Options	
0	Standard	
1	Internal linearization	

Temposonics® R-Series V RP5 SSI

Data Sheet

k	Mode
1	Measuring direction forward, asynchronous mode
2	Measuring direction forward, synchronous mode 1
3	Measuring direction forward, synchronous mode 2
4	Measuring direction forward, synchronous mode 3
5	Measuring direction reverse, asynchronous mode
6	Measuring direction reverse, synchronous mode 1
7	Measuring direction reverse, synchronous mode 2
8	Measuring direction reverse, synchronous mode 3

l	Data length
1	25 bit
2	24 bit
3	26 bit
A	24 bit + alarm bit + parity bit

m	Format
B	Binary
G	Gray

n	Resolution
1	5 µm
2	10 µm
3	50 µm
4	100 µm
5	20 µm
6	2 µm
7	0.1 µm
8	1 µm
9	0.5 µm

o	Additional options (optional)
S 0 0 2	FIR filter (2 measurements)
S 0 0 4	FIR filter (4 measurements)
S 0 0 8	FIR filter (8 measurements)
S 0 0 A	No filter, error counter (4 cycles)
S 0 0 C	No filter, error counter (8 cycles)
S 0 0 D	No filter, error counter (10 cycles)
S 0 0 G	FIR filter (8 measurements), error counter (10 cycles)
S 0 0 J	IIR filter (filter grade 4)
S 0 0 K	IIR filter (filter grade 8)
S 0 0 N	IIR filter (filter grade 4), error counter (10 cycles)

NOTICE

- For the RP5, the magnet selected in **b** "Design" is included in the scope of delivery. Specify the number of magnets for your application. For differential measurements order the second magnet separately.
- The number of magnets is limited by the stroke length. The minimum allowed distance between magnets (i.e. front face of one to the front face of the next one) is 75 mm (3 in.).
- Use magnets of the same type for differential measurement, e.g. 2 × U-magnet (part no. 251 416-2).
- If the option for internal linearization in **j** "Options" is chosen, select a suitable magnet.

DELIVERY



- Sensor
 - Position magnet (not valid for RP5 with design »Q«)
 - 2 mounting clamps up to 1250 mm (50 in.) stroke length
+ 1 mounting clamp for each 500 mm (20 in.) additional stroke length
- Accessories have to be ordered separately.

Manuals, Software & 3D Models available at:
www.mtssensors.com

GLOSSARY

A
<p>Alarm The alarm bit is set by the sensor if the sensor detects more magnets (extra magnet) or less magnets (magnet status error) than configured.</p> <p>Asynchronous mode In asynchronous mode the position data is continuously updated inside the sensor as quickly as the sensor's measurement cycle will allow, independent of the controller. The controller's loop time will determine when the sensor's most recent data is clocked out over the SSI interface. (→ Synchronous mode)</p>
D
<p>Differential measurement For differential measurement, the distance between the two position magnets is output as a value.</p>
E
<p>Extrapolation The native measurement cycle time of a sensor increases with the stroke length. With extrapolation, the sensor is able to report data faster than the native cycle time, independent of the stroke length of the sensor. Without extrapolation, if data is requested faster than the native cycle time, the last measured value is repeated.</p>
F
<p>FIR Filter The FIR filter (Finite Impulse Response) is used to smooth the measured position value before output. To determine the output value, only input values corresponding to the window (filter window size) are used for filter calculation. The output value is calculated from these input values in the form of a moving average value. (→ IIR Filter)</p>
I
<p>IIR Filter The IIR filter (Infinite Impulse Response) is used to smooth the measured position value before output. To determine the output value, the input values corresponding to the filter grade (filter window size) are used for the filter calculation. The previous values are also taken into account when calculating the output value. (→ FIR Filter)</p> <p>Internal Linearization The internal linearization offers an improved linearity for an overall higher accuracy of the position measurement. The internal linearization is set for the sensor during production.</p>
M
<p>Measuring direction When moving the position magnet, the position and velocity values increase in the measuring direction.</p> <ul style="list-style-type: none"> • Forward: Values increasing from sensor electronics housing to rod end/profile end • Reverse: Values decreasing from sensor electronics housing to rod end/profile end

P
<p>Parity The parity bit is a check bit that is added to a bit string to detect transmission errors. There are even parity and odd parity. With even parity, the parity bit is set so that the total number of 1-bits in the bit string including the parity bit is even. In case of odd parity, the total number of 1-bits in the bit sequence including the parity bit is odd. Even parity is implemented in the R-Series V SSI.</p>
S
<p>Synchronous Serial Interface SSI (Synchronous Serial Interface) is a digital interface where the data is transferred serially. The interface of R-Series V SSI corresponds to SSI industry standard for absolute encoders. Its displacement value is encoded in a 24/25/26 bit binary or gray format and transmitted as a differential signal in SSI standard (RS-485/RS-422).</p> <p>Synchronous mode In synchronous mode the measurement and output of the sensor is matched to the data request cycle of the controller. The synchronous mode minimizes the time delay between measurement and output. The synchronous mode is required for sophisticated motion control applications. (→ Asynchronous mode)</p> <ul style="list-style-type: none"> • Synchronous mode 1 Using synchronous mode 1, the sensor determines the controller's loop timing and when data is being requested. The sensor then determines when to start the next measurement cycle so that it will complete just in time to deliver the freshest data possible. • Synchronous mode 2 If new position data is required faster than the sensor's measurement cycle time, synchronous mode 2 provides extrapolated data values, calculated on the fly. A measurement value will be calculated and output to the controller whenever the sensor has not yet completed the next measurement cycle. • Synchronous mode 3 Synchronous mode 3 provides an additional enhancement to the high speed update feature of synchronous mode 2. For this mode all measurements values which are output are calculated to fully compensate for the inherent lag time due to the sensor's measurement cycle.
T
<p>Temperature in the sensor electronics housing The temperature in the sensor electronics housing is measured in °C. With this option, the transmitted data word has a length of 32 bits, with the highest 8 bits representing the temperature value, followed by 24 bits for the position value.</p>

USA 3001 Sheldon Drive
MTS Systems Corporation Cary, N.C. 27513
Sensors Division Telefon: +1 919 677-0100
Amerika & APAC Region E-Mail: info.us@mtssensors.com

DEUTSCHLAND Auf dem Schüffel 9
MTS Sensor Technologie 58513 Lüdenscheid
GmbH & Co. KG Telefon: +49 2351 9587-0
EMEA Region & Indien E-Mail: info.de@mtssensors.com

ITALIEN Telefon: +39 030 988 3819
Zweigstelle E-Mail: info.it@mtssensors.com

FRANKREICH Telefon: +33 1 58 4390-28
Zweigstelle E-Mail: info.fr@mtssensors.com

UK Telefon: +44 79 44 15 03 00
Zweigstelle E-Mail: info.uk@mtssensors.com

SKANDINAVIEN Telefon: +46 70 29 91 281
Zweigstelle E-Mail: info.sca@mtssensors.com

CHINA Telefon: +86 21 2415 1000 / 2415 1001
Zweigstelle E-Mail: info.cn@mtssensors.com

JAPAN Telefon: +81 3 6416 1063
Zweigstelle E-Mail: info.jp@mtssensors.com

Document Part Number:
552000 Revision C (EN) 12/2020



www.mtssensors.com