

Temposonics®

Magnetostrictive Linear Position Sensors

Temposonics® R-Series V SSI Operation Manual



V
THE NEW GENERATION

Table of contents

1. Introduction	3
1.1 Purpose and use of this manual	3
1.2 Used symbols and warnings	3
2. Safety instructions	3
2.1 Intended use	3
2.2 Foreseeable misuse	3
2.3 Installation, commissioning and operation	4
2.4 Safety instructions for use in explosion-hazardous areas	4
2.5 Warranty	4
2.6 Return	4
3. Identification	5
3.1 Order code Temposonics® RP5	5
3.2 Order code Temposonics® RH5	7
3.3 Nameplate	9
3.4 Approvals	9
3.5 Scope of delivery	9
4. Product description	10
4.1 Functionality and system design	10
4.2 Installation Temposonics® RP5	11
4.3 Installation Temposonics® RH5	12
4.4 Magnet installation	15
4.5 Alignment of the magnet with the option “Internal linearization”	17
4.6 Replacement of base unit	18
4.7 Electrical connection	19
4.8 Frequently ordered accessories for sensor model RP5	20
4.9 Frequently ordered accessories for sensor model RH5	21
4.10 Frequently ordered accessories for SSI output	22
5. Commissioning	23
5.1 Introduction	23
5.2 LED status	24
5.3 Programming and configuration	25
5.3.1 Connection of TempoLink smart assistant to R-Series V sensor	25
5.3.2 Connection of TempoLink smart assistant to power supply	26
5.3.3 Connection of TempoLink smart assistant to smartphone, tablet or computer	27
5.3.4 Establishing a connection via browser	27
5.3.5 Graphical user interface	28
6. Maintenance and troubleshooting	30
6.1 Error conditions, troubleshooting	30
6.2 Maintenance	30
6.3 Repair	30
6.4 List of spare parts	30
6.5 Transport and storage	30
7. Removal from service/dismantling	30
8. Technical data	31
8.1 Technical data Temposonics® RP5	31
8.2 Technical data Temposonics® RH5	33
9. Appendix I	35
10. Appendix II	36
11. Glossary	37

1. Introduction

1.1 Purpose and use of this manual

Before starting the operation of Temposonics® position sensors, read this documentation thoroughly and follow the safety information. Keep this manual for future reference!

The content of this technical documentation and of its appendices is intended to provide information on mounting, installation and commissioning by qualified automation personnel ¹ or instructed service technicians who are familiar with the project planning and dealing with Temposonics® sensors.

1.2 Used symbols and warnings

Warnings are intended for your personal safety and for avoidance of damage to the described product or connected devices. In this documentation, safety information and warnings to avoid danger that might affect the life and health of operating or service personnel or cause material damage are highlighted by the pictogram defined below.

Symbol	Meaning
NOTICE	This symbol is used to point to situations that may lead to material damage, but not to personal injury.

2. Safety instructions

2.1 Intended use

This product may be used only for the applications defined under item 1 and only in conjunction with the third-party devices and components recommended or approved by MTS Sensors. As a prerequisite of proper and safe operation the product requires correct transport, storage, mounting and commissioning and must be operated with utmost care.

- The sensor systems of all Temposonics® series are intended exclusively for measurement tasks encountered in industrial, commercial and laboratory applications. The sensors are considered as system accessories and must be connected to suitable evaluation electronics, e.g. a PLC, IPC, indicator or other electronic control unit.

^{1/} The term "qualified technical personnel" characterizes persons who:

- are familiar with the safety concepts of automation technology applicable to the particular project
- are competent in the field of electromagnetic compatibility (EMC)

2.2 Foreseeable misuse

Foreseeable misuse	Consequence
Wrong sensor connection	The sensor will not work properly or can be damaged
Operate the sensor out of the operating temperature range	No signal output – the sensor can be damaged
Power supply is out of the defined range	Signal output is wrong/ no signal output/ the sensor will be damaged
Position measurement is influenced by an external magnetic field	Signal output is wrong
Cables are damaged	Short circuit – the sensor can be damaged/sensor does not respond
Spacers are missing/ installed in a wrong order	Error in position measurement
Wrong connection of ground/shield	Signal output is disturbed – the electronics can be damaged
Use of a magnet that is not specified by MTS Sensors	Error in position measurement

Do not alter the sensor afterwards.
→ The sensor might be damaged.

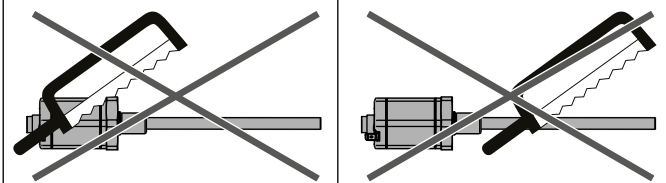

Do not step on the sensor.
→ The sensor might be damaged.

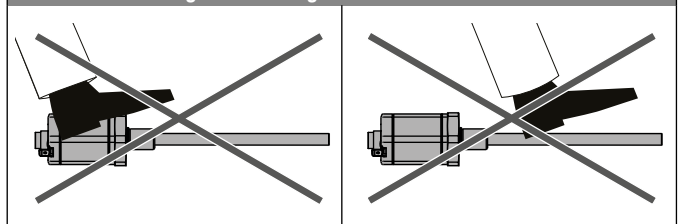

- have received adequate training for commissioning and service operations
- are familiar with the operation of the device and know the information required for correct operation provided in the product documentation

2.3 Installation, commissioning and operation

The position sensors must be used only in technically safe condition. To maintain this condition and to ensure safe operation, installation, connection and service, work may be performed only by qualified technical personnel.

If danger of injury to persons or of damage to operating equipment is caused by sensor failure or malfunction, additional safety measures such as plausibility checks, limit switches, EMERGENCY STOP systems, protective devices etc. are required. In the event of trouble, shut down the sensor and protect it against accidental operation.

Safety instructions for commissioning

To maintain the sensor's operability, it is mandatory to follow the instructions given below.

1. Protect the sensors against mechanical damage during installation and operation.
2. Do not open or dismantle the sensors.
3. Connect the sensors very carefully and pay attention to the polarity of connections and power supply.
4. Use only approved power supplies.
5. Ensure the sensor is operating within the defined limits for supply voltage, environmental conditions, etc..
6. Check the function of the sensors regularly and provide documentation of the checks.
7. Before applying power, ensure that nobody's safety is jeopardized by starting machines.

2.4 Safety instructions for use in explosion-hazardous areas

The sensors are not suitable for operation in explosion-hazardous areas.

2.5 Warranty

MTS Sensors grants a warranty period² for the Temposonics® position sensors and supplied accessories relating to material defects and faults that occur despite correct use in accordance with the intended application. The MTS Sensors obligation is limited to repair or replacement of any defective part of the unit. No warranty can be provided for defects that are due to improper use or above average stress of the product, as well as for wear parts. Under no circumstances will MTS Sensors accept liability in the event of offense against the warranty rules, no matter if these have been assured or expected, even in case of fault or negligence of the company.

MTS Sensors explicitly excludes any further warranties. Neither the company's representatives, agents, dealers nor employees are authorized to increase or change the scope of warranty.

2.6 Return

For diagnostic purposes, the sensor can be returned to MTS Sensors or a repair facility explicitly authorized by MTS Sensors. Any shipment cost is the responsibility of the sender². For a corresponding form, see chapter "9. Appendix I" on page 35.

NOTICE

When returning sensors, place protective caps on male and female connectors of the sensor. For pigtail cables, place the cable ends in a static shielding bag for electrostatic discharge (ESD) protection. Fill the outer packaging around the sensor completely to prevent damage during transport.

^{2/} See also applicable MTS Sensors terms of sales and delivery on:
www.mtssensors.com

3. Identification

3.1 Order code Temposonics® RP5

1	2	3	4	5	6	7	8	9	10	11	12	13	14	15	16	17	18	19	20	21	22	23	24	25	26	27	
R	P	5													1	S											
a			b		c		d				e		f			g	h	i	j	k	l	m	n	o			

optional

a	Sensor model		
R	P	5	Profile

b	Design
G	Magnet slider backlash free (part no. 253 421), suitable for internal linearization
L	Block magnet L (part no. 403 448)
M	U-magnet OD33 (part no. 251 416-2), suitable for internal linearization
N	Magnet slider longer ball-jointed arm (part no. 252 183), suitable for internal linearization
O	No position magnet
S	Magnet slider joint at top (part no. 252 182), suitable for internal linearization
V	Magnet slider joint at front (part no. 252 184), suitable for internal linearization

c	Mechanical options
A	Standard
V	Fluorelastomer seals for the sensor electronics housing

d	Stroke length				
X	X	X	X	M	0025...6350 mm
Standard stroke length (mm)		Ordering steps			
25... 500 mm		25 mm			
500...2500 mm		50 mm			
2500...5000 mm		100 mm			
5000...6350 mm		250 mm			
X	X	X	X	U	001.0...250.0 in.
Standard stroke length (in.)		Ordering steps			
1... 20 in.		1.0 in.			
20...100 in.		2.0 in.			
100...200 in.		4.0 in.			
200...250 in.		10.0 in.			
Non-standard stroke lengths are available; must be encoded in 5 mm/0.1 in. increments.					

e	Number of magnets	
X	X	01...02 position(s) (1...2 magnet(s))

f	Connection type		
D	7	0	M16 male connector (7 pin)
H	X	X	XX m PUR cable (part no. 530 052) H01...H30 (1...30 m/3...99 ft.) See "Frequently ordered accessories" for cable specifications
P	X	X	XX m PUR cable (part no. 530 175) P01...P30 (1...30 m/3...99 ft.) See "Frequently ordered accessories" for cable specifications
R	X	X	XX m PVC cable (part no. 530 032) R01...R30 (1...30 m/3...99 ft.) See "Frequently ordered accessories" for cable specifications
T	X	X	XX m Teflon® cable (part no. 530 112) T01...T30 (1...30 m/3...99 ft.) See "Frequently ordered accessories" for cable specifications
Encode in meters if using metric stroke length. Encode in feet if using US customary stroke length.			

g	System
1	Standard

h	Output
S	SSI

i	Function
1	Position
2	Differential measurement (2 magnets and 1 output)
3	Velocity
4	Position and temperature in the sensor electronics housing; NOTICE In this case, only option 2 "24 bit" can be selected under 1 "Data length".

j	Options
0	Standard
1	Internal linearization

k	Mode
1	Measuring direction forward, asynchronous mode
2	Measuring direction forward, synchronous mode 1
3	Measuring direction forward, synchronous mode 2
4	Measuring direction forward, synchronous mode 3
5	Measuring direction reverse, asynchronous mode
6	Measuring direction reverse, synchronous mode 1
7	Measuring direction reverse, synchronous mode 2
8	Measuring direction reverse, synchronous mode 3

l	Data length
1	25 bit
2	24 bit
3	26 bit
A	24 bit + alarm bit + parity bit

m	Format
B	Binary
G	Gray

n	Resolution
1	5 µm
2	10 µm
3	50 µm
4	100 µm
5	20 µm
6	2 µm
7	0.1 µm
8	1 µm
9	0.5 µm

o	Additional options (optional)			
S	0	0	2	FIR filter (2 measurements)
S	0	0	4	FIR filter (4 measurements)
S	0	0	8	FIR filter (8 measurements)
S	0	0	A	No filter, error counter (4 cycles)
S	0	0	C	No filter, error counter (8 cycles)
S	0	0	D	No filter, error counter (10 cycles)
S	0	0	G	FIR filter (8 measurements), error counter (10 cycles)
S	0	0	J	IIR filter (filter grade 4)
S	0	0	K	IIR filter (filter grade 8)
S	0	0	N	IIR filter (filter grade 4), error counter (10 cycles)

NOTICE

- For the RP5, the magnet selected in **b** "Design" is included in the scope of delivery. Specify the number of magnets for your application. For differential measurements order the second magnet separately.
- The number of magnets is limited by the stroke length. The minimum allowed distance between magnets (i.e. front face of one to the front face of the next one) is 75 mm (3 in.).
- Use magnets of the same type for differential measurement, e.g. 2 × U-magnet (part no. 251 416-2).
- If the option for internal linearization in **j** "Options" is chosen, select a suitable magnet.

3.2 Order code Temposonics® RH5

1	2	3	4	5	6	7	8	9	10	11	12	13	14	15	16	17	18	19	20	21	22	23	24	25	26	27		
R	H	5													1	S												
a			b		c		d					e		f			g	h	i	j	k	l	m	n	o			

optional

a	Sensor model		
R	H	5	Rod

b	Design
B	Base unit (only for replacement)
J	Threaded flange M22×1.5-6g (rod Ø 12.7 mm), stroke length: 25...5900 mm (1...232 in.)
M	Threaded flange M18×1.5-6g (standard)
S	Threaded flange ¾"-16 UNF-3A (standard)
T	Threaded flange ¾"-16 UNF-3A (with raised-face)

c	Mechanical options
A	Standard
B	Bushing on rod end (only for design »M«, »S« & »T«)
M	Thread M4 at rod end (only for design »M«, »S« & »T«)
V	Fluorelastomer seals for the sensor electronics housing

d	Stroke length				
X	X	X	X	M	0025...7620 mm
Standard stroke length (mm)		Ordering steps			
25... 500 mm		5 mm			
500... 750 mm		10 mm			
750...1000 mm		25 mm			
1000...2500 mm		50 mm			
2500...5000 mm		100 mm			
5000...7620 mm		250 mm			
X	X	X	X	U	001.0...300.0 in.
Standard stroke length (in.)		Ordering steps			
1... 20 in.		0.2 in.			
20... 30 in.		0.4 in.			
30... 40 in.		1.0 in.			
40...100 in.		2.0 in.			
100...200 in.		4.0 in.			
200...300 in.		10.0 in.			
Non-standard stroke lengths are available; must be encoded in 5 mm/0.1 in. increments.					

e	Number of magnets	
X	X	01...02 position(s) (1...2 magnet(s))

f	Connection type		
D	7	0	M16 male connector (7 pin)
H	X	X	XX m PUR cable (part no. 530 052) H01...H30 (1...30 m/3...99 ft.) See "Frequently ordered accessories" for cable specifications
P	X	X	XX m PUR cable (part no. 530 175) P01...P30 (1...30 m/3...99 ft.) See "Frequently ordered accessories" for cable specifications
R	X	X	XX m PVC cable (part no. 530 032) R01...R30 (1...30 m/3...99 ft.) See "Frequently ordered accessories" for cable specifications
T	X	X	XX m Teflon® cable (part no. 530 112) T01...T30 (1...30 m/3...99 ft.) See "Frequently ordered accessories" for cable specifications
Encode in meters if using metric stroke length. Encode in feet if using US customary stroke length.			

g	System
1	Standard

h	Output
S	SSI

i	Function
1	Position
2	Differential measurement (2 magnets and 1 output)
3	Velocity
4	Position and temperature in the sensor electronics housing; NOTICE In this case, only option 2 "24 bit" can be selected under 1 "Data length".

j	Options
0	Standard
1	Internal linearization

k	Mode
1	Measuring direction forward, asynchronous mode
2	Measuring direction forward, synchronous mode 1
3	Measuring direction forward, synchronous mode 2
4	Measuring direction forward, synchronous mode 3
5	Measuring direction reverse, asynchronous mode
6	Measuring direction reverse, synchronous mode 1
7	Measuring direction reverse, synchronous mode 2
8	Measuring direction reverse, synchronous mode 3

l	Data length
1	25 bit
2	24 bit
3	26 bit
A	24 bit + alarm bit + parity bit

m	Format
B	Binary
G	Gray

n	Resolution
1	5 µm
2	10 µm
3	50 µm
4	100 µm
5	20 µm
6	2 µm
7	0.1 µm
8	1 µm
9	0.5 µm

o	Additional options (optional)			
S	0	0	2	FIR filter (2 measurements)
S	0	0	4	FIR filter (4 measurements)
S	0	0	8	FIR filter (8 measurements)
S	0	0	A	No filter, error counter (4 cycles)
S	0	0	C	No filter, error counter (8 cycles)
S	0	0	D	No filter, error counter (10 cycles)
S	0	0	G	FIR filter (8 measurements), error counter (10 cycles)
S	0	0	J	IIR filter (filter grade 4)
S	0	0	K	IIR filter (filter grade 8)
S	0	0	N	IIR filter (filter grade 4), error counter (10 cycles)

NOTICE

- Specify the number of magnets for your application and order the magnets separately.
- The number of magnets is limited by the stroke length. The minimum allowed distance between magnets (i.e. front face of one to the front face of the next one) is 75 mm (3 in.).
- Use magnets of the same type for differential measurement, e.g. 2 × U-magnet (part no. 251 416-2).
- If the option for internal linearization in **j** "Options" is chosen, select a suitable magnet.

3.3 Nameplate

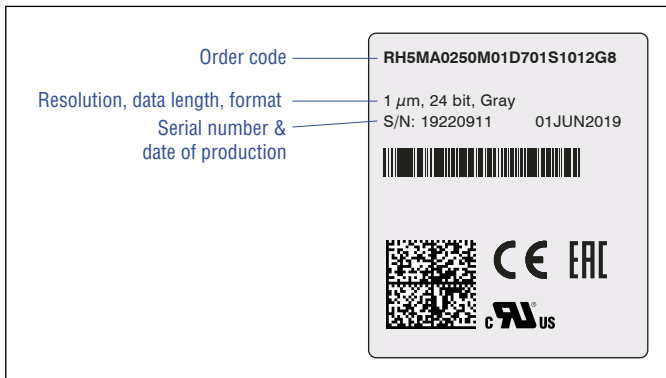

Fig. 1: Example of nameplate of R-Series V RH5 sensor with SSI output

3.4 Approvals

- CE certified
- EAC certified
- UL certified

3.5 Scope of delivery

RP5 (profile sensor):

- Sensor
- Position magnet (not valid for RP5 with design »0«)
- 2 mounting clamps up to 1250 mm (50 in.) stroke length +
1 mounting clamp for each 500 mm (20 in.) additional stroke length

RH5 (rod sensor):

- RH5-B: Base unit (without flange/rod assembly),
3 socket screws M4
- RH5-J/M/S/T: Sensor, O-ring

4. Product description

4.1 Functionality and system design

Product designation

- Position sensor Temposonics® R-Series V

Sensor model

- Temposonics® R-Series V RP5 (profile sensor)
- Temposonics® R-Series V RH5 (rod sensor)

Stroke length

- Temposonics® R-Series V RP5: 25...6350 mm (1...250 in.)
- Temposonics® R-Series V RH5: 25...7620 mm (1...300 in.)

Output signal

- SSI

Application

The Temposonics® position sensors are used for measurement and conversion of the length (position) variable in the fields of automated systems and mechanical engineering.

Principle of operation and system construction

The absolute, linear position sensors provided by MTS Sensors rely on the company's proprietary Temposonics® magnetostrictive technology, which can determine position with a high level of precision and robustness.

Each Temposonics® position sensor consists of a ferromagnetic waveguide, a position magnet, a strain pulse converter and supporting electronics. The magnet, connected to the object in motion in the application, generates a magnetic field at its location on the waveguide. A short current pulse is applied to the waveguide.

This creates a momentary radial magnetic field and torsional strain on the waveguide. The momentary interaction of the magnetic fields releases a torsional strain pulse that propagates the length of the waveguide. When the ultrasonic wave reaches the end of the waveguide it is converted into an electrical signal. Since the speed of the ultrasonic wave in the waveguide is precisely known, the time required to receive the return signal can be converted into a linear position measurement with both high accuracy and repeatability.

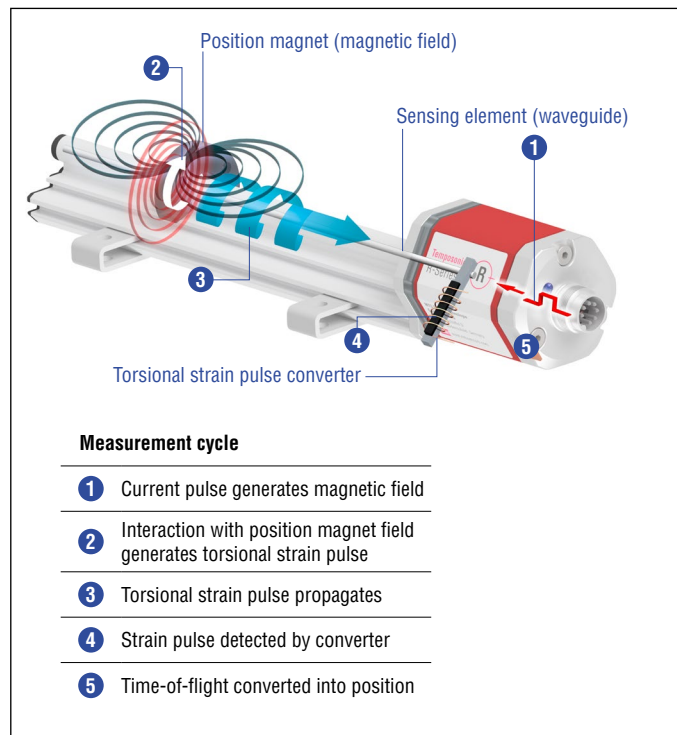

Fig. 2: Time-of-flight based magnetostrictive position sensing principle

Modular mechanical and electronic construction

- The sensor profile or rod protects the inner sensor element.
- The sensor electronics housing, a rugged aluminum construction, contains the complete electronic interface with active signal conditioning.
- The external position magnet is a permanent magnet. Mounted on the mobile machine part, it travels along the sensor profile or rod and triggers the measurement through the sensor profile/rod wall.
- The sensor can be connected directly to a control system. Its electronics generates a strictly position-proportional signal output between start and end position.

4.2 Installation Temposonics® RP5

RP5-M-A/-V, example: Connection type D70 (connector output)

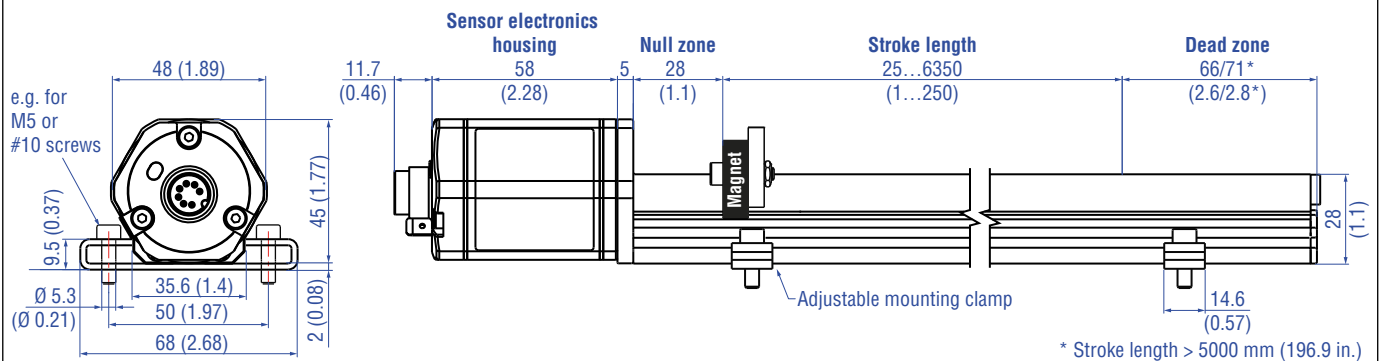

RP5-M-A/-V, example: Connection type HXX/PXX/RXX/TXX (cable output)

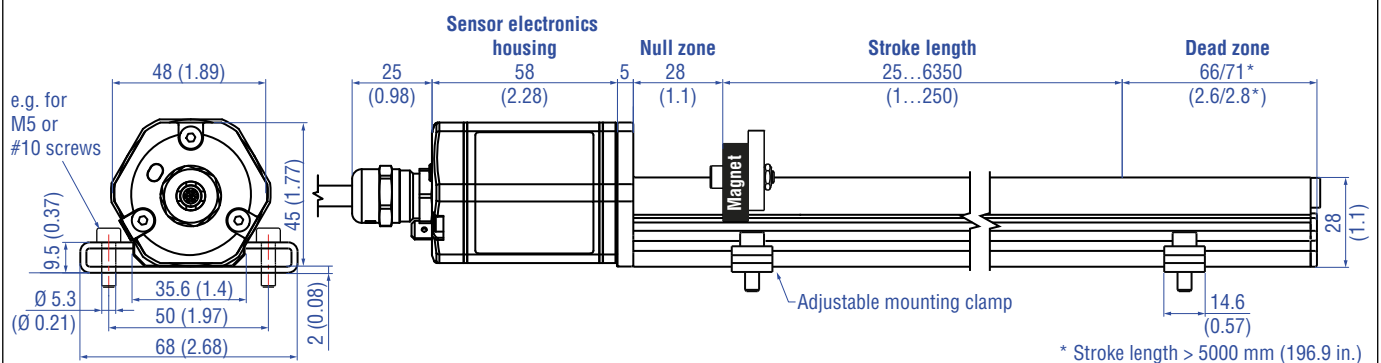

Controlling design dimensions are in millimeters and measurements in () are in inches

Fig. 3: Temposonics® RP5 with U-magnet

Installation of RP5

The position sensor can be installed in any position. Normally, the sensor is firmly installed and the position magnet is fastened to the mobile machine part. Thus it can travel along the sensor profile. The sensor is fitted on a flat machine surface using the mounting clamps (Fig. 4). A length-dependent number of these clamps are delivered with the sensor and must be distributed over the profile at regular distances. For fastening use M5×20 screws to DIN 6912 that should be tightened with a fastening torque of 5 Nm.

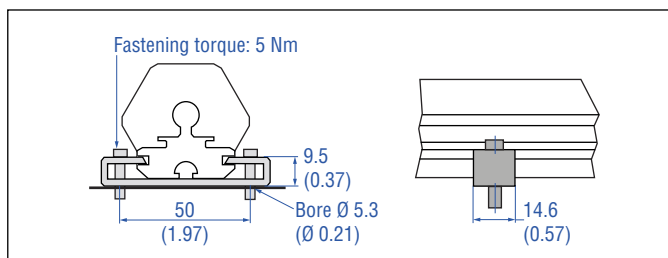

Fig. 4: Mounting clamps (part no. 400 802) with cylinder screw M5×20

Alternative:

If only limited space is available, the profile sensor can be mounted also via the T-rail in the profile bottom using a T-slot nut M5 (part no. 401 602) or a sliding block (Fig. 5).

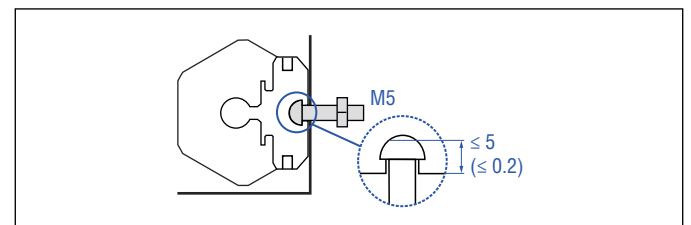

Fig. 5: T-slot nut M5 (part no. 401 602)

NOTICE

Take care to mount the sensor in an axially parallel position to avoid damage to magnet and sensor.

Controlling design dimensions are in millimeters and measurements in () are in inches

4.3 Installation Temposonics® RH5

RH5-M/S-A/-V – RH5 with threaded flange M18×1.5-6g or ¾"-16 UNF-3A, example: Connection type D70 (connector output)

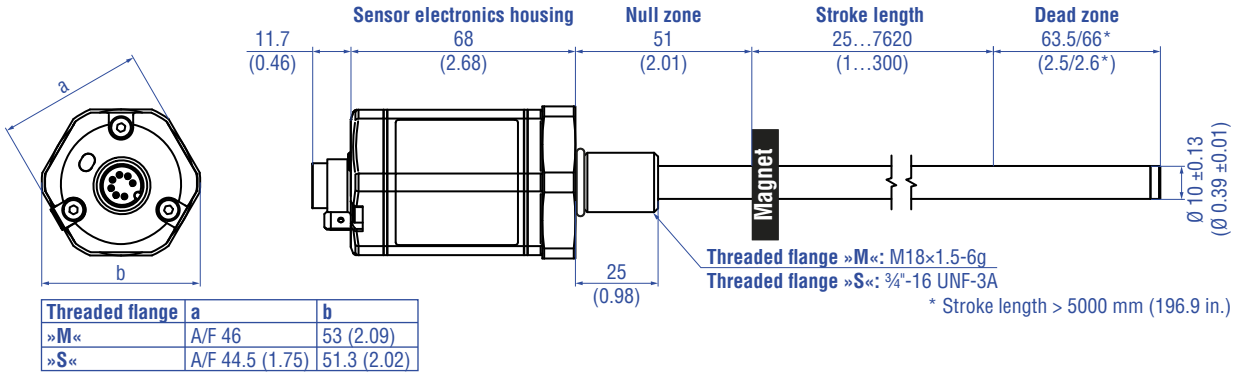

RH5-T-A/-V – RH5 with threaded flange ¾"-16 UNF-3A with raised-face, example: Connection type HXX/PXX/RXX/TXX (cable output)

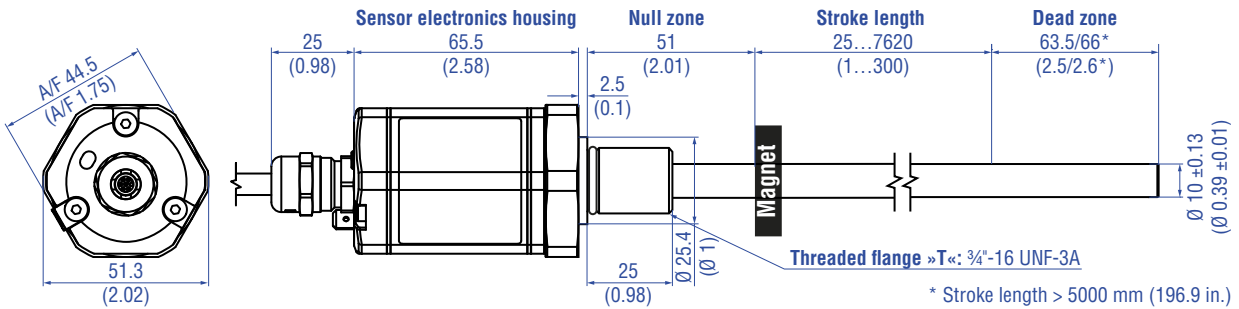

Mechanical option »B«: Bushing on rod end for threaded flange M18×1.5-6g or ¾"-16 UNF-3A

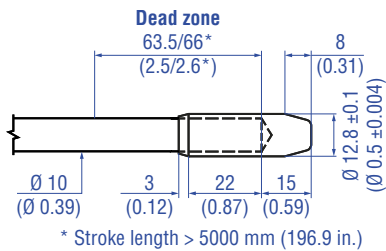

Controlling design dimensions are in millimeters and measurements in () are in inches

Mechanical option »M«: Thread M4 at rod end for threaded flange M18×1.5-6g or ¾"-16 UNF-3A

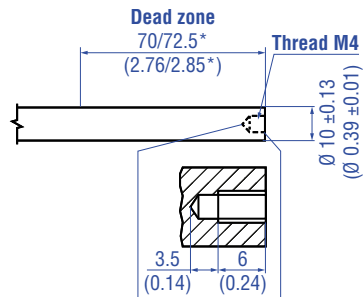
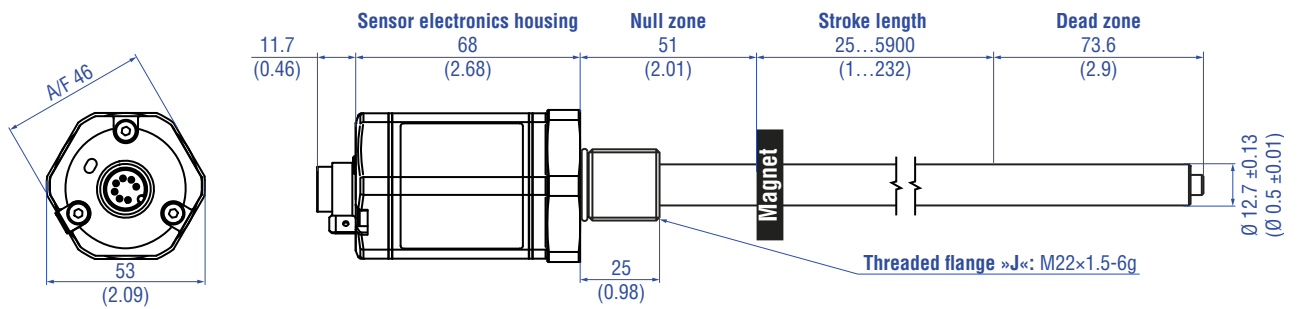
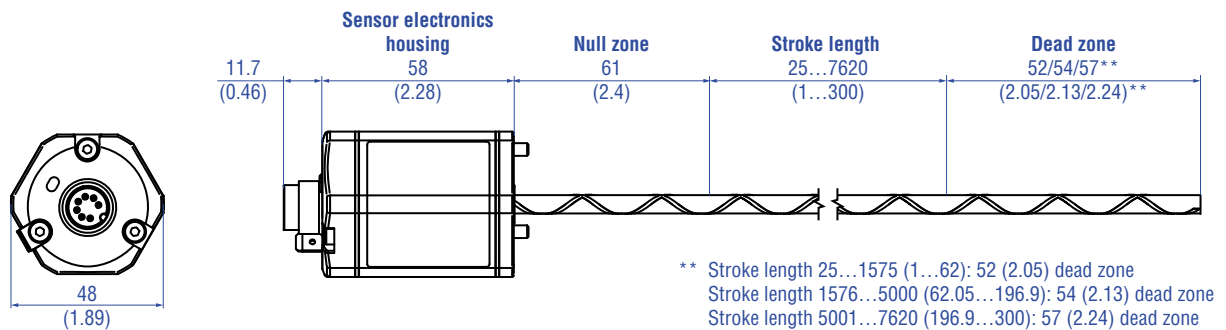

Fig. 6: Temposonics® RH5 with ring magnet, part 1

RH5-J-A/-V – RH5 with threaded flange M22×1.5-6g and Ø 12.7 mm rod, example: Connection type D70 (connector output)



RH5-B-A/-V – RH5 base unit (only for replacement), example: Connection type D70 (connector output)



Controlling design dimensions are in millimeters and measurements in () are in inches

Fig. 7: Temposonics® RH5 with ring magnet, part 2

Installation of RH5 with threaded flange

Fix the sensor rod via threaded flange M18×1.5-6g, M22×1.5-6g or 3/4"-16 UNF-3A.

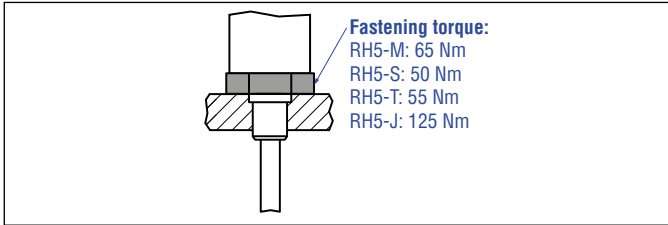

Fig. 8: Mounting example of threaded flange

Installation of a rod-style sensor in a fluid cylinder

The rod-style version has been developed for direct stroke measurement in a fluid cylinder. Mount the sensor via threaded flange or a hex nut.

- Mounted on the face of the piston, the position magnet travels over the rod without touching it and indicates the exact position through the rod wall – independent of the hydraulic fluid.
- The pressure resistant sensor rod is installed into a bore in the piston rod.
- The base unit is mounted by means of three screws. It is the only part that needs to be replaced if servicing is required, i.e. the hydraulic circuit remains closed. For more information see chapter “4.6 Replacement of base unit” on page 18.

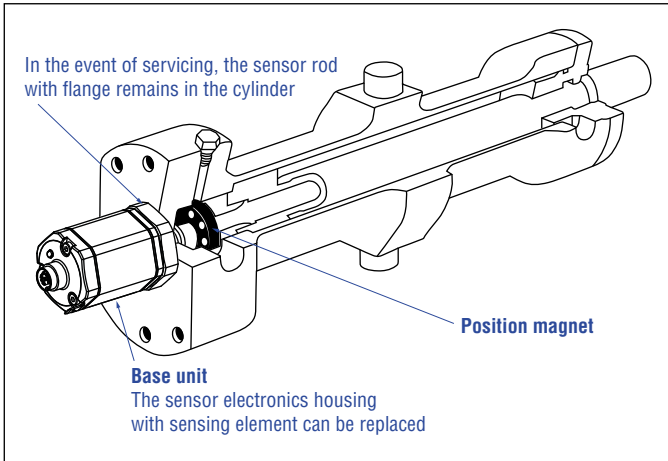

Fig. 9: Sensor in cylinder

Hydraulics sealing

There are two ways to seal the flange contact surface (Fig. 10):

1. A sealing by using an O-ring (e.g. 22.4 × 2.65 mm (0.88 × 0.1 in.), 25.07 × 2.62 mm (0.99 × 0.1 in.)) in a cylinder end cap groove.
2. A sealing by using an O-ring in the undercut.

For threaded flange (3/4"-16 UNF-3A):

O-ring 16.4 × 2.2 mm (0.65 × 0.09 in.) (part no. 560 315)

For threaded flange (M18×1.5-6g):

O-ring 15.3 × 2.2 mm (0.60 × 0.09 in.) (part no. 401 133)

For threaded flange (M22×1.5-6g):

O-ring 19.3 × 2.2 mm (0.76 × 0.09 in.) (part no. 561 337)

In the case of threaded flange M18×1.5-6g or M22×1.5-6g, provide a screw hole based on ISO 6149-1 (Fig. 11). See ISO 6149-1 for further information.

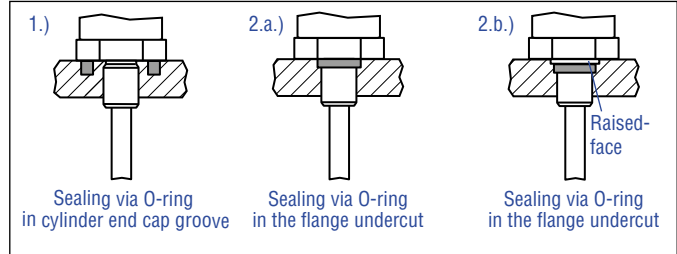

Fig. 10: Possibilities of sealing for threaded flange standard 1. + 2.a. (RH5-J/-M/-S) and for threaded flange with raised-face 2.b. (RH5-T)

- Note the fastening torque:
RH5-M: 65 Nm
RH5-S: 50 Nm
RH5-T: 55 Nm
RH5-J: 125 Nm
- Seat the flange contact surface completely on the cylinder mounting surface.
- The cylinder manufacturer determines the pressure-resistant gasket (copper gasket, O-ring, etc.).
- The position magnet should not grind on the sensor rod.
- The piston rod drilling (RH5-M/S/T-A/M/V with rod Ø 10 mm: ≥ Ø 13 mm (≥ Ø 0.51 in.); RH5-M/S/T-B with rod Ø 10 mm: ≥ Ø 16 mm (≥ Ø 0.63 in.); RH5-J-A/V with rod Ø 12.7 mm: ≥ Ø 16 mm (≥ Ø 0.63 in.)) depends on the pressure and piston speed.
- Adhere to the information relating to operating pressure.
- Protect the sensor rod against wear.

Notice for metric threaded flanges									
Thread (d ₁ ×P)	d ₂	d ₃	d ₄	d ₅ +0.1 0	L ₁ +0.4 0	L ₂	L ₃	L ₄	Z° ±1°
RH5-M-A/M/V									
M18×1.5-6g	55	≥ 13	24.5	19.8	2.4	28.5	2	26	15°
RH5-M-B									
M18×1.5-6g	55	≥ 16	24.5	19.8	2.4	28.5	2	26	15°
RH5-J-A/V									
M22×1.5-6g	55	≥ 16	27.5	23.8	2.4	28.5	2	26	15°

Controlling design dimensions are in millimeters

Fig. 11: Notice for metric threaded flange M18×1.5-6g/M22×1.5-6g based on DIN ISO 6149-1

4.4 Magnet installation

Typical use of magnets



Magnet	Typical sensors	Benefits
 Ring magnets	Rod model (RH5)	<ul style="list-style-type: none"> Rotationally symmetrical magnetic field
 U-magnets	Profile & rod models (RP5, RH5)	<ul style="list-style-type: none"> Height tolerances can be compensated, because the magnet can be lifted off
 Block magnets	Profile & rod models (RP5, RH5)	<ul style="list-style-type: none"> Height tolerances can be compensated, because the magnet can be lifted off
 Magnet sliders	Profile models (RP5)	<ul style="list-style-type: none"> The magnet is guided by the profile The distance between the magnet and the waveguide is strictly defined Easy coupling via the ball joint

Fig. 12: Typical use of magnets

Mounting ring magnets, U-magnets & block magnets

Install the magnet using non-magnetic material for mounting device, screws, spacers etc.. The magnet must not grind on the sensor rod/profile. Alignment errors are compensated via the air gap.

- Permissible surface pressure: Max. 40 N/mm² (only for ring magnets and U-magnets)
- Fastening torque for M4 screws: 1 Nm; use washers, if necessary
- Minimum distance between position magnet and any magnetic material has to be 15 mm (0.6 in.) (Fig. 15).
- If no other option exists and magnetic material is used, observe the specified dimensions (Fig. 15).

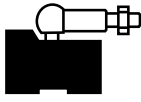
NOTICE

- Mount ring magnets and U-magnets concentrically.
- Mount block magnets centrically over the sensor rod or the sensor profile. The maximum permissible air gap must not be exceeded (Fig. 13/ Fig. 14).
- Take care to mount the primary sensor axis in parallel to the magnet path in order to avoid damage to the carriage, magnet and sensor rod/profile.

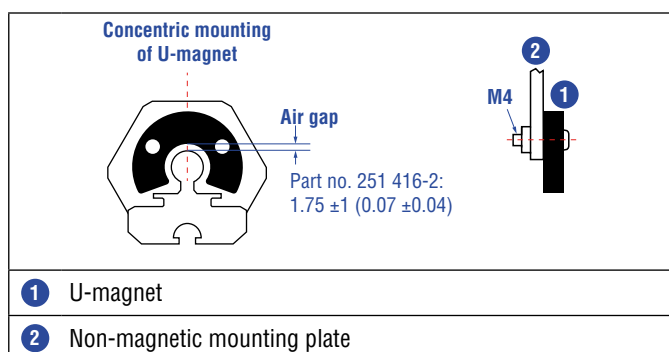

Fig. 13: Mounting of U-magnet (part no. 251 416-2)

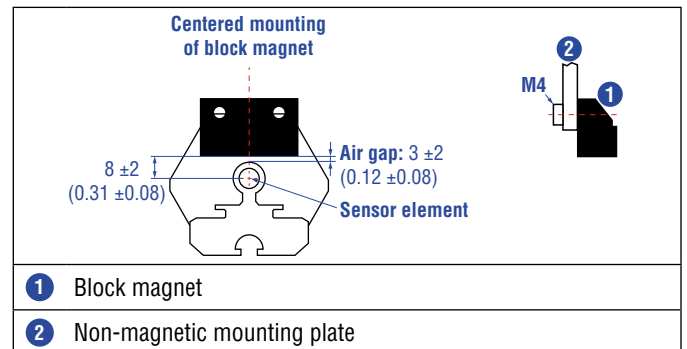

Fig. 14: Mounting of block magnet (part no. 403 448)

Magnet mounting with magnetic material

When using magnetic material the dimensions of Fig. 15 must be observed.

- A.** If the position magnet aligns with the drilled piston rod
- B.** If the position magnet is set further into the drilled piston rod, install another non-magnetic spacer (e.g. part no. 400 633) above the magnet.

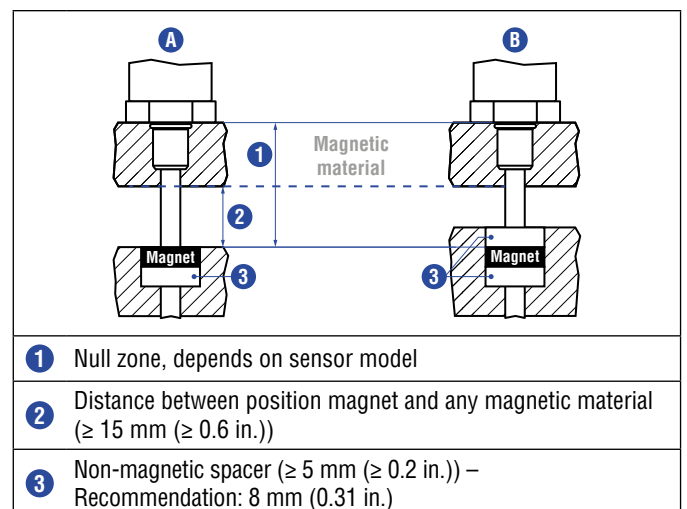

Fig. 15: Installation with magnetic material

Sensors with stroke lengths ≥ 1 meter (3.3 ft.)

Support horizontally installed sensors with a stroke length from 1 meter (3.3 ft.) mechanically at the rod end. Without using a support, the sensor rod bends over and the rod and the position magnet may be damaged. A false measurement result is also possible. Longer rod require evenly distributed mechanical support over the entire length (e.g. part no. 561 481). Use an U-magnet (Fig. 16) for measurement.

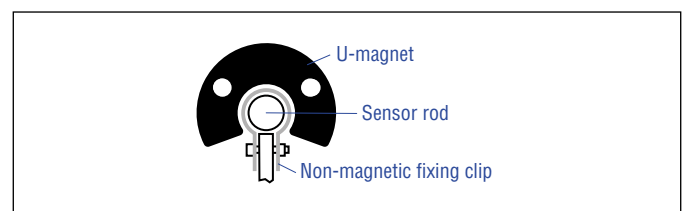

Fig. 16: Example of sensor support (part no. 561 481)

Controlling design dimensions are in millimeters and measurements in () are in inches

Start- and end positions of the position magnets

Consider the start and end positions of the position magnets during the installation. To ensure that the entire stroke length is electrical-ly usable, the position magnet must be mechanically mounted as fol-lows.

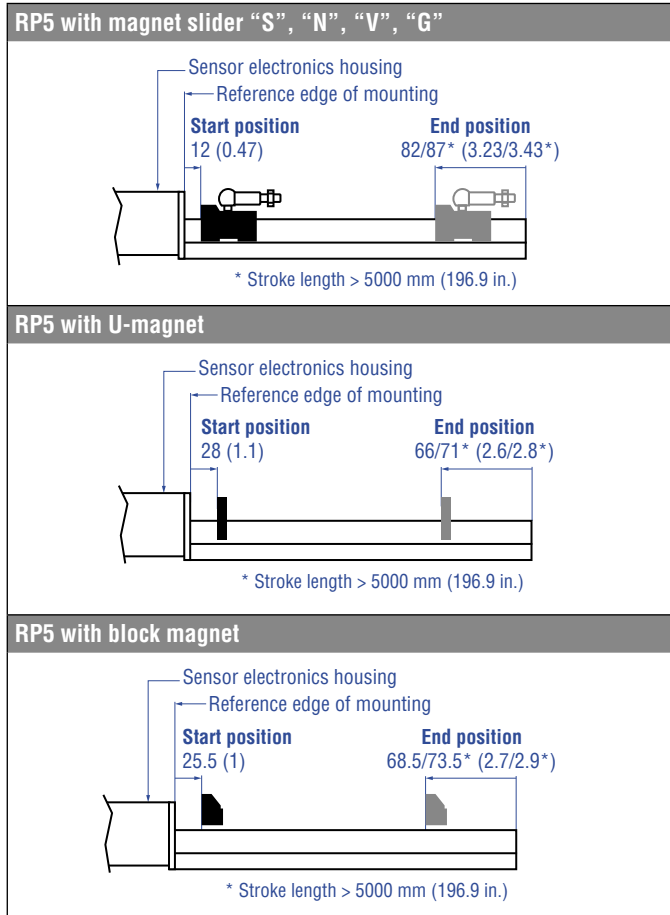

Fig. 17: Start- & end positions of magnets for RP5

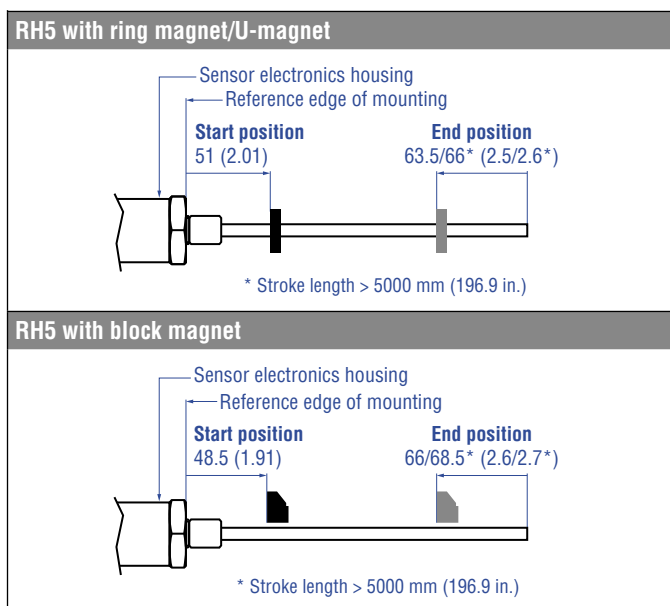

Fig. 18: Start- & end positions of magnets for RH5

NOTICE
On all sensors, the areas left and right of the active stroke length are provided for null and dead zone. These zones should not be used for measurement, however the active stroke length can be exceeded.

Differential measurement

For a differential measurement two positions are measured on the sensor rod or sensor profile. The distance between these positions will be output.

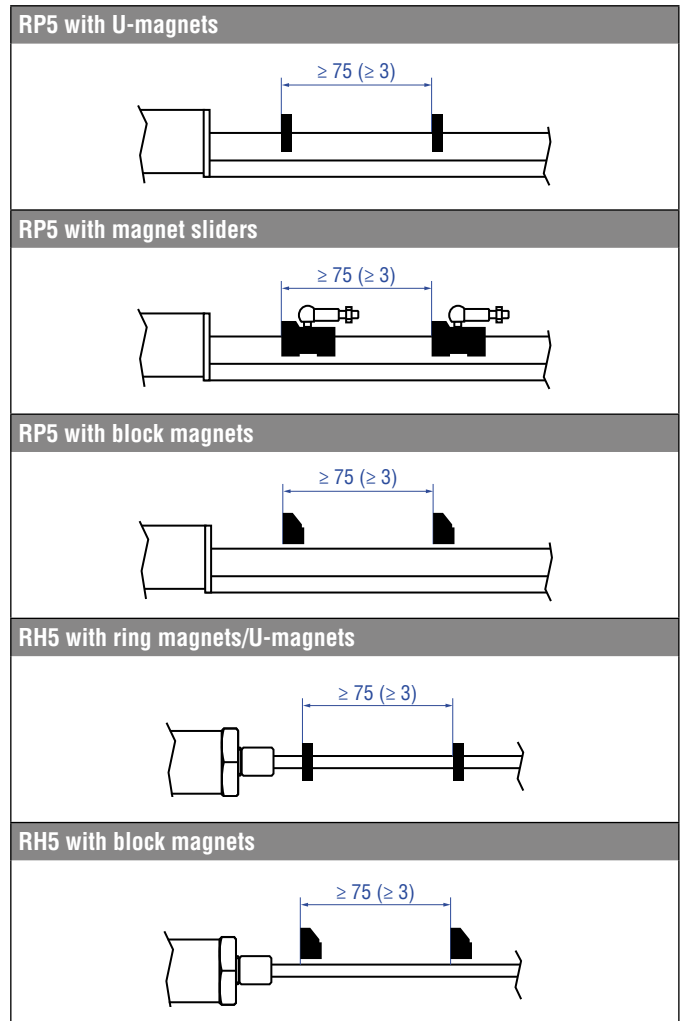

Fig. 19: Minimum distance between magnets for differential measurement

NOTICE
Do not go below a minimal distance of 75 mm (3 in.) between the magnets for differential measurement³. Use magnets of the same type (e.g. 2 x U-magnet, part no. 251 416-2) for differential measurement.

³ Controlling design dimensions are in millimeters and measurements in () are in inches
³ Contact MTS Sensors if you need a magnet distance, which is smaller than 75 mm (3 in.).

4.5 Alignment of the magnet with the option “Internal linearization”

The internal linearization offers improved linearity of the sensor. The option must be specified in the order code of the sensor. The internal linearization is set for the sensor during production.

A sensor with internal linearization is delivered with the magnet with which the sensor was aligned during production. In order to achieve the best possible result, MTS Sensors recommends to operate the sensor with the supplied magnet.

For the internal linearization, the following magnets can be used:

- Ring magnet OD33 (part no. 253 620), only for RH5
- U-magnet OD33 (part no. 254 226)
- Ring magnet OD25.4 (part no. 253 621), only for RH5
- Magnet slider S (part no. 252 182), only for RP5
- Magnet slider N (part no. 252 183), only for RP5
- Magnet slider V (part no. 252 184), only for RP5
- Magnet slider G (part no. 253 421), only for RP5

The ring magnet and U-magnet will be marked for the internal linearization. During the installation, the magnets have to be aligned to the sensor electronic housing, see Fig. 20, Fig. 21 and Fig. 22.

For RH5 SSI sensors with ring magnet applies:

- Install the magnet until the marking on the magnet points to the sensor electronics housing.
- The marking on the magnet points to the same direction as the screw in the lid of the sensor electronics housing, which is located right of the status LED.

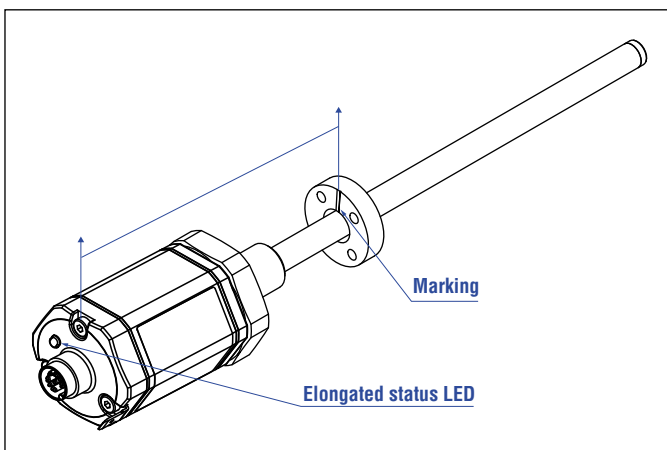

Fig. 20: Alignment of ring magnet for RH5 SSI with internal linearization

For RP5 SSI sensors with U-magnet applies:

- Install the magnet until the marking on the magnet points to the sensor electronics housing.
- The marking on the magnet points to the same direction as the screw in the lid of the sensor electronics housing, which is located right of the status LED.

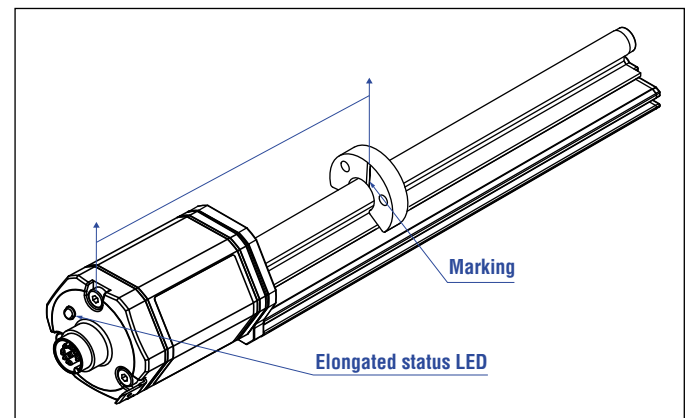

Fig. 21: Magnet alignment of U-magnet for RP5 SSI with internal linearization

For RP5 SSI sensors with magnet slider applies:

- 1 Install the magnet sliders “S”, “N” and “G” until the additional hole in the magnet points towards the sensor electronics housing.
- 2 Install the magnet slider “V” until the joint points to the end of the profile.

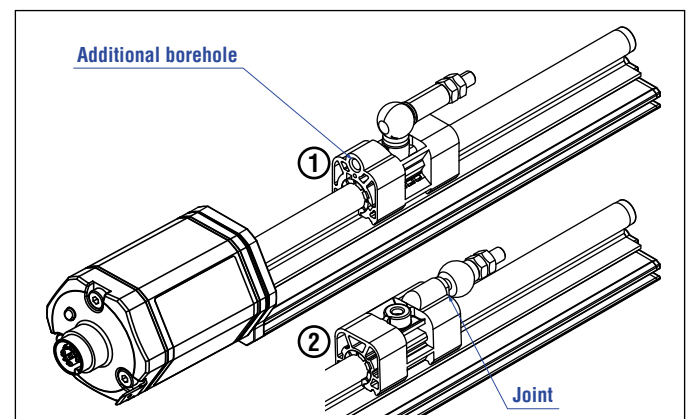

Fig. 22: Magnet alignment of magnet slider for RP5 SSI with internal linearization

The internal linearization of the sensor is carried out under the following conditions:

- Supply voltage +24 VDC ±0.5
- Operating time > 30 min
- No shock and no vibration
- Eccentricity of the position magnet to central axis of the sensor < 0.1 mm

NOTICE

The generated linearization might deviate from the linearity tolerances regarding different environmental conditions. In addition, the use of a different position magnet or more position magnets may cause differences.

4.6 Replacement of base unit

The base unit of the sensor model RH5 (RH5-B) is replaceable as shown in Fig. 23 and Fig. 24 for the sensor designs »M«, »S« and »T«. The sensor can be replaced without interrupting the hydraulic circuit.

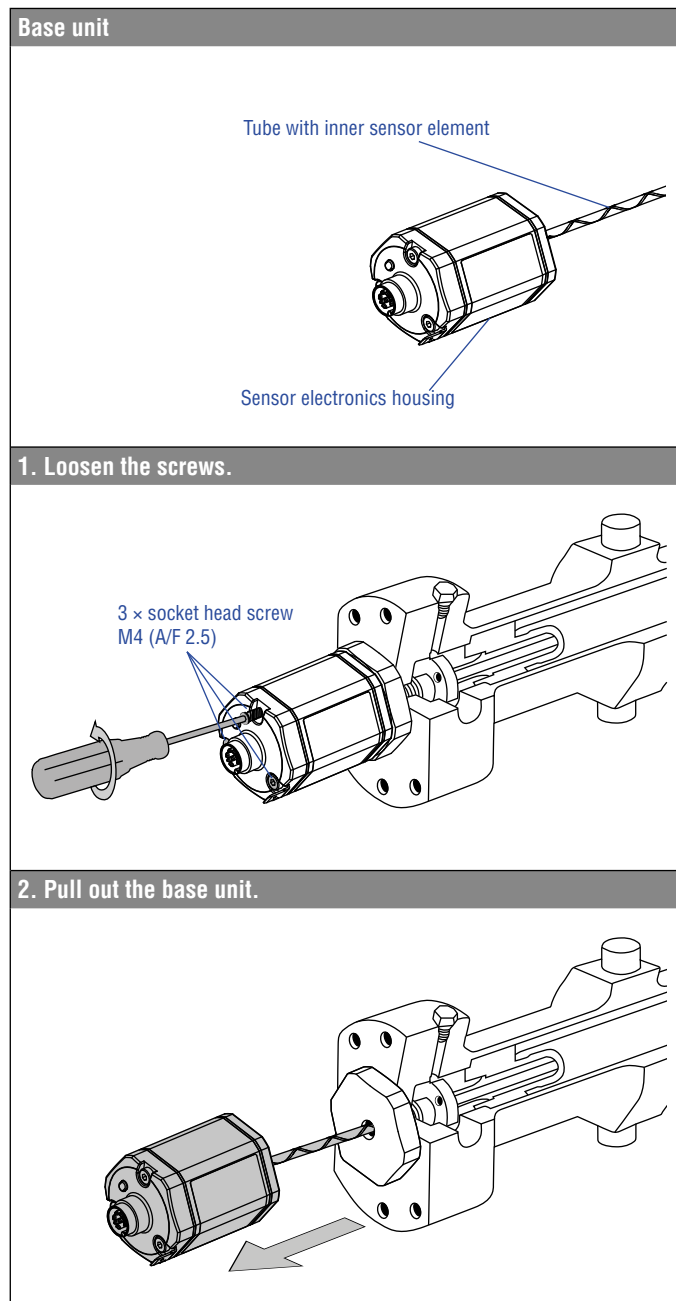

Fig. 23: Replacement of the base unit (e.g. RH5 sensor), part 1

3. Insert the new base unit.
Install the ground lug on a screw.
Tighten the screws.

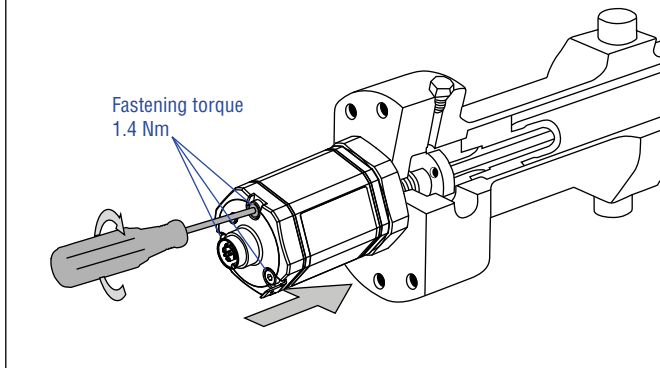

Fig. 24: Replacement of the base unit (e.g. RH5 sensor), part 2

NOTICE

- If the R-Series V replaces a predecessor model of the R-Series, the plastic tube in the sensor rod must be removed.
- When replacing the base unit, make sure that no humidity enters the sensor tube. This may damage the sensor.
- Secure the base unit screws, e.g. using Loctite 243, before re-installing.

4.7 Electrical connection

Placement of installation and cabling have decisive influence on the sensor's electromagnetic compatibility (EMC). Hence correct installation of this active electronic system and the EMC of the entire system must be ensured by using suitable metal connectors, shielded cables and grounding. Overvoltages or faulty connections can damage its electronics despite protection against wrong polarity.

NOTICE

1. Do not mount the sensors in the area of strong magnetic or electric noise fields.
2. Never connect/disconnect the sensor when voltage is applied.

Instructions for connection

- Use low-resistant twisted pair and shielded cables. Connect the shield to ground externally via the control system equipment.
- Keep control and signal cables separate from power cables and sufficiently far away from motor cables, frequency inverters, valve lines, relays, etc..
- Use only connectors with metal housing and connect the shielding to the connector housing.
- Keep the connection surface at both shielding ends as large as possible. Connect the cable clamps to function as a ground.
- Keep all non-shielded leads as short as possible.
- Keep the earth connection as short as possible with a large cross section. Avoid ground loops.
- With potential differences between machine and electronics earth connections, no compensating currents are allowed to flow across the cable shielding.

Recommendation:

Install potential compensating leads with large cross section, or use cables with separate double shielding, and connect only one end of the shield.

- Use only stabilized power supplies in compliance with the specified electrical ratings.

Grounding of profile and rod sensors

Connect the sensor electronics housing to machine ground. Ground sensor types RP5 and RH5 via ground lug as shown in Fig. 25. In addition you can ground the sensor type RH5 via thread.

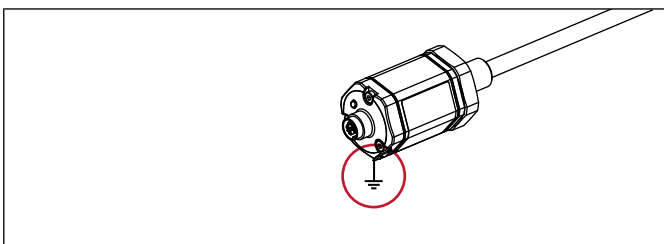

Fig. 25: Grounding via ground lug (e.g. RH5)

Connector wiring

Connect the sensor directly to the control system, indicator or other evaluating systems as follows:

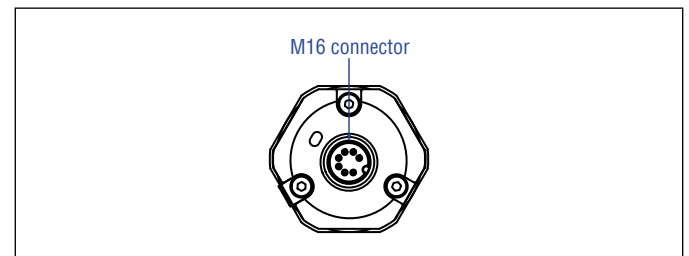

Fig. 26: Location of connection (example connector output)

D70		
Signal + power supply		
M16 male connector	Pin	Function
<p>View on sensor</p>	1	Data (-)
	2	Data (+)
	3	Clock (+)
	4	Clock (-)
	5	+12...30 VDC ($\pm 20\%$)
	6	DC Ground (0 V)
	7	Not connected

Fig. 27: Connector wiring D70

HXX / PXX / RXX / TXX		
Signal + power supply		
Cable	Color	Function
	GY	Data (-)
	PK	Data (+)
	YE	Clock (+)
	GN	Clock (-)
	BN	+12...30 VDC ($\pm 20\%$)
	WH	DC Ground (0 V)

For cable type TXX, the extra red & blue wires are not used.

Fig. 28: Connector wiring cable output

4.8 Frequently ordered accessories for sensor model RP5 – Additional options available in our [Accessories Guide](#) 551 444

Position magnets

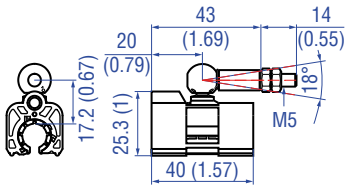

Magnet slider S, joint at top
Part no. 252 182

Material: GRP, magnet hard ferrite
Weight: Approx. 35 g
Operating temperature:
-40...+85 °C (-40...+185 °F)

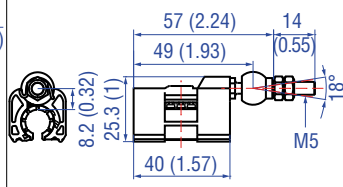

Magnet slider V, joint at front
Part no. 252 184

Material: GRP, magnet hard ferrite
Weight: Approx. 35 g
Operating temperature:
-40...+85 °C (-40...+185 °F)

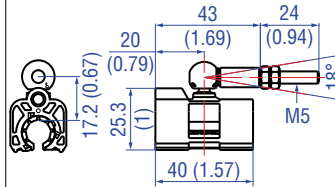

**Magnet slider N
longer ball-joint arm**
Part no. 252 183

Material: GRP, magnet hard ferrite
Weight: Approx. 35 g
Operating temperature:
-40...+85 °C (-40...+185 °F)

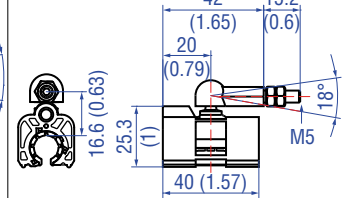

Magnet slider G, backlash free
Part no. 253 421

Material: GRP, magnet hard ferrite
Weight: Approx. 25 g
Operating temperature:
-40...+85 °C (-40...+185 °F)

Position magnets

Mounting accessories

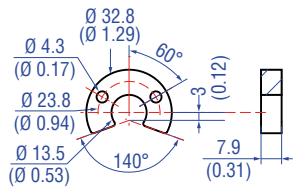

U-magnet OD33
Part no. 251 416-2

Material: PA ferrite GF20
Weight: Approx. 11 g
Surface pressure: Max. 40 N/mm²
Fastening torque for M4 screws: 1 Nm
Operating temperature:
-40...+105 °C (-40...+221 °F)

Marked version for sensors with inter-
nal linearization: Part no. 254 226

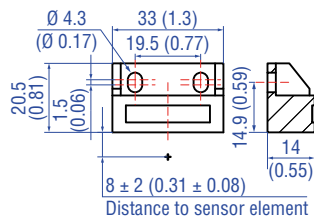

Block magnet L
Part no. 403 448

Material: Plastic carrier with hard ferrite
magnet
Weight: Approx. 20 g
Fastening torque for M4 screws: 1 Nm
Operating temperature:
-40...+75 °C (-40...+167 °F)

This magnet may influence the sensor
performance specifications for some
applications.

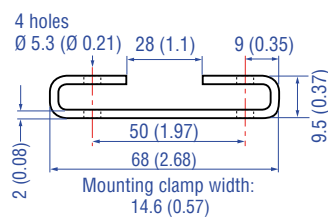

Mounting clamp
Part no. 400 802

Material: Stainless steel (AISI 304)

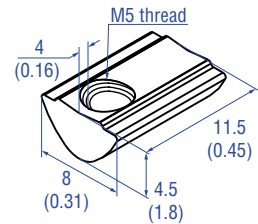

T-nut
Part no. 401 602

Fastening torque for M5 screw: 4.5 Nm

4.9 Frequently ordered accessories for sensor model RH5 – Additional options available in our [Accessories Guide](#) 551 444

Position magnets

<p>U-magnet OD33 Part no. 251 416-2</p> <p>Material: PA ferrite GF20 Weight: Approx. 11 g Surface pressure: Max. 40 N/mm² Fastening torque for M4 screws: 1 Nm Operating temperature: -40...+105 °C (-40...+221 °F)</p> <p>Marked version for sensors with internal linearization: Part no. 254 226</p>	<p>Ring magnet OD33 Part no. 201 542-2</p> <p>Material: PA ferrite GF20 Weight: Approx. 14 g Surface pressure: Max. 40 N/mm² Fastening torque for M4 screws: 1 Nm Operating temperature: -40...+105 °C (-40...+221 °F)</p> <p>Marked version for sensors with internal linearization: Part no. 253 620</p>	<p>Ring magnet OD25.4 Part no. 400 533</p> <p>Material: PA ferrite Weight: Approx. 10 g Surface pressure: Max. 40 N/mm² Operating temperature: -40...+105 °C (-40...+221 °F)</p> <p>Marked version for sensors with internal linearization: Part no. 253 621</p>	<p>Ring magnet Part no. 402 316</p> <p>Material: PA ferrite coated Weight: Approx. 13 g Surface pressure: Max. 20 N/mm² Operating temperature: -40...+100 °C (-40...+212 °F)</p>



Position magnet Magnet spacer O-rings

<p>Block magnet L Part no. 403 448</p> <p>Material: Plastic carrier with hard ferrite magnet Weight: Approx. 20 g Fastening torque for M4 screws: 1 Nm Operating temperature: -40...+75 °C (-40...+167 °F)</p> <p>This magnet may influence the sensor performance specifications for some applications.</p>	<p>Magnet spacer Part no. 400 633</p> <p>Material: Aluminum Weight: Approx. 5 g Surface pressure: Max. 20 N/mm² Fastening torque for M4 screws: 1 Nm</p>	<p>O-ring for threaded flange M18×1.5-6g Part no. 401 133</p> <p>Material: Fluoroelastomer Durometer: 75 ± 5 Shore A Operating temperature: -40...+204 °C (-40...+400 °F)</p>	<p>O-ring for threaded flange ¾"-16 UNF-3A Part no. 560 315</p> <p>Material: Fluoroelastomer Durometer: 75 ± 5 Shore A Operating temperature: -40...+204 °C (-40...+400 °F)</p>

O-ring Mounting accessories

<p>O-ring for threaded flange M22×1.5-6g Part no. 561 337</p> <p>Material: FPM Durometer: 75 Shore A Operating temperature: -20...+200 °C (-6...+392 °F)</p>	<p>Hex jam nut M18×1.5-6g Part no. 500 018</p> <p>Material: Steel, zinc plated</p>	<p>Hex jam nut ¾"-16 UNF-3A Part no. 500 015</p> <p>Material: Steel, zinc plated</p>	<p>Fixing clip Part no. 561 481</p> <p>Application: Used to secure sensor rods (Ø 10 mm (Ø 0.39 in.)) when using an U-magnet or block magnet Material: Brass, non-magnetic</p>

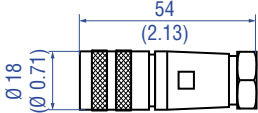
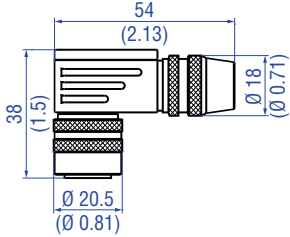
4.10 Frequently ordered accessories for SSI output – Additional options available in our [Accessories Guide](#) 551 444

Cable connectors*	Programming tool	
		
<p>M16 female connector (7 pin), straight Part no. 370 624</p>	<p>M16 female connector (7 pin), angled Part no. 560 779</p>	<p>TempoLink kit for Temposonics® R-Series V Part no. TL-1-0-SD70 (for D70) Part no. TL-1-0-AS00 (for cable output)</p>
<p>Material: Zinc nickel plated Termination: Solder Contact insert: Silver plated Cable clamp: PG9 Cable Ø: 6...8 mm (0.24...0.31 in.) Operating temperature: -40...+100 °C (-40...+212 °F) Ingress protection: IP65/IP67 (correctly fitted) Fastening torque: 0.7 Nm</p>	<p>Material: Zinc nickel plated Termination: Solder Contact insert: Silver plated Cable clamp: PG9 Cable Ø: 6...8 mm (0.24...0.31 in.) Operating temperature: -40...+100 °C (-40...+212 °F) Ingress protection: IP65/IP67 (correctly fitted) Fastening torque: 0.7 Nm</p>	<ul style="list-style-type: none"> • Connect wirelessly via Wi-Fi enabled device or via USB with the diagnostic tool • Simple connectivity to the sensor via 24 VDC power line (permissible cable length: 30 m) • User friendly interface for mobile devices and desktop computers • See data sheet "TempoLink smart assistant" (document part no.: 552070) for further information

Cables

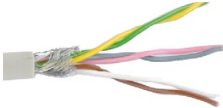
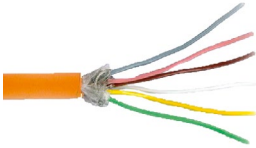
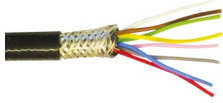
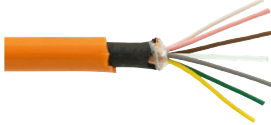
			
<p>PVC cable Part no. 530 032</p>	<p>PUR cable Part no. 530 052</p>	<p>Teflon® cable Part no. 530 112</p>	<p>PUR cable Part no. 530 175</p>
<p>Material: PVC jacket; gray Features: Twisted pair, shielded, flexible Cable Ø: 6 mm (0.23 in.) Cross section: 3 × 2 × 0.14 mm² Bending radius: 10 × D (fixed installation) Operating temperature: -40...+105 °C (-40...+221 °F)</p>	<p>Material: PUR jacket; orange Features: Twisted pair, shielded, highly flexible, halogen free, energy chain capable, mostly oil & flame resistant Cable Ø: 6.4 mm (0.25 in.) Cross section: 3 × 2 × 0.25 mm² Bending radius: 5 × D (fixed installation) Operating temperature: -30...+80 °C (-22...+176 °F)</p>	<p>Material: Teflon® jacket; black Features: Twisted pair, shielded, flexible, high thermal resistance, mostly oil & acid resistant Cable Ø: 7.6 mm (0.3 in.) Cross section: 4 × 2 × 0.25 mm² Bending radius: 8 – 10 × D (fixed installation) Operating temperature: -100...+180 °C (-148...+356 °F)</p>	<p>Material: PUR jacket; orange Features: Flexible, additional EMC protection Cable Ø: 6.5 mm (0.26 in.) Cross section: 6 × 0.14 mm² Bending radius: 10 × D (fixed installation) Operating temperature: -30...+90 °C (-22...+194 °F)</p>

*/ Follow the manufacturer's mounting instructions

Controlling design dimensions are in millimeters and measurements in () are in inches

5. Commissioning

5.1 Introduction

SSI

The synchronous-serial interface (SSI) is a digital interface that enables serial transmission. Data is transmitted from the device to the connected control system synchronously to a clock rate specified by the control system. The interface of Temposonics® position sensors corresponds to SSI industry standard for absolute encoders. Its displacement value is encoded in a 24/25/26 bit binary or gray format and transmitted as a differential signal in SSI standard (RS-485/RS-422) – independent of data width of the code (resolution). The absolute, parallel position data is continually updated by the sensor and converted by the shift-register into a serial bit stream. Dependent on the baud rate chosen in the control system the following cable lengths are possible:

Cable length	< 3 m	< 50 m	< 100 m	< 200 m	< 400 m
Baud rate	1 MBd	< 400 kBd	< 300 kBd	< 200 kBd	< 100 kBd

Fig. 29: Cable lengths and related baud rates

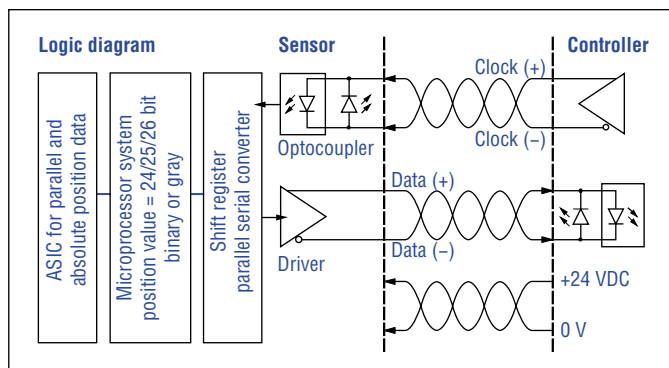

Fig. 30: Schematic connection

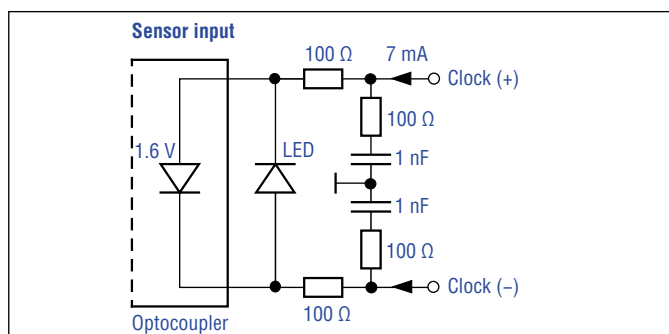

Fig. 31: Input wiring clock (+)/clock (-)

The data is transferred serially at SSI, whereby the control system determines the time of the polling. During data transmission, the procedure described below is carried out (Fig. 32):

1. In the idle state, when no data is transmitted, the data line and the clock line are at high level. ①
2. The current position data is frozen in the shift register with the first falling clock edge. It is no longer possible to update the position data in this cycle. ②
3. The bit is applied at the following rising edge. ③
4. With the following falling edge, the transmission of the data begins with the **Most Significant Bit (MSB)**. ④
5. This is repeated for each next lower bit until the **Last Significant Bit (LSB)** is transmitted.
6. The standard one shot starts after the last falling clock edge ⑤. After the transmission of the LSB, the data line remains on the low level and the clock line on the high level until the end of the standard one shot. Then the sensor is ready for the transmission of a new data ⑥.

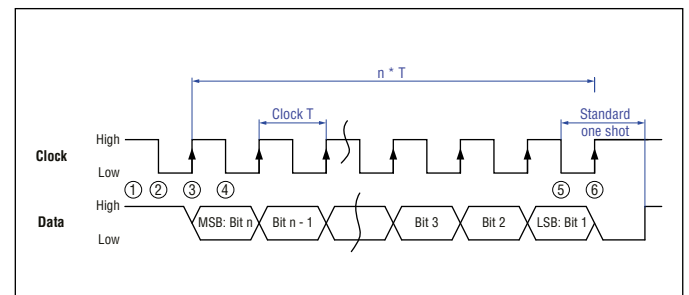
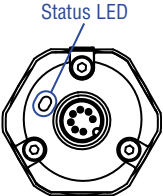

Fig. 32: Timing diagram

5.2 LED status

The LED on the sensor visualizes the current sensor status. In normal function the LED is continuously green. In other cases the color of the LED changes in the time slot of 0.5 seconds as shown in Fig. 33.

R-Series V SSI LED status				
				
Time slot 1	Time slot 2	Time slot 3	Time slot 4	Information
GN	GN	GN	GN	Normal function
RD + GN	RD + GN	RD + GN	RD + GN	Magnet status error
BU + GN	BU + GN	BU + GN	BU + GN	Sync status error
RD	Off	RD	Off	Power supply error
BU	Off	BU	Off	Command Mode
GN	RD	BU	Off	Extra magnet
GN	Off	GN	Off	Cycle timeout
GN	BU	RD	Off	Configuration error
BU	GN	RD	Off	Storage error
BU	RD	GN	Off	Internal error
RD	BU	GN	Off	Signal error
RD	GN	BU	Off	Position error

1 × time slot = 0.5 seconds

Fig. 33: LED status

Fig. 34 describes error conditions that are output via the LEDs and troubleshooting.

Error condition	Description	Troubleshooting
Magnet status error	Sensor registers less position magnets than set	Ensure that the number of position magnets on the sensor matches the set number.
Sync status error	Sensor cannot synchronize to the external clock of the control system	Adjust the parameter "Jitter Window". Reduce the clock rate of the polling cycle at the control system. Ensure that the control system operates in synchronous mode.
Power supply error	Power supply of the sensor is out of the allowable range	Set the power supply for the sensor to the allowable range.
Extra magnet	Sensor registers more position magnets than set	Ensure that the number of position magnets on the sensor matches the set number.
Cycle timeout	In synchronous mode, the sensor does not receive the clock for the polling cycle	Ensure that the clock of the control system arrives at the sensor. Ensure that the control system operates in synchronous mode.
Configuration error	Invalid configuration of the sensor	Check the configuration of the sensor. Contact MTS Sensors.
Storage error	Error in internal data storage	Contact MTS Sensors.
Internal error	Internal error of the sensor	Contact MTS Sensors.
Signal error	Internal signal error	Contact MTS Sensors.
Position error	Error in position measurement	Contact MTS Sensors.

Fig. 34: Error conditions and troubleshooting

NOTICE

Observe during commissioning

1. Before initial switch-on, check carefully if the sensor has been connected correctly.
2. Position the magnet in the measuring range of the sensor during first commissioning and after replacement of the magnet.
3. Ensure that the sensor control system cannot react in an uncontrolled way when switching on.
4. Ensure that the sensor is ready and in operation mode after switching on. The status LED lights permanently green.
5. Check the preset span start and end values of the measuring range (see chapter 4.4) and correct them via the TempoLink smart assistant, if necessary.

5.3 Programming and configuration

5.3.1 Connection of TempoLink smart assistant to R-Series V sensor

The TempoLink smart assistant can be connected to all R-Series V sensors. The adapter cable connects the TempoLink smart assistant to a R-Series V sensor. If the sensor is connected to a control system, disconnect the sensor from that control system before connecting the TempoLink smart assistant to the sensor.

Connect the barrel connector of the adapter cable to the connection point labeled "OUTPUT SENSOR" on the TempoLink smart assistant (Fig. 35).

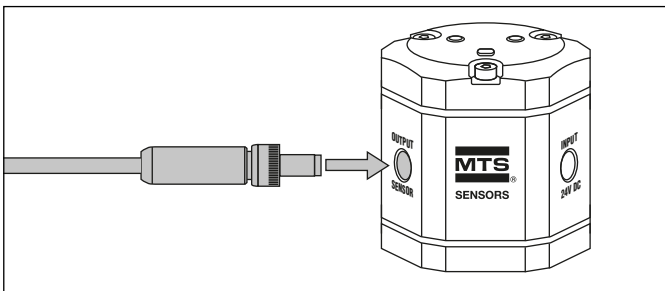

Fig. 35: Connection of adapter cable to TempoLink smart assistant

NOTICE

- When disconnecting the power supply of the sensor, possibly error messages occur at the connected control system.
- Do not exceed the maximum cable length between TempoLink smart assistant and R-Series V sensor of 30 m (99 ft.).

1. Connection to a sensor with connector output

Connect the other end of the adapter cable to the R-Series V. The sensor is powered by the TempoLink smart assistant (Fig. 36).

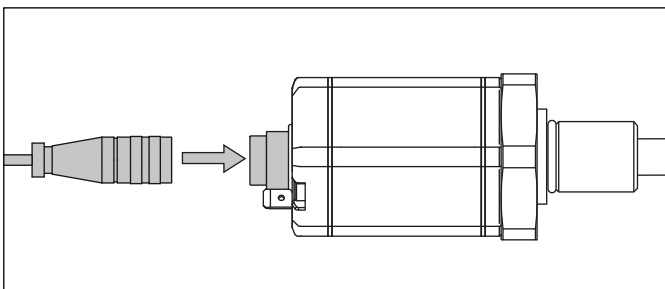

Fig. 36: Connection of adapter cable to R-Series V sensor with connector output

2. Connection to a sensor with cable output

Connect the pig-tails of the sensor cable to the terminal clamps of the adapter cable according to the connector wiring in Fig. 37 (Fig. 38).

Color sensor cable	Color adapter cable	Function
GY	GY	–
PK	PK	–
YE	YE	–
GN	GN	–
BN	BN	+ 24 VDC
WH	WH	DC Ground (0 V)

Fig. 37: Connection of adapter cable to sensor cable

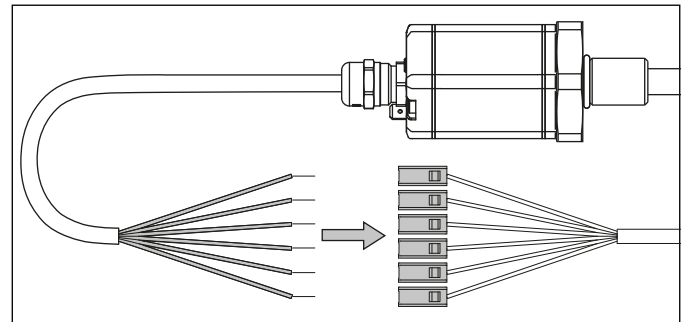

Fig. 38: Connection of adapter cable to R-Series V sensor with cable output

5.3.2 Connection of TempoLink smart assistant to power supply

Connect the barrel connector of the power supply to the connection point labeled “INPUT 24 VDC” on the TempoLink smart assistant (Fig. 39).

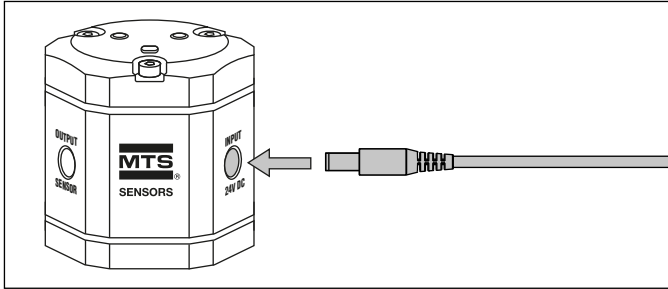

Fig. 39: Connection of power supply to the TempoLink smart assistant

There are two ways to connect the TempoLink smart assistant to a power supply:

1. Connection via the plug-in power supply with plug adapters

Attach the plug attachment suitable for your country to the plug. Insert the plug into the outlet (Fig. 40).

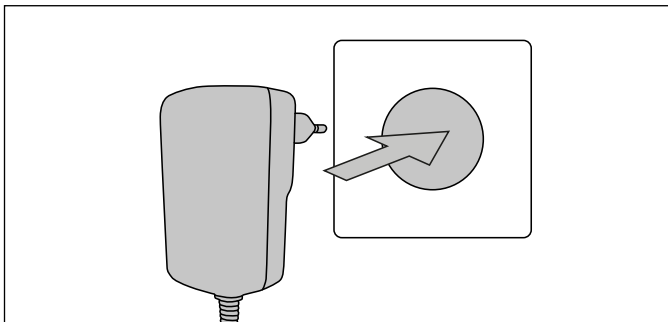

Fig. 40: Connection of the plug-in power supply to the outlet

2. Connection via the cable with barrel connector and pig-tail

Connect the cable to a power supply according to the connector wiring in Fig. 41 (Fig. 42).

Cable	Function
● RD	+24 VDC
● BK	DC Ground (0 V)

Fig. 41: Connector wiring cable

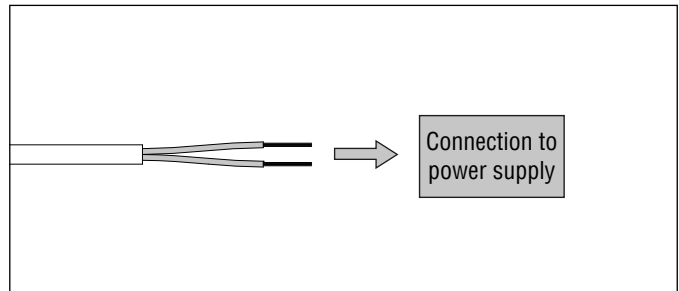

Fig. 42: Connection of cable with barrel connector and pig-tails

5.3.3 Connection of TempoLink smart assistant to smartphone, tablet or computer

Connect to a smartphone, tablet or computer to display the graphical user interface of the TempoLink smart assistant.

Connecting a Wi-Fi enabled device to the integrated Wi-Fi access point ⁴

Activate Wi-Fi on the device and choose the network “TempoLink_XXXX” (XXXX indicates the last four digits of the serial number). The access to the Wi-Fi network is password protected. The default password is the serial number printed on the label on the bottom of the TempoLink smart assistant.

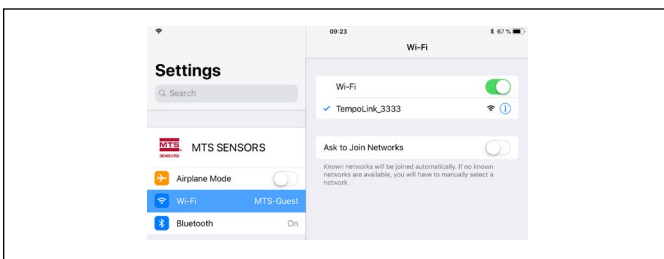

Fig. 43: Choose the network “TempoLink_XXXX” in the Wi-Fi settings of the Wi-Fi-enabled device

NOTICE

If you are using a mobile device, ensure cellular data is off. Depending on your operation system, message can appear, that there is no internet access. TempoLink smart assistant does not need internet access. Connecting to the user interface may take longer if Wi-Fi and cellular data are active.

Connecting a computer via USB connection

The TempoLink smart assistant can also be connected via USB. If the computer is Wi-Fi enabled deactivate Wi-Fi on the computer before setting up the USB connection.

1. Connect the USB cable with the micro USB connector to the port labeled “USB” on the TempoLink smart assistant (Fig. 44).
2. Next, connect the USB type-A connector to a free USB port of the computer. The USB connection simulates a network card. In the folder “network connections” on the computer the connection is shown as “IP-over-USB” or “Remote NDIS”.

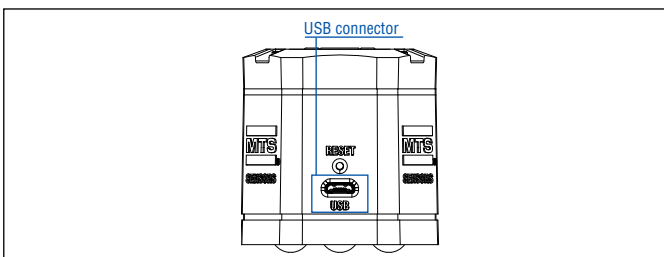

Fig. 44: USB port on the TempoLink smart assistant

NOTICE

Only one device can be connected to the TempoLink smart assistant at a time in order to display the graphical user interface.

NOTICE

Disable all Wi-Fi and LAN connections before connecting TempoLink smart assistant via USB. Connecting to the user interface may take longer if Wi-Fi and LAN connections are active. Should the website do not build up, it may be useful to press CTRL + F5 to delete cached text and images from prior to launching the <http://tempolink.local> website.

5.3.4 Establishing a connection via browser

After the connection via Wi-Fi or USB is established, open the browser on your mobile device or computer and go to the website-URL: <http://tempolink.local>

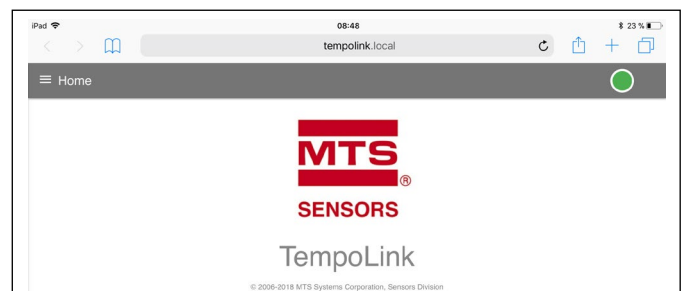

Fig. 45: Main menu of the graphical user interface

Connection status

Green	Information
● ON	Connection to sensor is established
Red	Information
● ON	Connection to sensor is not established
Blue	Information
● ON	Sensor in command mode

Fig. 46: Connection status

^{4/} The integrated Wi-Fi access point does not provide internet access.

5.3.5 Graphical user interface

Click the menu symbol  in the top left to get to the main menu of the graphical user interface (GUI) (Fig. 47):

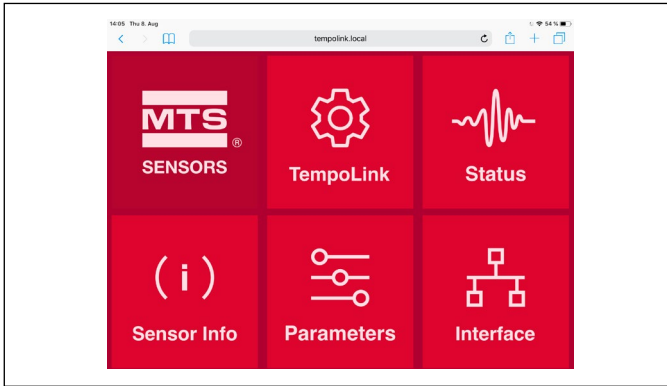

Fig. 47: Main menu of the graphical user interface

NOTICE

Read the TempoLink smart assistant operation manual (document part number: [551986](#)) for more information.

TempoLink: Includes information about the TempoLink smart assistant.

Status: Includes information about the sensor status.

Sensor Info: Includes information about the connected sensor.

Parameters: Includes information about the operational settings of the connected sensor (Fig. 48).

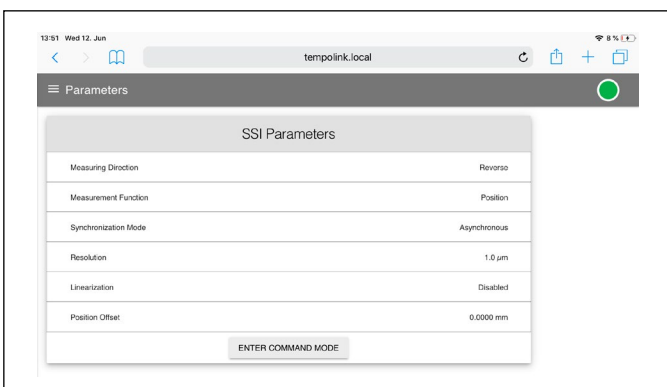

Fig. 48: SSI parameters

To change parameters or to reset the sensor to factory settings, the command mode must be started. In command mode, the sensor does not output a position value. By clicking the button “ENTER COMMAND MODE” the “Enter Command Mode” window opens. After reading the information, enter the word COMMAND and confirm by clicking “OK” (Fig. 49).

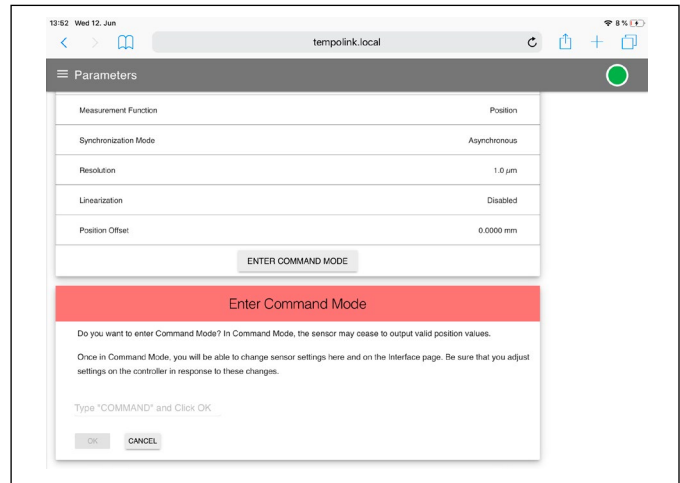



Fig. 49: Starting the command mode to change parameters of the connected sensor

After entering the command mode the connection icon on the top right will turn from green to blue. The status LED of the sensor also flashes blue. A pencil icon  will appear to the right of parameter values. By clicking the pencil icon a new menu for configuring the parameters will open. Change the parameter and confirm it by clicking the “SUBMIT” button (Fig. 50).

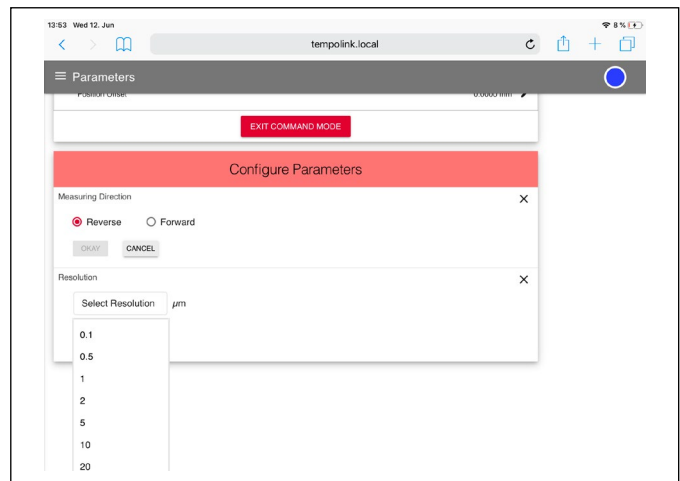

Fig. 50: Configuration of SSI parameters

Measuring Direction: Setting the measuring direction for position measurement.

- Forward
- Reverse

Measurement Function: Setting the function of the measurement.

- Position
- Velocity
- Differential

Synchronization Mode: Setting the type of synchronization for the position measurement.

- Asynchronous
- Synchronous mode 1
- Synchronous mode 2
- Synchronous mode 3

Resolution: Setting the resolution of the position measurement.

Linearization: Setting the internal linearization.

- Enabled

NOTICE “Enabled” can only be activated if the sensor was ordered with the option “internal linearization”.

- Disabled

Filter Configuration: Setting of the filter for the output value.

Filter Type: Setting the filter type.

- None: No filter (default value)
- FIR (Finite Impulse Response Filter)
- IIR (Infinite Impulse Response Filter)

Filter Window Size: Setting of position values for calculating the filter of the output value.

By clicking the button “FACTORY RESET” the sensor is reset to the factory setting. After the parameters have been configured or the factory reset has been carried out, click the “EXIT COMMAND MODE” button. A new menu for exiting the command mode will open (Fig. 51). Click the “SAVE AND EXIT” button to exit the command mode and to transfer the changed parameters to the sensor. The sensor returns to the normal function and outputs the current position value. The connection icon on the top right will turn to green. The status LED of the sensor flashes green.

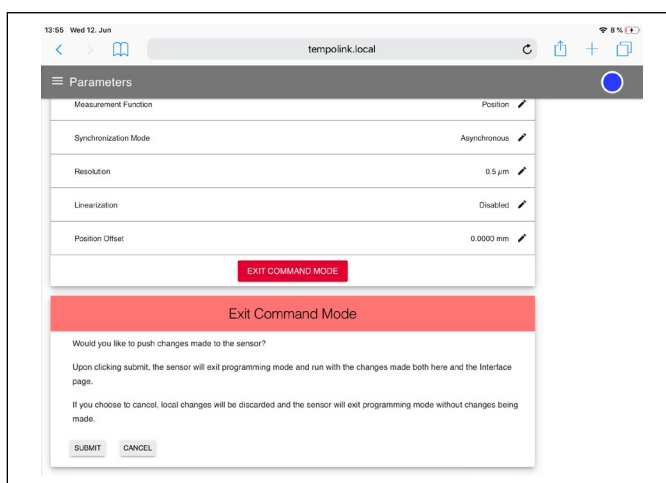

Fig. 51: Exit the command mode

NOTICE

Changes to the sensor parameters must also be set to the control system.

Different parameter values on sensor and control system can lead to unpredictable behavior of the control system.

Interface: Includes information about the interface settings of the connected sensor (Fig. 52).

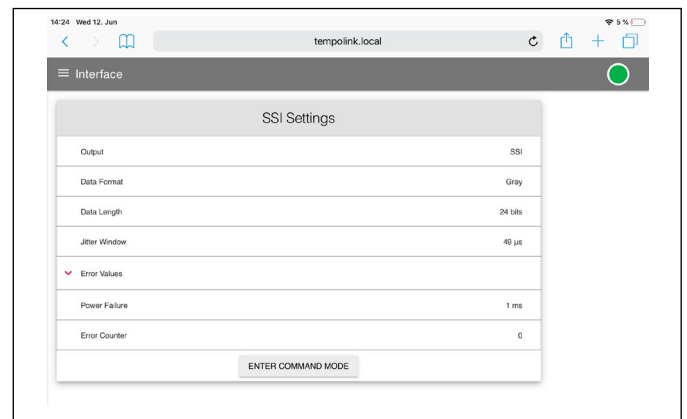



Fig. 52: Configuration of SSI settings

To change interface settings, start the command mode (page 28). After entering the command mode a pencil icon  will appear to the right of the setting values. By clicking the pencil icon a new menu for configuring the settings will open. Change the parameter and confirm it by clicking the “SUBMIT” button (Fig. 53).

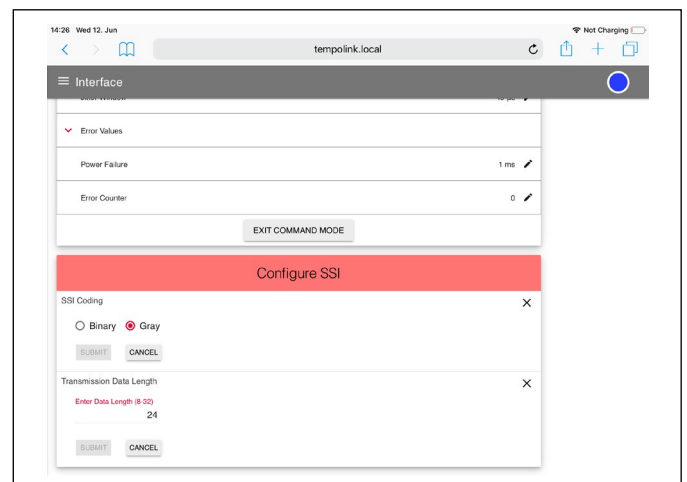

Fig. 53: Configuration of SSI settings

Data Format: Setting the SSI coding for the data transmission.

Data Length: Setting the bit width for the data transmission.

Jitter Window: The jitter specifies the time interval between the start of measuring and the SSI clock, which is given by the PLC (for synchronous mode). Values between 0...255 μ s can be set for this parameter (default value: 50 μ s). A larger value extends the cycle time of the sensor.

Monoflop Time: Break between two consecutive bar sequences (Fig. 32). Values between 16...25 μ s can be set for this parameter (default value: 16 μ s).

Error Values: Setting the values which are transmitted in case of a failure.

Power Failure: Setting the time from when a power failure is output.

Error Counter: Setting the number how often in the case of a failure (1...255 times) the old measurement value will be repeated, before the error value will be displayed.

After the settings have been configured, click the "EXIT COMMAND MODE" button. A new menu for exiting the command mode will open. Click the "SAVE AND EXIT" button to exit the command mode and to transfer the changed settings to the sensor. The sensor returns to the normal function and outputs the current position value. The connection icon on the top right will turn to green. The status LED of the sensor flashes green.

NOTICE

Changes to the sensor parameters must also be set to the control system.

Different parameter values on sensor and control systems can lead to unpredictable behavior of the control system.

6. Maintenance and troubleshooting

6.1 Error conditions, troubleshooting

See chapter "5. Commissioning" on page 23.

6.2 Maintenance

The sensor is maintenance-free.

6.3 Repair

Repairs of the sensor may be performed only by MTS Sensors or a repair facility explicitly authorized by MTS Sensors. For return see chapter "2.6 Return" on page 4.

6.4 List of spare parts

No spare parts are available for this sensor.

6.5 Transport and storage

The conditions of transport and storage of the sensor match the operating conditions mentioned in this document.

7. Removal from service/dismantling

The product contains electronic components and must be disposed of in accordance with the local regulations.

8. Technical data

8.1 Technical data Temposonics® RP5

Output							
Interface	SSI (Synchronous Serial Interface) – differential signal in SSI standard (RS-485/RS-422)						
Data format	Binary or gray						
Data length	8...32 bit						
Data transmission rate	70 kBaud ⁵ ...1 MBaud, depending on cable length:						
	Cable length	< 3 m	< 50 m	< 100 m	< 200 m	< 400 m	
	Baud rate	1 MBd	< 400 kBd	< 300 kBd	< 200 kBd	< 100 kBd	
Measured value	Position						
Measurement parameters							
Resolution: Position	0.1...100 µm (0.0001...0.1 mm)						
Resolution: Velocity	0.001 mm/s (determined over 10 measured values)						
Update rate ⁶	Stroke length	25 mm	300 mm	750 mm	1000 mm	2000 mm	6350 mm
	Update rate	10 kHz	3.4 kHz	2.7 kHz	2.1 kHz	1.2 kHz	0.4 kHz
Linearity deviation ⁷	Stroke length	≤ 400 mm	> 400 mm				
	Linearity deviation	≤ ±40 µm	< ±0.01 % F.S.				
	Optional internal linearization: Linearity tolerance (applies for the first magnet for differential measurement)						
	Stroke length	25...300 mm	300...600 mm	600...1200 mm	1200...3000 mm	3000...5000 mm	5000...6350 mm
	typical	± 15 µm	± 20 µm	± 25 µm	± 45 µm	± 85 µm	± 95 µm
	maximum	± 25 µm	± 30 µm	± 50 µm	± 90 µm	± 150 µm	± 190 µm
Repeatability	< ±0.001 % F.S. (minimum ±2.5 µm) typical						
Hysteresis	< 4 µm typical						
Temperature coefficient	< 15 ppm/K typical						
Operating conditions							
Operating temperature	–40...+85 °C (–40...+185 °F)						
Humidity	90 % relative humidity, no condensation						
Ingress protection	IP67 (connectors correctly fitted)/IP68 for cable output						
Shock test	150 g/11 ms, IEC standard 60068-2-27						
Vibration test	30 g/10...2000 Hz, IEC standard 60068-2-6 (excluding resonant frequencies)						
EMC test	Electromagnetic emission according to EN 61000-6-3						
	Electromagnetic immunity according to EN 61000-6-2						
	The sensor meets the requirements of the EC directives and is marked with CE .						
Magnet movement velocity	Magnet slider: Max. 10 m/s; U-magnet: Any; block magnet: Any						
Design/Material							
Sensor electronics housing	Aluminum (painted), zinc die cast						
Sensor profile	Aluminum						
Stroke length	25...6350 mm (1...250 in.)						
Mechanical mounting							
Mounting position	Any						
Mounting instruction	Please consult the technical drawings on page 11						

Technical data “Electrical connection” on page 32

5/ With standard one shot of 16 µs

6/ Sensor with standard settings

7/ With position magnet # 252 182

Temposonics® R-Series V SSI

Operation Manual

Electrical connection	
Connection type	1 × M16 male connector (7 pin) or cable output
Operating voltage	+12...30 VDC ±20 % (9.6...36 VDC)
Power consumption	1.2 W typical
Dielectric strength	500 VDC (DC ground to machine ground)
Polarity protection	Up to -36 VDC
Overvoltage protection	Up to 36 VDC

8.2 Technical data Temposonics® RH5

Output							
Interface	SSI (Synchronous Serial Interface) – differential signal in SSI standard (RS-485/RS-422)						
Data format	Binary or gray						
Data length	8...32 bit						
Data transmission rate	70 kBaud ⁸ ...1 MBaud, depending on cable length:						
	Cable length	< 3 m	< 50 m	< 100 m	< 200 m	< 400 m	
	Baud rate	1 MBd	< 400 kBd	< 300 kBd	< 200 kBd	< 100 kBd	
Measured value	Position						
Measurement parameters							
Resolution: Position	0.1...100 µm (0.0001...0.1 mm)						
Resolution: Velocity	0.001 mm/s (determined over 10 measured values)						
Update rate ⁹	Stroke length	25 mm	300 mm	750 mm	1000 mm	2000 mm	7620 mm
	Update rate	10 kHz	3.4 kHz	2.7 kHz	2.1 kHz	1.2 kHz	0.3 kHz
Linearity deviation ¹⁰	Stroke length	≤ 400 mm	> 400 mm				
	Linearity deviation	≤ ±40 µm	< ±0.01 % F.S.				
	Optional internal linearization: Linearity tolerance (applies for the first magnet for differential measurement)						
	Stroke length	25...300 mm	300...600 mm	600...1200 mm			
	typical	± 15 µm	± 20 µm	± 25 µm			
	maximum	± 25 µm	± 30 µm	± 50 µm			
Repeatability	< ±0.001 % F.S. (minimum ±2.5 µm) typical						
Hysteresis	< 4 µm typical						
Temperature coefficient	< 15 ppm/K typical						
Operating conditions							
Operating temperature	–40...+85 °C (–40...+185 °F)						
Humidity	90 % relative humidity, no condensation						
Ingress protection	IP67 (connectors correctly fitted)/IP68 for cable output						
Shock test	150 g/11 ms, IEC standard 60068-2-27						
Vibration test	30 g/10...2000 Hz, IEC standard 60068-2-6 (excluding resonant frequencies)/ RH5-J: 15 g/10...2000 Hz, IEC standard 60068-2-6 (excluding resonant frequencies)						
EMC test	Electromagnetic emission according to EN 61000-6-3						
	Electromagnetic immunity according to EN 61000-6-2						
	The sensor meets the requirements of the EC directives and is marked with CE .						
Operating pressure	350 bar (5,076 psi)/700 bar (10,153 psi) peak (at 10 × 1 min) for sensor rod/RH5-J: 800 bar (11,603 psi)						
Magnet movement velocity	Any						
Design/Material							
Sensor electronics housing	Aluminum (painted), zinc die cast						
Sensor flange	Stainless steel 1.4305 (AISI 303)						
Sensor rod	Stainless steel 1.4306 (AISI 304L)/RH5-J: Stainless steel 1.4301 (AISI 304)						
Stroke length	25...7620 mm (1...300 in.)/RH5-J: 25...5900 mm (1...232 in.)						
Mechanical mounting							
Mounting position	Any						
Mounting instruction	Please consult the technical drawings on page 12 and page 13						

Technical data “Electrical connection” on page 34

^{8/} With standard one shot of 16 µs

^{9/} Sensor with standard settings

^{10/} With position magnet # 251 416-2

Temposonics® R-Series V SSI

Operation Manual

Electrical connection	
Connection type	1 × M16 male connector (7 pin) or cable output
Operating voltage	+12...30 VDC ±20 % (9.6...36 VDC)
Power consumption	1.2 W typical
Dielectric strength	500 VDC (DC ground to machine ground)
Polarity protection	Up to -36 VDC
Overvoltage protection	Up to 36 VDC

9. Appendix I

Safety declaration

Dear Customer,

If you return one or several sensors for checking or repair, we need you to sign a safety declaration. The purpose of this declaration is to ensure that the returned items do not contain residues of harmful substances and/or that people handling these items will not be in danger.

MTS Sensors order number: _____ Sensor type(s): _____

Serial number(s): _____ Sensor length(s): _____

The sensor has been in contact with the following materials:

Do not specify chemical formulas.
Please include safety data sheets of the substances, if applicable.

In the event of suspected penetration of substances into the sensor, consult MTS Sensors to determine measures to be taken before shipment.

Short description of malfunction:

Corporate information

Company: _____

Address: _____

Contact partner

Name: _____

Phone: _____

E-mail: _____

We hereby certify that the measuring equipment has been cleaned and neutralized.
Equipment handling is safe. Personnel exposure to health risks during transport and repair is excluded.

Stamp

Signature

Date

GERMANY

**MTS Sensor Technologie
GmbH & Co.KG**
Auf dem Schüffel 9
58513 Lüdenscheid, Germany
Tel. +49-23 51-95 87 0
Fax. +49-23 51-5 64 91
info.de@mtssensors.com
www.mtssensors.com

USA

**MTS Systems Corporation
Sensors Division**
3001 Sheldon Drive
Cary, N.C. 27513, USA
Tel. +1 919 677-0100
Fax +1 919 677-0200
info.us@mtssensors.com
www.mtssensors.com

10. Appendix II

CYLINDER PORT DETAILS

PORT DETAIL (PD) FOR RH5-S:

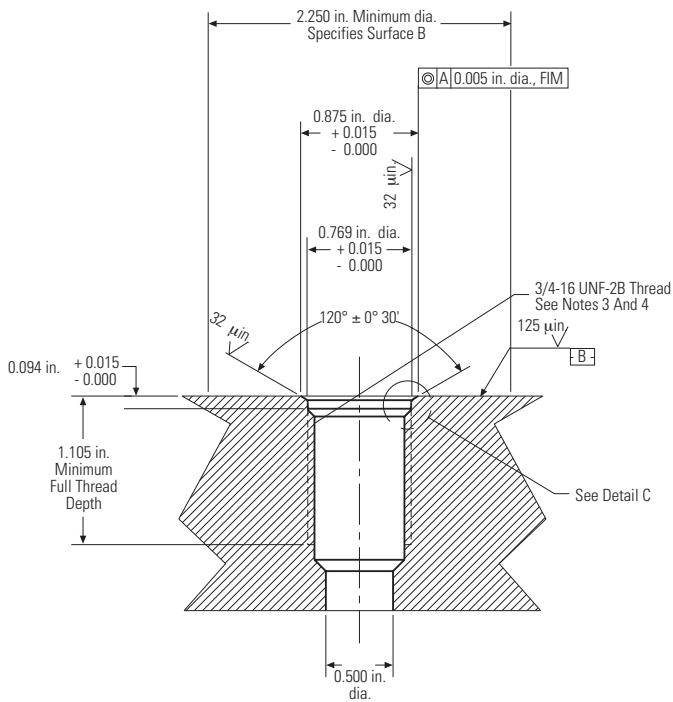

NOTES:

1. Dimensions and tolerances based on ANSI Y14.5-1982.
2. MTS has extracted all pertinent information from MS33649 to generate this document.
3. PD must be square with surface B within 0.005 FIM across 2.250 dia minimum.
4. PD must be concentric with 2.250 dia within 0.030 FIM and with 0.769 dia within 0.005 FIM.
5. Surface texture ANSI B46.1-1978
6. Use O-ring MTS part number 560315 for correct sealing.
7. The thread design shall have sufficient threads to meet strength requirements of material used.
8. Finish counter-bore shall be free from longitudinal and spiral tool marks. Annular tool marks up to 32 microinches maximum will be permissible.

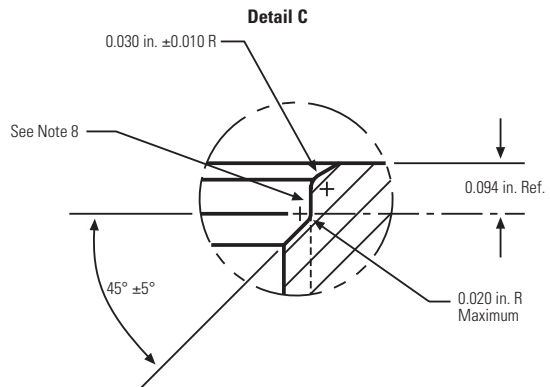

PORT DETAIL (PD) FOR RH5-T:

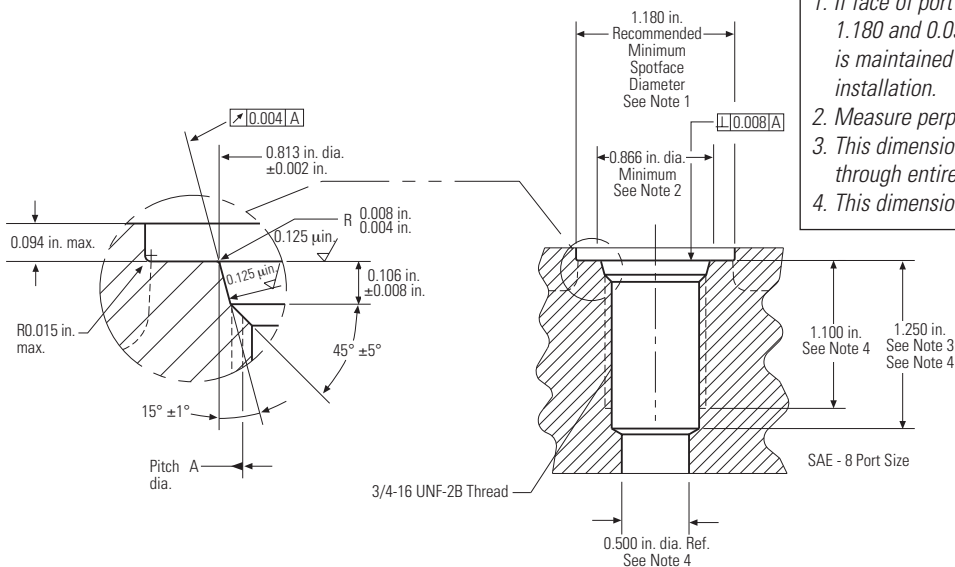

NOTES:

1. If face of port is on a machined surface, dimensions 1.180 and 0.094 need not apply as long as R0.008/0.004 is maintained to avoid damage to the O-ring during installation.
2. Measure perpendicularity to A at this diameter.
3. This dimension applies when tap drill cannot pass through entire boss.
4. This dimension does not conform to SAE J1926/1.

11. Glossary

A

Alarm

The alarm bit is set by the sensor if the sensor detects more magnets (extra magnet) or less magnets (magnet status error) than configured.

Asynchronous mode

In asynchronous mode the position data is continuously updated inside the sensor as quickly as the sensor's measurement cycle will allow, independent of the controller. The controller's loop time will determine when the sensor's most recent data is clocked out over the SSI interface. (→ Synchronous mode)

D

Differential measurement

For differential measurement, the distance between the two position magnets is output as a value.

E

Extrapolation

The native measurement cycle time of a sensor increases with the stroke length. With extrapolation, the sensor is able to report data faster than the native cycle time, independent of the stroke length of the sensor. Without extrapolation, if data is requested faster than the native cycle time, the last measured value is repeated.

F

FIR Filter

The FIR filter (**F**inite **I**mpulse **R**esponse) is used to smooth the measured position value before output. To determine the output value, only input values corresponding to the window (filter window size) are used for filter calculation. The output value is calculated from these input values in the form of a moving average value. (→ IIR Filter)

I

IIR Filter

The IIR filter (**I**nfinite **I**mpulse **R**esponse) is used to smooth the measured position value before output. To determine the output value, the input values corresponding to the filter grade (filter window size) are used for the filter calculation. The previous values are also taken into account when calculating the output value. (→ FIR Filter)

Internal Linearization

The internal linearization offers an improved linearity for an overall higher accuracy of the position measurement. The internal linearization is set for the sensor during production.

M

Measuring direction

When moving the position magnet, the position and velocity values increase in the measuring direction.

- Forward: Values increasing from sensor electronics housing to rod end/profile end
- Reverse: Values decreasing from sensor electronics housing to rod end/profile end

P

Parity

The parity bit is a check bit that is added to a bit string to detect transmission errors. There are even parity and odd parity. With even parity, the parity bit is set so that the total number of 1-bits in the bit string including the parity bit is even. In case of odd parity, the total number of 1-bits in the bit sequence including the parity bit is odd. Even parity is implemented in the R-Series V SSI.

S

Synchronous Serial Interface

SSI (**S**ynchronous **S**erial **I**nterface) is a digital interface where the data is transferred serially. The interface of R-Series V SSI corresponds to SSI industry standard for absolute encoders. Its displacement value is encoded in a 24/25/26 bit binary or gray format and transmitted as a differential signal in SSI standard (RS-485/RS-422).

Synchronous mode

In synchronous mode the measurement and output of the sensor is matched to the data request cycle of the controller. The synchronous mode minimizes the time delay between measurement and output. The synchronous mode is required for sophisticated motion control applications. (→ Asynchronous mode)

• Synchronous mode 1

Using synchronous mode 1, the sensor determines the controller's loop timing and when data is being requested. The sensor then determines when to start the next measurement cycle so that it will complete just in time to deliver the freshest data possible.

• Synchronous mode 2

If new position data is required faster than the sensor's measurement cycle time, synchronous mode 2 provides extrapolated data values, calculated on the fly. A measurement value will be calculated and output to the controller whenever the sensor has not yet completed the next measurement cycle.

• Synchronous mode 3

Synchronous mode 3 provides an additional enhancement to the high speed update feature of synchronous mode 2. For this mode all measurements values which are output are calculated to fully compensate for the inherent lag time due to the sensor's measurement cycle.

T

Temperature in the sensor electronics housing

The temperature in the sensor electronics housing is measured in °C. With this option, the transmitted data word has a length of 32 bits, with the highest 8 bits representing the temperature value, followed by 24 bits for the position value.

USA 3001 Sheldon Drive
MTS Systems Corporation Cary, N.C. 27513
Sensors Division Telefon: +1 919 677-0100
Amerika & APAC Region E-Mail: info.us@mtssensors.com

DEUTSCHLAND Auf dem Schüffel 9
MTS Sensor Technologie 58513 Lüdenscheid
GmbH & Co. KG Telefon: +49 2351 9587-0
EMEA Region & Indien E-Mail: info.de@mtssensors.com

ITALIEN Telefon: +39 030 988 3819
Zweigstelle E-Mail: info.it@mtssensors.com

FRANKREICH Telefon: +33 1 58 4390-28
Zweigstelle E-Mail: info.fr@mtssensors.com

UK Telefon: +44 79 44 15 03 00
Zweigstelle E-Mail: info.uk@mtssensors.com

SKANDINAVIEN Telefon: +46 70 29 91 281
Zweigstelle E-Mail: info.sca@mtssensors.com

CHINA Telefon: +86 21 2415 1000 / 2415 1001
Zweigstelle E-Mail: info.cn@mtssensors.com

JAPAN Telefon: +81 3 6416 1063
Zweigstelle E-Mail: info.jp@mtssensors.com

Document Part Number:
552011 Revision B (EN) 12/2020



www.mtssensors.com