

Temposonics®

Magnetostrictive Linear Position Sensors



Sensor with Ex approval

**TH SSI ATEX / IECEx / CEC / NEC / KCs / EAC Ex certified /
Japanese approval**
Operation Manual

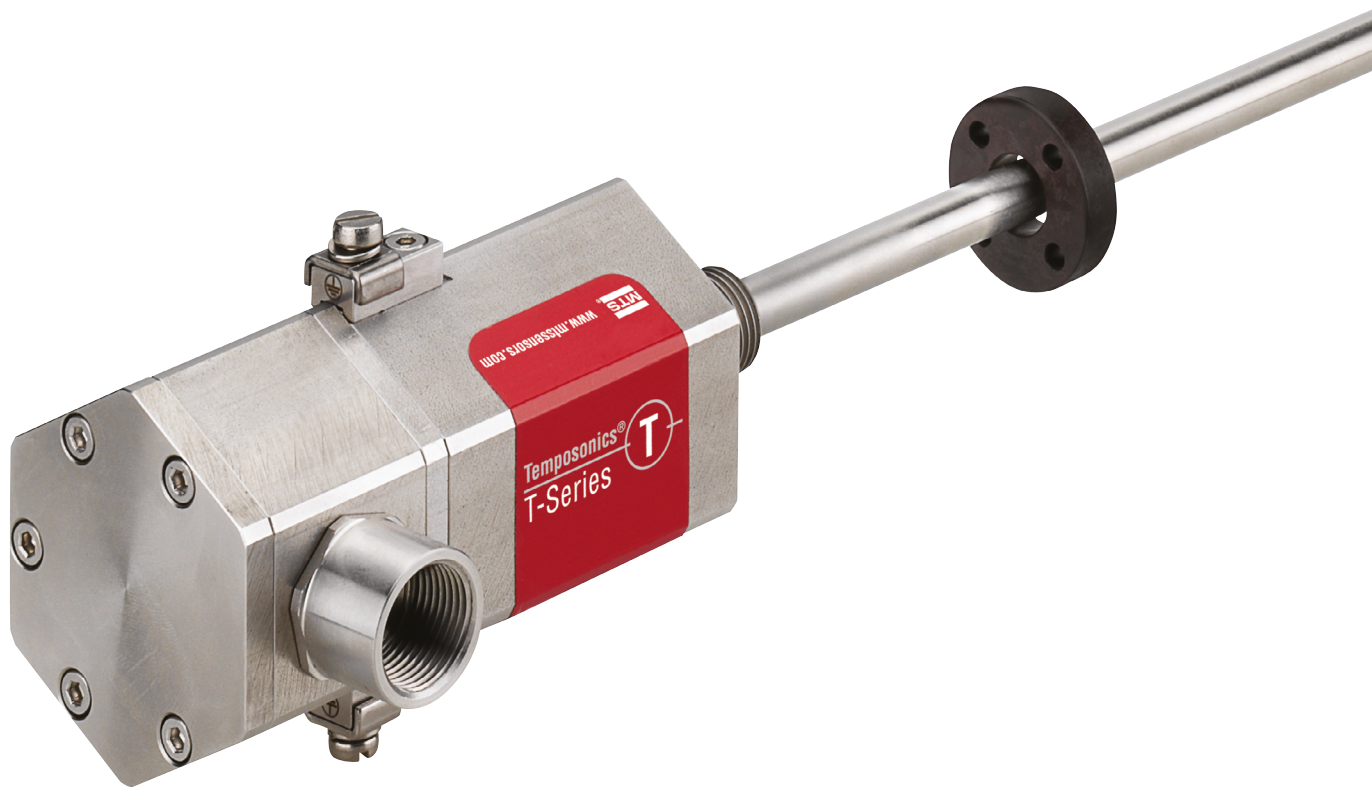


Table of contents

1. Introduction	3
1.1 Purpose and use of this manual	3
1.2 Used symbols and warnings	3
2. Safety instructions	3
2.1 Intended use	3
2.2 Foreseeable misuse	4
2.3 Installation, commissioning and operation	4
2.4 Safety instructions for use in explosion-hazardous areas	5
2.5 Warranty	6
2.6 Return	6
3. Identification	7
3.1 Order code of Temposonics® TH	7
3.2 Nameplate	9
3.3 Approvals	9
3.4 Scope of delivery	9
4. Product description and commissioning	10
4.1 Functionality and system design	10
4.2 Styles and installation of Temposonics® TH	11
4.3 Magnet installation	17
4.4 Electrical connection	19
4.5 Frequently ordered accessories	24
5. Operation	27
5.1 Getting started	27
5.2 Programming and configuration	27
6. Maintenance and troubleshooting	32
6.1 Error conditions, troubleshooting	32
6.2 Maintenance	32
6.3 Repair	32
6.4 List of spare parts	32
6.5 Transport and storage	32
7. Removal from service / dismantling	32
8. Technical data Temposonics® TH	33
9. Declaration of conformity	35
10. Appendix	37

1. Introduction

1.1 Purpose and use of this manual

Before starting the operation of Temposonics® position sensors, read this documentation thoroughly and follow the safety information. Keep the manual for future reference!

The content of this technical documentation and of its appendix is intended to provide information on mounting, installation and commissioning by qualified automation personnel ¹ or instructed service technicians who are familiar with the project planning and dealing with Temposonics® sensors.

1.2 Used symbols and warnings

Warnings are intended for your personal safety and for avoidance of damage to the described product or connected devices. In this documentation, safety information and warnings to avoid dangers that might affect the life and health of operating or service personnel or cause material damage are highlighted by the pictogram defined below.

Symbol	Meaning
NOTICE	This symbol is used to point to situations that may lead to material damage, but not to personal injury.

2. Safety instructions

2.1 Intended use

This product must be used only for the applications defined under item 1 to item 4 and only in conjunction with the third-party devices and components recommended or approved by MTS Sensors. As a prerequisite of proper and safe operation, the product requires correct transport, storage, mounting and commissioning and must be operated with utmost care.

1. The sensor systems of all Temposonics® series are intended exclusively for measurement tasks encountered in industrial, commercial and laboratory applications. The sensors are considered as system accessories and must be connected to suitable evaluation electronics, e.g. a PLC, IPC, indicator or other electronic control unit.
2. The sensor's surface temperature class is T4.
3. The EU-Type Examination Certificates and Certificates of Compliance have to be taken into account including any special condition defined therein.

^{1/} The term "qualified technical personnel" characterizes persons who:

- are familiar with the safety concepts of automation technology applicable to the particular project
- are competent in the field of electromagnetic compatibility (EMC)

4. The position sensor may be used in zones (ATEX, IECEx) and Classes, Zones and Divisions (CEC, NEC) according to chapter 8. Any use of this product outside of these approved areas will void the warranty and all manufacturer's product responsibilities and liabilities. For non-hazardous areas MTS Sensors recommends to use the version N (not approved).

Zone concept			
Ex-Atmosphere	Zone	Category	Explosion group
Gas-Ex	In the baffle between Zone 0		Up to IIC (at the rod)
Gas-Ex	Zone 1	2G	IIA, IIB, IIC
Gas-Ex	Zone 2	3G	IIA, IIB, IIC
Dust-Ex	Zone 21	2D	IIIA, IIIB, IIIC
Dust-Ex	Zone 22	3D	IIIA, IIIB, IIIC
Gas-Ex	In the baffle between Zone 0 and		Up to IIC (at the rod)
	Zone 1 or Zone 2		
Gas-Ex	In the baffle between Zone 0 and		Up to IIC (at the rod)
	Zone 21 or Zone 22		
Dust-Ex	Zone 21 or Zone 22		Up to IIIC (at the connection chamber)

Class and Division concept			
Ex-Atmosphere	Class	Division	Group
Gas-Ex	Class I	Div. 1	A*, B, C, D
Gas-Ex	Class I	Div. 2	A, B, C, D
Dust-Ex	Class II/III	Div. 1	E, F, G
Dust-Ex	Class II/III	Div. 2	E, F, G

*Cl. I Div. 1 Gr. A not valid for Canada

- have received adequate training for commissioning and service operations
- are familiar with the operation of the device and know the information required for correct operation provided in the product documentation

2.2 Forseeable misuse

Forseeable misuse	Consequence
Lead compensating currents through the enclosure	The sensor will be damaged
Use sensor without external fuse in Zone 0	In case of failure, the sensor might overheat
Use a fuse with more than 125 mA	In case of failure, the sensor might overheat
Wrong sensor connection	The sensor will not work properly or will be destroyed
Operate the sensor out of the operating temperature range	No signal output – The sensor can be damaged
Power supply is out of the defined range	Signal output is wrong / no signal output / the sensor will be damaged
Position measurement is influenced by an external magnetic field	Signal output is wrong
Cables are damaged	Short circuit – the sensor can be destroyed / sensor does not respond
Spacers are missing / are installed in a wrong order	Error in position measurement
Wrong connection of ground / shield	Signal output is disturbed – The electronics can be damaged
Use of a magnet that is not certified by MTS Sensors	Error in position measurement

2.3 Installation, commissioning and operation

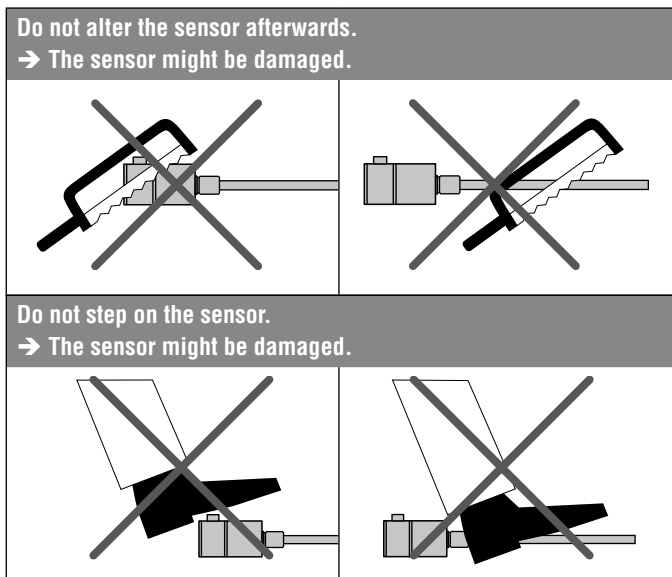
The position sensors must be used only in technically safe condition. To maintain this condition and to ensure safe operation, installation, connection, cable installation and service, work may be performed only by qualified technical personnel, according to IEC 60079-14, TRBS 1203, Canadian Electrical Code (CEC) and National Electrical Code (NEC) and local regulations.

If danger of injury to persons or of damage to operating equipment is caused by sensor failure or malfunction, additional safety measures such as plausibility checks, limit switches, EMERGENCY STOP systems, protective devices etc. are required. In the event of trouble, shut down the sensor and protect it against accidental operation.

Safety instructions for commissioning

To maintain the sensor's operability, it is mandatory to follow the instructions given below.

1. Follow the specifications given in the technical data.
2. Ensure that equipment and associated components used in a hazardous environment are selected and installed in compliance with regulations governing the geographical location and facility. Only install equipment that complies with the types of protection relevant to the applicable Classes, Zones, Divisions and Groups.
3. In explosive atmospheres use only such auxiliary components that meet all requirements of the local and national standards.
4. The potential equalisation of the system has to be established according to the regulations of erection applicable in the respective country of use (VDE 0100 part 540; IEC 364-5-54).
5. Sensors from MTS Sensors are approved only for the intended use in industrial environments (see chapter "2.1 Intended use" on page 3). Contact the manufacturer for advice if aggressive substances are present in the sensor environment.
6. Measures for lightning protection have to be taken by the user.
7. The user is responsible for the mechanical protection of the sensor.
8. The sensor may be used only for fixed installations with permanently wired cables. The user shall ensure that cables and cable glands correspond to the risk assessment of the hazardous application as well as to thermic, chemical and mechanical environmental conditions. The user is also responsible for the required strain relief. When selecting the sealing, the maximum thermal load of the cables must be taken into account.
9. The user is responsible for meeting all safety conditions as outlined by:
 - Installation instructions
 - Local prevailing standards and regulations
10. Any parts of the equipment which got stuck (e.g. by frost or corrosion) may not be removed by force if potentially explosive atmosphere is present.
11. The surface temperatures of equipment parts must be kept clearly below the ignition temperature of the foreseeable air/dust mixtures in order to prevent the ignition of suspended dust.



How to ensure safe commissioning

1. Protect the sensor against mechanical damage during installation and operation.
2. Do not use damaged products and secure them against unintentional commissioning. Mark damaged products as being defective.
3. Prevent electrostatic charges.
4. Do not use the sensor in cathodic systems for corrosion protection. Do not allow parasitic currents on the sensor housing.
5. Switch off the supply voltage prior to disconnecting or connecting the connectors.
6. Connect the sensor very carefully and pay attention to the polarity of connections, power supply as well as to the shape and duration of control pulses.
7. Cable entry temperature and branching point temperature may reach 104 °C (219 °F) and 116 °C (241 °F) respectively. Select suitable cable and entry device.
8. For field wiring, use cables suitable for the service temperature range of -40 °C (-40 °F) to +116 °C (241 °F).
9. Do not open when energized. Open the sensor only as shown in Fig. 6 on page 13.
10. A seal shall be installed within 18" of the enclosure (for NEC / CEC only).
11. Use only approved power supplies of Category II according to IEC 61010-1.
12. Ensure that the specified permissible limit values of the sensor for operating voltage, environmental conditions, etc. are met.
13. Make sure that:
 - the sensor and associated components were installed according to the instructions
 - the sensor enclosure is clean
 - all screws (only those of quality 6.8, A2-50 or A4-50 are allowed) are tightened according to specified fastening torque in Fig. 6
 - the cable glands certified according to the required hazardous area classification and IP protection are tightened according to the manufacture's specifications
 - surfaces limiting the joint shall not be machined or painted subsequently (flameproof enclosure)
 - surfaces limiting the joint have not been provided with a seal (flameproof enclosure)
 - the magnet does not grind on the rod. This could cause damage to the magnet and the sensor rod. If there is contact between the moving magnet (including the magnet holder) and the sensor rod, make sure that the maximum speed of the moving magnet is less or equal 1 m/s.
14. Ground the sensor via one of the two ground lugs. Both the sensor and the moving magnet including magnet holder must be connected to protective ground (PE) to avoid electrostatic discharge (ESD).
15. Before applying power, ensure that nobody's safety is jeopardized by starting machines.
16. Check the function of the sensor regularly and provide documentation of the checks (see chapter "6.2 Maintenance" on page 32).

2.4 Safety instructions for use in explosion-hazardous areas

The sensor has been designed for operation inside explosion-hazardous areas. It has been tested and left the factory in a condition in which it is safe to operate. Relevant regulations and standards have been observed. According to the marking (ATEX, IECEx, CEC, NEC, KCs, EAC Ex, Japanese approval) the sensor is approved only for operation in defined hazardous areas (see chapter "2.1 Intended use" on page 3).

When do you need an external fuse?

Zone / Div.	T-Series sensor
Zone 0 (rod only)	External fuse required
Zone 1 / 21	No additional fuse
Zone 2 / 22	No additional fuse
Div. 1	External fuse recommended

How to install a T-Series sensor in Zone 0 according to the guidelines (ATEX, IECEx, CEC, NEC, KCs, EAC Ex, Japanese approval)

1. Install an external fuse in compliance with IEC 127 outside the Ex-atmosphere. Connect it upstream to the equipment.
Current: 125 mA
2. Install the sensor housing in Zone 1, Zone 2, Zone 21 or Zone 22. Only the rod section (for version D, G, and E) can extend into Zone 0.
3. Follow the safety regulations detailed in IEC/EN 60079-26, ANSI/ISA 60079-26 (12.00.03), ANSI/ISA/IEC/EN 60079-10-1 and JNIOOSH-TR-46-2 to ensure isolation between Zone 0 and Zone 1.
4. When installing the TH sensor in the boundary wall for Zone 0, the corresponding requirements in ANSI/ISA/IEC/EN 60079-26 and ANSI/ISA/IEC/EN 60079-10-1 have to be noticed. Thereby the screw-in thread is to be sealed air tightly (IP67) according to ANSI/ISA/IEC/EN 60079-26 and ANSI/ISA/IEC/EN 60079-10-1.

2.5 Warranty

MTS Sensors grants a warranty period for the Temposonics® position sensors and supplied accessories relating to material defects and faults that occur despite correct use in accordance with the intended application ². The MTS Sensors obligation is limited to repair or replacement of any defective part of the unit. No warranty can be provided for defects that are due to improper use or above average stress of the product, as well as for wear parts. Under no circumstances will MTS Sensors accept liability in the event of offense against the warranty rules, no matter if these have been assured or expected, even in case of fault or negligence of the company. MTS Sensors explicitly excludes any further warranties. Neither the company's representatives, agents, dealers nor employees are authorized to increase or change the scope of warranty.

2.6 Return

For diagnostic purposes, the sensor can be returned to MTS Sensors. Any shipment cost is the responsibility of the sender ². For a corresponding form, see chapter "10. Appendix" on page 37.

^{2/} See also applicable MTS Sensors terms of sales and delivery on:
www.mtssensors.com

3. Identification

3.1 Order code of Temposonics® TH

1	2	3	4	5	6	7	8	9	10	11	12	13	14	15	16	17	18	19	20	21	22	23	24	25	
T	H												N	N	S										
a		b	c					d			e	f	g	h	i										

Optional

a Sensor model

T	H	Rod
---	---	-----

b Design

Enclosure Type 3:
TH rod sensor with housing material stainless steel 1.4305 (AISI 303) and rod material stainless steel 1.4306 (AISI 304L)

M	Threaded flange with flat-face (M18×1.5-6g)
N	Threaded flange with raised-face (M18×1.5-6g)
S	Threaded flange with flat-face (¾"-16 UNF-3A)
T	Threaded flange with raised-face (¾"-16 UNF-3A)

Enclosure Type 3X:
TH rod sensor with housing material stainless steel 1.4404 (AISI 316L) and rod material stainless steel 1.4404 (AISI 316L)

F	Threaded flange with flat-face (¾"-16 UNF-3A)
G	Threaded flange with raised-face (¾"-16 UNF-3A)
W	Threaded flange with flat-face (M18×1.5-6g)

c Stroke length

X	X	X	X	M	0025...7620 mm
---	---	---	---	---	----------------

Standard stroke length (mm)	Ordering steps
25 ... 500 mm	5 mm
500 ... 750 mm	10 mm
750...1000 mm	25 mm
1000...2500 mm	50 mm
2500...5000 mm	100 mm
5000...7620 mm	250 mm

X	X	X	X	U	001.0...300.0 in.
---	---	---	---	---	-------------------

Standard stroke length (in.)	Ordering steps
1 ... 20 in.	0.2 in.
20 ... 30 in.	0.4 in.
30 ... 40 in.	1.0 in.
40...100 in.	2.0 in.
100...200 in.	4.0 in.
200...300 in.	10.0 in.

Non standard stroke lengths are available; must be encoded in 5 mm / 0.1 in. increments

d Connection type

C	0	1	Side connection with thread ½"-14 NPT (All versions)
C	1	0	Top connection with thread ½"-14 NPT (All versions)
M	0	1	Side connection with thread M16×1.5-6H (Version E & N)
M	1	0	Top connection with thread M16×1.5-6H (Version E & N)
N	0	1	Side connection with thread M20×1.5-6H (All versions)
N	1	0	Top connection with thread M20×1.5-6H (All versions)

e Operating voltage

1	+24 VDC (-15 / +20 %)
A	+24 VDC (-15 / +20 %) includes shock improved option (stroke length 25...3760 mm (1...148 in.))

f Version (see chapter 8 for further information)

D	Ex db and Ex tb (A/F 55)
E	Ex db eb and Ex tb (A/F 55)
G	Ex db and Ex tb (A/F 60) US & CA approval: Explosionproof (XP) (Note: Group A is not available for Canada)
N	Not approved

g Functional safety type

N	Not approved
---	--------------

h Additional option type

N	None
---	------

i See next page

i	Output
S (17) (18) (19) (20) (21) (22) (23) (24) (25) = Synchronous Serial Interface	
Data length (box no. 17)	
1	25 bit
2	24 bit
3	26 bit
Output format (box no. 18)	
B	Binary
G	Gray
Resolution (box no. 19)	
1	0.005 mm
2	0.01 mm
3	0.05 mm
4	0.1 mm
5	0.02 mm
6	0.002 mm
8	0.001 mm
9	0.0005 mm
Filtering performance (box no. 20)	
1	Standard (no filters)
8	Noise reduction filter (8 measurements)
A	No filter + error delay (4 cycles)
C	No filter + error delay (8 cycles)
D	No filter + error delay (10 cycles)
G	Noise reduction filter (8 measurements) + error delay (10 cycles)
K	Peak reduction filter (8 measurements)
N	Peak reduction filter (8 measurements) + error delay (10 cycles)
Signal options (box no. 21, 22)	
0	0 Measuring direction forward, asynchronous mode
0	1 Measuring direction reverse, asynchronous mode
0	2 Measuring direction forward, synchronous mode 1
9	9 Write "9" in box no. 21 and 22 for using further combinations in boxes 23, 24, 25

i	Output (continued)
Measurement contents (optional: Box no. 23) Note: Choose "9" in box no. 21 and 22	
1	Position measurement
2	Differentiation measurement ³
3	Velocity measurement
4	Position measurement + temperature measurement (only with data length = 24 bit)
5	Differentiation measurement ³ + temperature measurement (only with data length = 24 bit)
6	Velocity measurement + temperature measurement (only with data length = 24 bit)
Direction and sync. mode (optional: Box no. 24) Note: Choose "9" in box no. 21 and 22	
1	Measuring direction forward, asynchronous mode
2	Measuring direction forward, synchronous mode 1
3	Measuring direction forward, synchronous mode 2
4	Measuring direction forward, synchronous mode 3
5	Measuring direction reverse, asynchronous mode
6	Measuring direction reverse, synchronous mode 1
7	Measuring direction reverse, synchronous mode 2
8	Measuring direction reverse, synchronous mode 3
Diagnostics (optional: Box no. 25) Note: Choose "9" in box no. 21 and 22	
0	No further options
2	Additional alarm bit + parity even bit (not available for temperature output, only with data length = 24 bit)

NOTICE

Use magnets of the same type (e.g. 2 ring magnets with part no. 201 542-2) for differentiation measurement.

3/ You need a second magnet for differentiation measurement

3.2 Nameplate

<p>THT0420UC101DNNS1B1C02 In: 24 VDC Typ. 100 mA YofC: 21/2017 Out: 0.005 mm / 25 Bit binary Enclosure type 3 S/N: 17210255</p>  <p>CML 16 ATEX 1090X CE 2503 IECEX CML 16.0039X Ⓜ II 1/2G Ex db IIC T4 Ga/Gb Ⓜ II 1G/2D Ex tb IIIC T 130 °C Ga/Db</p> <p>–40 °C ≤ Ta ≤ 75 °C IP66 / IP67</p> <p>Датчик серии Т ОС ВО ЗАО ТИБР №ТС RU C-DE.ГБ08.В.01976 Ga/Gb Ex db IIC T4 X Da/Db Ex tb IIIC T130 °C X</p>  <p>Variant with flameproof connection chamber Version D</p>	<p>THT0420UC101GNNS1B1C02 In: 24 VDC Typ. 100 mA YofC: 21/2017 Out: 0.005 mm / 25 Bit binary Enclosure type 3 S/N: 17210255</p>  <p>CML 16 ATEX 1090X CE 2503 IECEX CML 16.0039X Ⓜ II 1/2G Ex db IIC T4 Ga/Gb Ⓜ II 1G/2D Ex tb IIIC T 130 °C Ga/Db</p> <p>Class I Div 1 Groups A, B, C, D T4 Class II/III Div 1 Groups E, F, G T130 °C Class I Zone 0/1 AEx d / Ex d IIC T4 Class II/III Zone 21 AEx tb / Ex tb IIIC T130°C Group A is not approved for Canada</p> <p>–40 °C ≤ Ta ≤ 75 °C IP66 / IP67</p> <p>Датчик серии Т ОС ВО ЗАО ТИБР №ТС RU C-DE.ГБ08.В.01976 Ga/Gb Ex db IIC T4 X Da/Db Ex tb IIIC T130 °C X</p>  <p>Variant with flameproof / explosionproof connection chamber Version G</p>	<p>THT0420UC101ENNS1B1C02 In: 24 VDC Typ. 100 mA YofC: 21/2017 Out: 0.005 mm / 25 Bit binary Enclosure type 3 S/N: 17210255</p>  <p>CML 16 ATEX 1090X CE 2503 IECEX CML 16.0039X Ⓜ II 1/2G Ex db eb IIC T4 Ga/Gb Ⓜ II 1G/2D Ex tb IIIC T130 °C Ga/Db</p> <p>–40 °C ≤ Ta ≤ 75 °C IP66 / IP67</p> <p>Датчик серии Т ОС ВО ЗАО ТИБР №ТС RU C-DE.ГБ08.В.01976 Ga/Gb Ex db eb IIC T4 X Da/Db Ex tb IIIC T130 °C X</p>  <p>Variant with increased safety connection chamber Version E</p>
--	---	--

Fig. 1: Example of a nameplate of a TH sensor

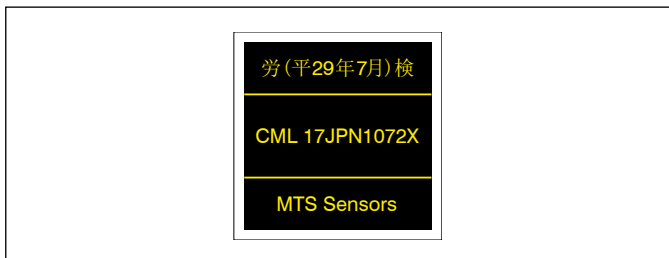


Fig. 2: Label for Japanese approval

3.3 Approvals

See chapter “8. Technical data Temposonics® TH” on page 33 f..

NOTICE

For a detailed overview of the certifications, see www.mtssensors.com

3.4 Scope of delivery

TH (rod sensor):

- Sensor

4. Product description and commissioning

4.1 Functionality and system design

Product designation

- Position sensor Temposonics® T-Series

Sensor model

- Temposonics® TH (rod sensor)

Stroke length

- 25...7620 mm (1...300 in.)
- 25...3760 mm (1...148 in.) for shock improved option

Output signal

- SSI

Application

Temposonics® position sensors are used for measurement and conversion of the length (position) variable in the fields of automated systems and mechanical engineering.

The T-Series sensors are designed for installation in a raised or flat-face flanged hydraulic cylinder, for use as an open-air position sensor or as a liquid level sensor with the addition of a float.

Principle of operation and system construction

The absolute, linear position sensors provided by MTS Sensors rely on the company's proprietary Temposonics® magnetostrictive technology, which can determine position with a high level of precision and robustness. Each Temposonics® position sensor consists of a ferromagnetic waveguide, a position magnet, a strain pulse converter and supporting electronics. The magnet, connected to the object in motion in the application, generates a magnetic field at its location on the waveguide. A short current pulse is applied to the waveguide. This creates a momentary radial magnetic field and torsional strain on the waveguide. The momentary interaction of the magnetic fields releases a torsional strain pulse that propagates the length of the waveguide. When the ultrasonic wave reaches the end of the waveguide it is converted into an electrical signal. Since the speed of the ultrasonic wave in the waveguide is precisely known, the time required to receive the return signal can be converted into a linear position measurement with both high accuracy and repeatability.

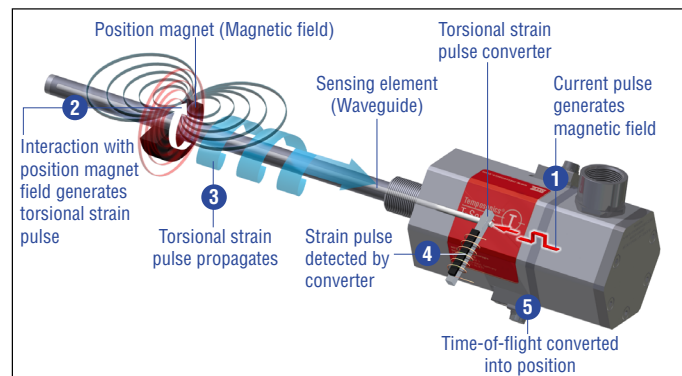


Fig. 3: Time-of-flight based magnetostrictive position sensing principle

T-Series models

The T-Series is available in four variations, three of which are hazardous classifications:

- Flameproof housing with flameproof connection chamber (version D)
- Flameproof (explosionproof) housing with flameproof (explosionproof) connection chamber (version G)
- Flameproof housing with increased safety connection chamber (version E)
- Non-hazardous (version N)

The sensor assembly is offered in 1.4305 (AISI 303) stainless steel and in 1.4404 (AISI 316L). Associated with hazardous rating the sensor meets IP66 / IP67. For non-hazardous environments the sensor meets IP66, IP67, IP68, IP69K and NEMA 4X.

4.2 Styles and installation of Temposonics® TH

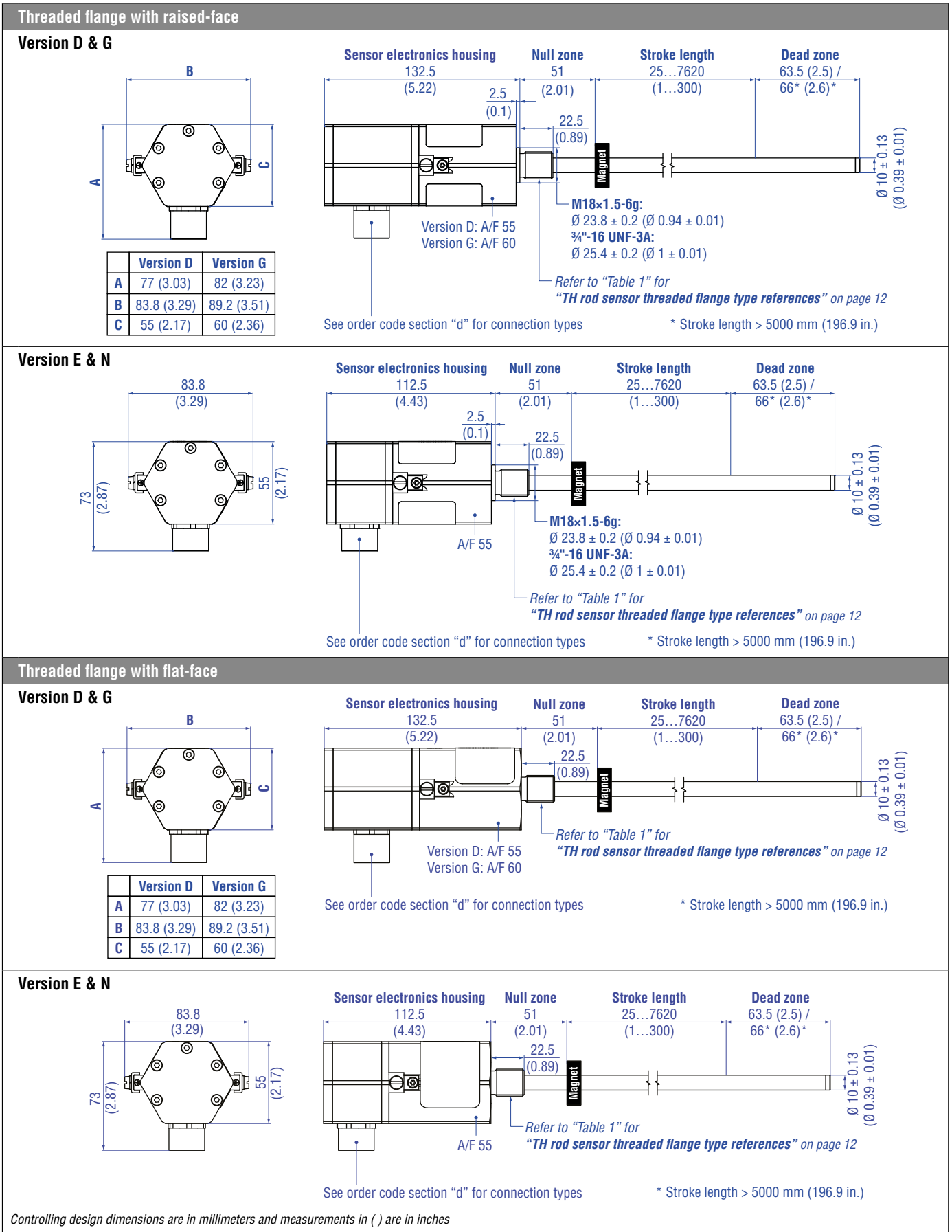


Fig. 4: Temposonics® TH with ring magnet

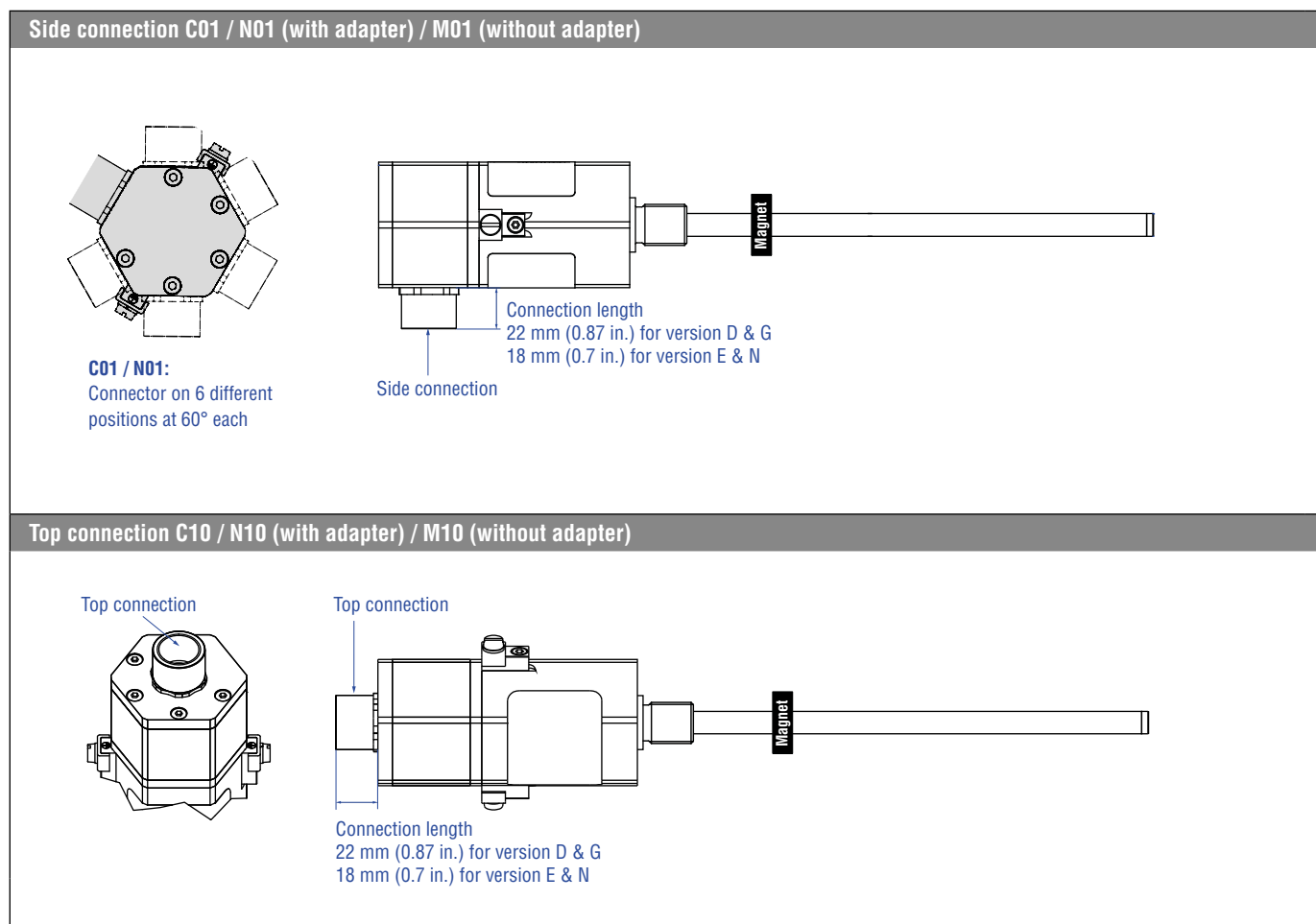


Fig. 5: Temposonics® TH connection options

Threaded flange type	Description	Threaded flange
F	Threaded flange with flat-face Stainless steel 1.4404 (AISI 316L)	¾"-16 UNF-3A
G	Threaded flange with raised-face Stainless steel 1.4404 (AISI 316L)	¾"-16 UNF-3A
M	Threaded flange with flat-face Stainless steel 1.4305 (AISI 303)	M18×1.5-6g
N	Threaded flange with raised-face Stainless steel 1.4305 (AISI 303)	M18×1.5-6g
S	Threaded flange with flat-face Stainless steel 1.4305 (AISI 303)	¾"-16 UNF-3A
T	Threaded flange with raised-face Stainless steel 1.4305 (AISI 303)	¾"-16 UNF-3A
W	Threaded flange with flat-face Stainless steel 1.4404 (AISI 316L)	M18×1.5-6g

Table 1: TH rod sensor threaded flange type references

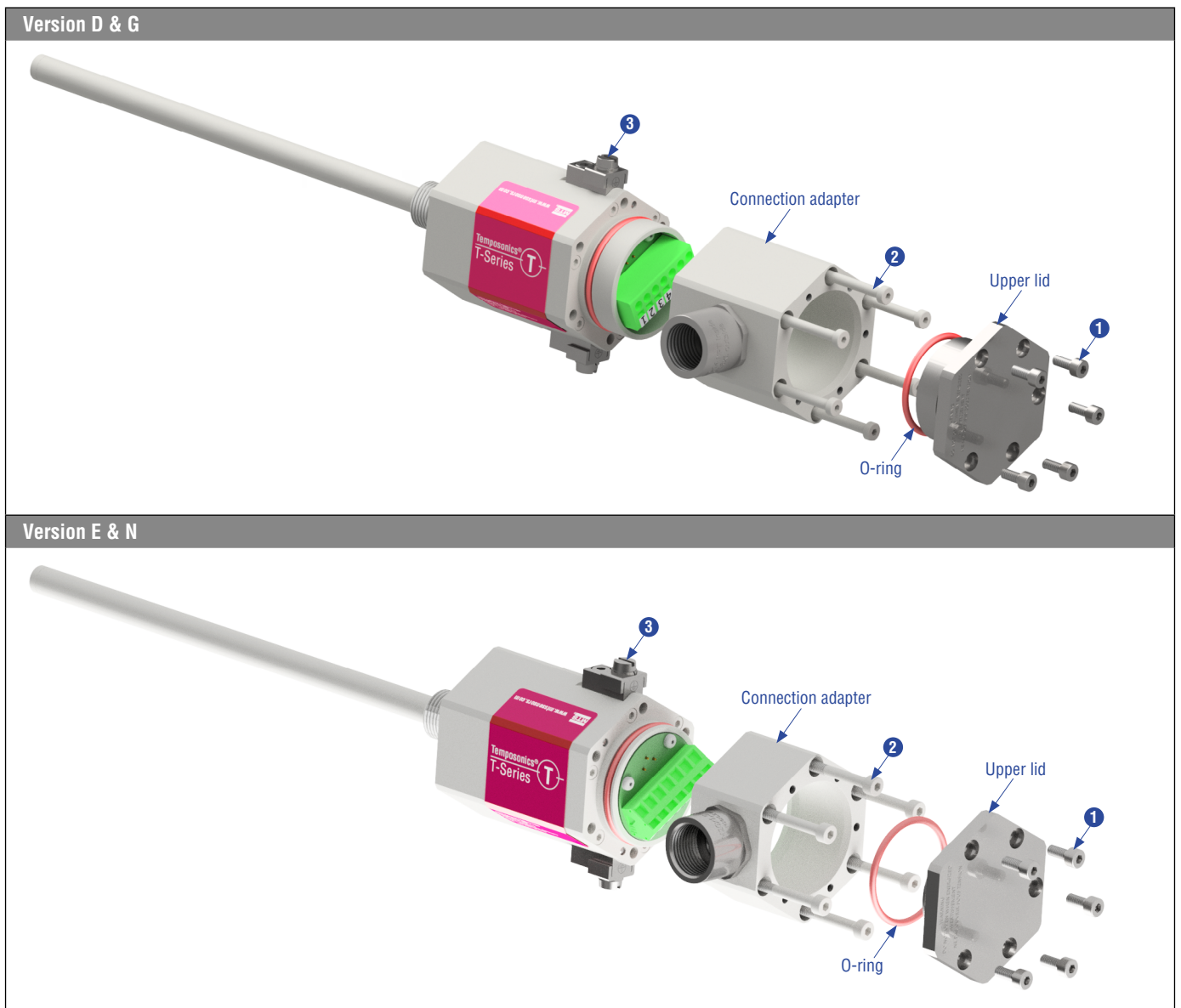


Fig. 6: Temposonics® TH exploded view drawing

Part	Fastening torque
1 Screw M4×10	1.2 Nm
2 Screw M4×40	1.2 Nm
3 Earthing connection: M5×8 for mounting	2.5 Nm

NOTICE

Connect cable to sensor

See page 21 ff. for more details.

Change orientation of cable bushing (C01, M01, N01)

Loosen the five hexagonal screws M4 (A/F 3) and remove the upper lid (Fig. 6). Then loosen the six hexagonal screws M4 (A/F 3) of the connection adapter (Fig. 6). Change the orientation of the connector on six different positions at 60° each. Note the example on page 21 ff..

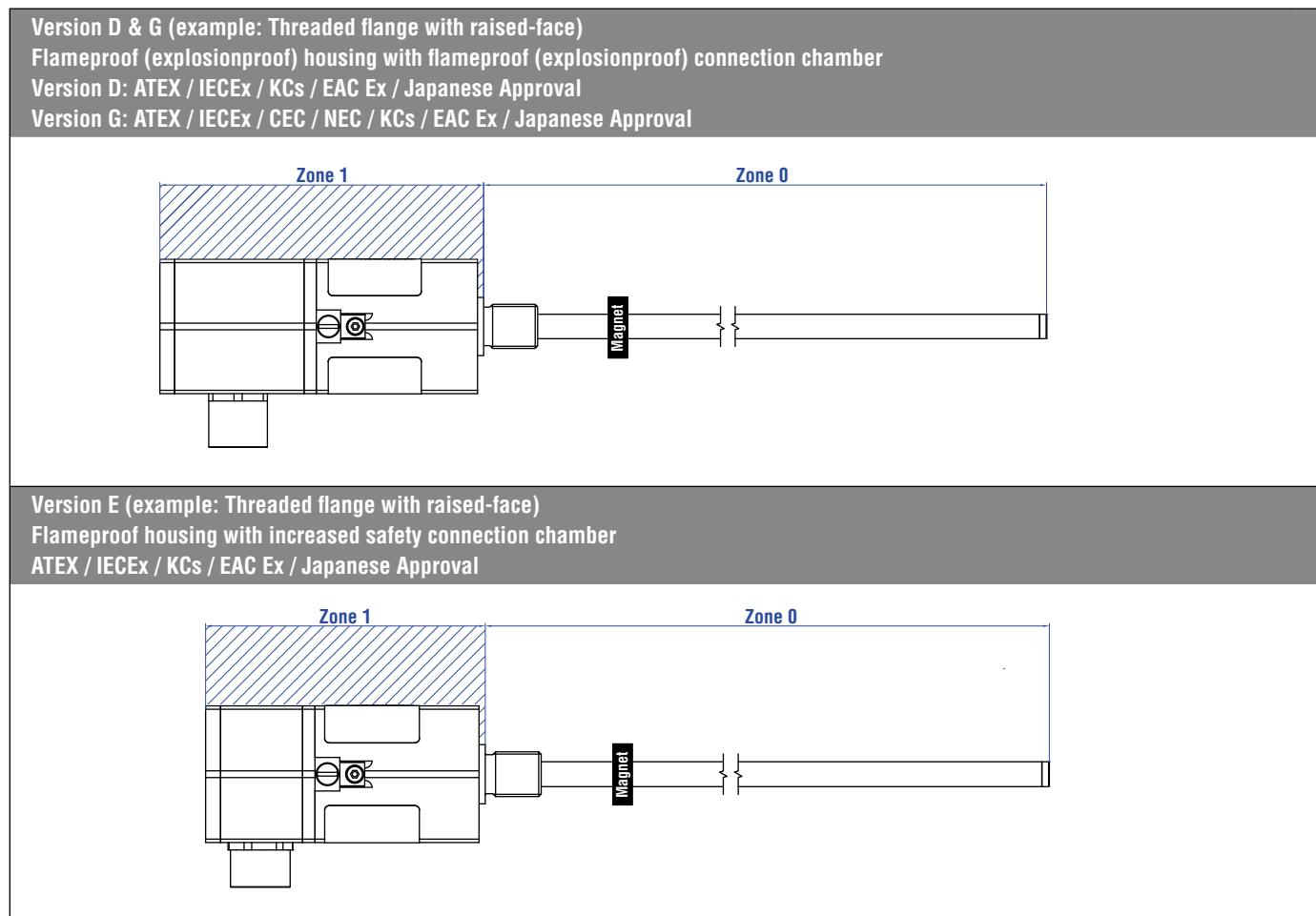


Fig. 7: Temposonics® TH Zone classification

NOTICE

Seal sensor according to ingress protection IP67 between Zone 0 and Zone 1.

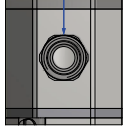
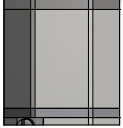

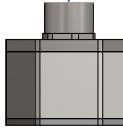
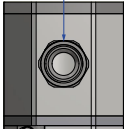
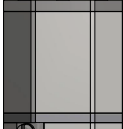
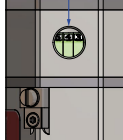

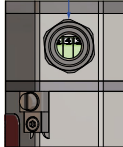
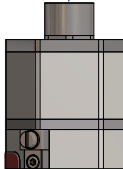
Connection options for version D & G		Connection options for version E & N	
C01	C10	C01	C10
 <p>Side connection with thread ½"-14 NPT</p>	 <p>Top connection with thread ½"-14 NPT</p>	 <p>Side connection with thread ½"-14 NPT</p>	 <p>Top connection with thread ½"-14 NPT</p>
N01	N10	M01	M10
 <p>Side connection with thread M20×1.5-6H</p>	 <p>Top connection with thread M20×1.5-6H</p>	 <p>Side connection with thread M16×1.5-6H</p>	 <p>Top connection with thread M16×1.5-6H</p>
		N01	N10
		 <p>Side connection with thread M20×1.5-6H</p>	 <p>Top connection with thread M20×1.5-6H</p>

Fig. 8: Connection options

Installation of TH with threaded flange

Fix the sensor rod via threaded flange M18x1.5-6g or ¾"-16 UNF-3A.

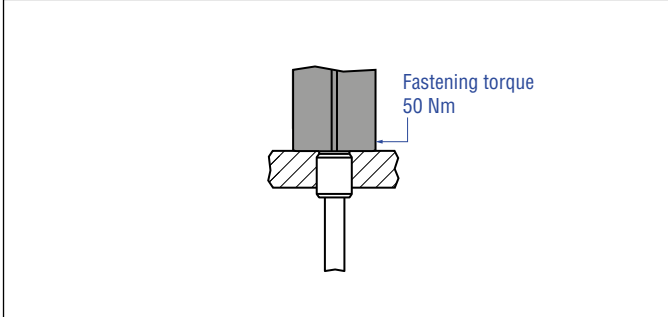


Fig. 9: Mounting example of threaded flange

In the case of threaded flange M18x1.5-6g provide a screw hole based on ISO 6149-1 (Fig. 13). See ISO 6149-1 for further information.

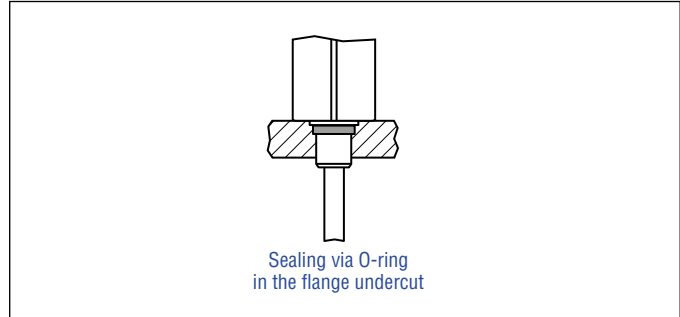


Fig. 11: Possibility of sealing for threaded flange with raised-face

Installation of a rod-style sensor in a fluid cylinder

The rod-style version has been developed for direct stroke measurement in a fluid cylinder. Mount the sensor via threaded flange or a hex nut.

- Mounted on the face of the piston, the position magnet travels over the rod without touching it and indicates the exact position through the rod wall – independent of the hydraulic fluid.
- The pressure resistant sensor rod is installed into a bore in the piston rod.

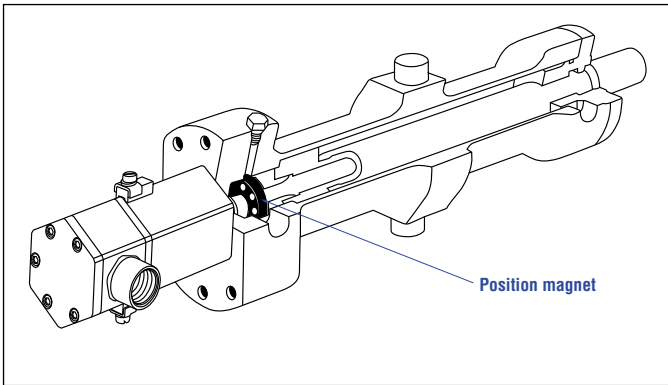


Fig. 10: Sensor in cylinder

Hydraulics sealing for threaded flange with flat-face

There are two ways to seal the flange contact surface (Fig. 12):

1. A sealing by using an O-ring (e.g. 22.4 x 2.65 mm (0.88 x 0.1 in.), 25.07 x 2.62 mm (0.99 x 0.1 in.)) in a cylinder end cap groove.
2. A sealing by using an O-ring in the undercut.
 For threaded flange (¾"-16 UNF-3A) »F« / »S«:
 O-ring 16.4 x 2.2 mm (0.65 x 0.09 in.) (part no. 560 315)
 For threaded flange (M18x1.5-6g) »M« / »W«:
 O-ring 15.3 x 2.2 mm (0.60 x 0.09 in.) (part no. 401 133)

In the case of threaded flange M18x1.5-6g provide a screw hole based on ISO 6149-1 (Fig. 13). See ISO 6149-1 for further information.

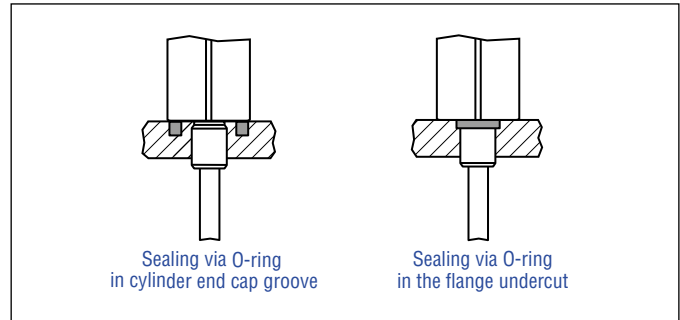


Fig. 12: Possibilities of sealing for threaded flange with flat-face

Hydraulics sealing for threaded flange with raised-face

Seal the flange contact surface by using an O-ring in the undercut (Fig. 11):

- For threaded flange (¾"-16 UNF-3A) »G« / »T«:
 O-ring 16.4 x 2.2 mm (0.65 x 0.09 in.) (part no. 560 315)
- For threaded flange (M18x1.5-6g) »N«:
 O-ring 15.3 x 2.2 mm (0.60 x 0.09 in.) (part no. 401 133)

- Note the fastening torque of 50 Nm.
- Seat the flange contact surface completely on the cylinder mounting surface.
- The cylinder manufacturer determines the pressure-resistant gasket (copper gasket, O-ring, etc.).
- The position magnet should not grind on the sensor rod.
- The piston rod drilling (TH-F / -G / -M / -N / -S / -T / -W: ≥ Ø 13 mm (≥ Ø 0.51 in.)) depends on the pressure and piston speed.
- Adhere to the information relating to operating pressure.
- Protect the sensor rod against wear.

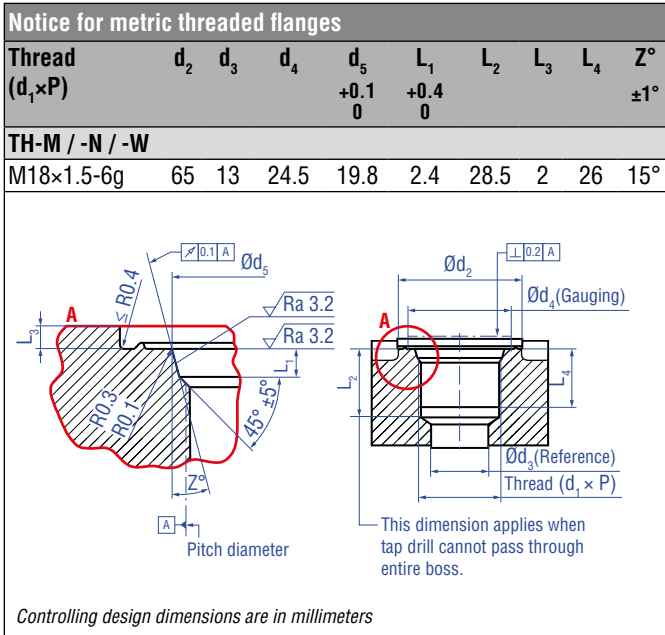


Fig. 13: Notice for metric threaded flange M18×1.5-6g based on DIN ISO 6149-1

4.3 Magnet installation

Typical use of magnets




Magnet	Benefits
Ring magnets 	<ul style="list-style-type: none"> Rotationally symmetrical magnetic field
U-magnets 	<ul style="list-style-type: none"> Height tolerances can be compensated, because the magnet can be lifted off
Floats 	<ul style="list-style-type: none"> For liquid level measurement

Fig. 14: Typical use of magnets

Mounting ring magnets & U-magnets

Install the magnet using non-magnetic material for mounting device, screws, spacers etc.. The magnet must not grind on the sensor rod. Alignment errors are compensated via the air gap.

- Permissible surface pressure: Max. 40 N/mm²
- Fastening torque for M4 screws: 1 Nm; use washers, if necessary
- Minimum distance between position magnet and any magnetic material has to be 15 mm (0.6 in.) (Fig. 16).
- If no other option exists and magnetic material is used, observe the specified dimensions (Fig. 16).

Controlling design dimensions are in millimeters and measurements in () are in inches

NOTICE

Mount ring magnets and U-magnets concentrically. The maximum permissible air gap must not be exceeded (Fig. 15). Take care to mount the primary sensor axis in parallel to the magnet path in order to avoid damage to the carriage, magnet and sensor rod.

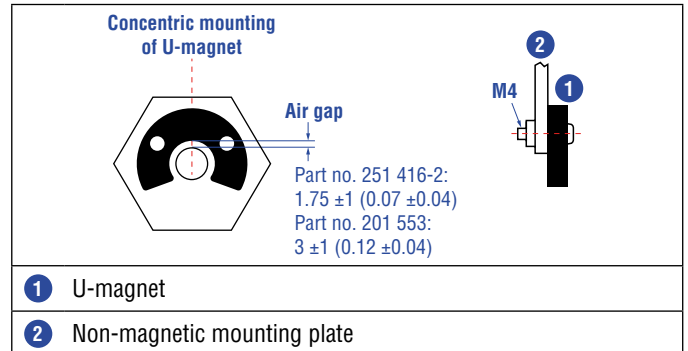


Fig. 15: Mounting of U-magnet (part no. 251 416-2 or part no. 201 553)

Magnet mounting with magnetic material

When using magnetic material the dimensions of Fig. 16 must be observed.

- If the position magnet aligns with the drilled piston rod
- If the position magnet is set further into the drilled piston rod, install another non-magnetic spacer (e.g. part no. 400 633) above the magnet.

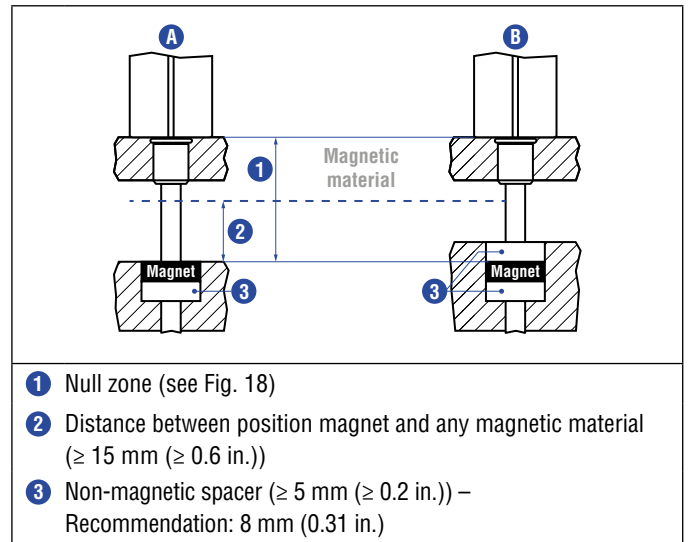


Fig. 16: Installation with magnetic material

Sensors with stroke lengths ≥ 1 meter (3.3 ft.)

Support horizontally installed sensors with a stroke length from 1 meter (3.3 ft.) mechanically at the rod end. Without the use of a support, rod and position magnet may be damaged. A false measurement result is also possible. Longer rods require evenly distributed mechanical support over the entire length (e.g. part no. 561 481). Use an U-magnet (Fig. 17) for measurement.

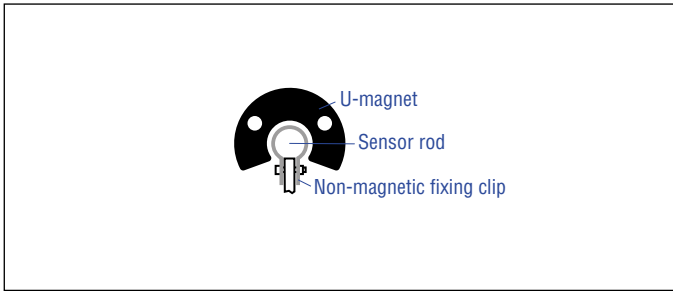


Fig. 17: Example of sensor support (part no. 561 481)

Start and end positions of the position magnets

Consider the start and end positions of the position magnets during the installation. To ensure that the entire stroke length is electrically usable, the position magnet must be mechanically mounted as follows.

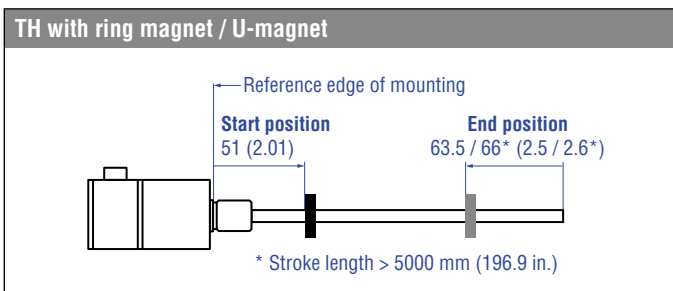


Fig. 18: Start and end positions of magnets

NOTICE

On all sensors, the areas left and right of the active stroke length are provided for null and dead zone. These zones should not be used for measurement, however the active stroke length can be exceeded.

Differentiation measurement

For a differentiation measurement two positions are measured on the sensor rod. The distance between these positions will be output.

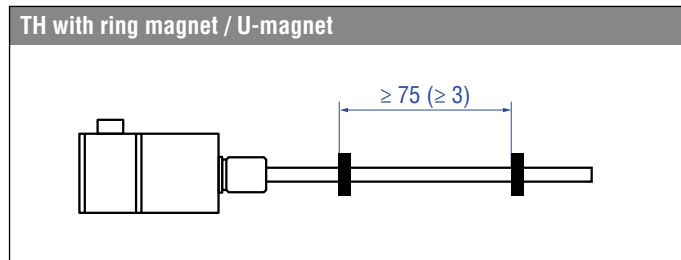


Fig. 19: Minimum distance between magnets for differentiation measurement

NOTICE

Do not go below a minimal distance of 75 mm (3 in.) between the magnets for differentiation measurement. ⁴ Use magnets of the same type (e.g. two ring magnets with part no. 201 542-2) for differentiation measurement.

Mounting floats

A stop collar is ordered separately with a float. The stop collar consists of material, which is below the specific gravity of the fluid. It is designed to keep the float out of the dead zone. The placement of the stop collar is dependent on the float and placement of the magnet within the float. If your application requires measuring to the bottom of your vessel, ask MTS Sensors about our low lift-off float option.

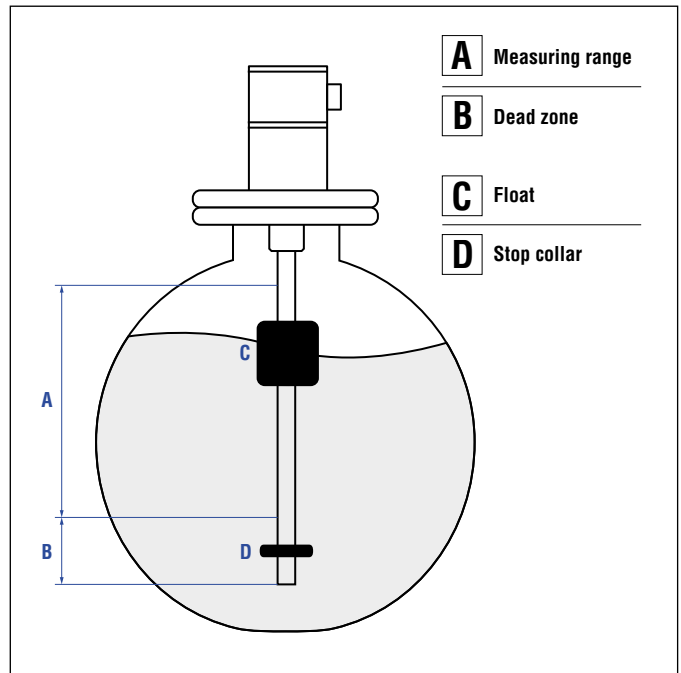


Fig. 20: Liquid level measurement

Controlling design dimensions are in millimeters and measurements in () are in inches

4/ Contact MTS Sensors if you need a magnet distance, which is smaller than 75 mm (3 in.)

4.4 Electrical connection

Placement of installation and cabling have decisive influence on the sensor's electromagnetic compatibility (EMC). Hence correct installation of this active electronic system and the EMC of the entire system must be ensured by using shielded cables and grounding. Overvoltages or faulty connections can damage the sensor electronics – despite protection – against wrong polarity.

NOTICE

1. Do not mount the sensors in the area of strong magnetic or electric noise fields.
2. Never connect / disconnect the sensor when voltage is applied.

Instruction for connection

- Remove the cover plate as shown in Fig. 6 on page 13 to connect the cables to the sensor.
- If you use a cable / cable gland use low-resistance twisted pair and shielded cables. Connect the shield to ground externally via the controller equipment.
- Keep control and signal leads separate from power cables and sufficiently far away from motor cables, frequency inverters, valve cables, relays, etc..
- Install a conductor of 4 mm² cross section to one of the two external ground lugs.
- Keep all non-shielded leads as short as possible.
- Keep the ground connections as short as possible with a large cross section. Avoid ground loops.
- Use only stabilized power supplies in compliance with the specified electrical ratings.

NOTICE

The contactable cross section is 0.2...2.5 mm² and 0.2...1.5 mm². Only 1 wire per clamping point is allowed!

Grounding of rod sensors

Connect the sensor electronics housing to machine ground. Ground sensor type TH via one of the two ground lugs as shown in Fig. 21. Refer also to the information given in chapter "2.3 Installation, commissioning and operation" on page 4.

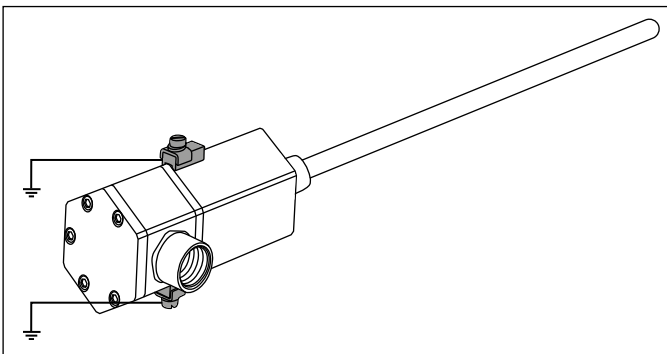


Fig. 21: Grounding via ground lug

Connector wiring

Connect the sensor directly to the control system, indicator or other evaluating systems as follows:

Version E & N suitable for connection types: C01, C10, M01, M10, N01, N10		
Signal + power supply		
Terminal	Pin	Function
	1	Data (-)
	2	Data (+)
	3	Clock (+)
	4	Clock (-)
	5	+24 VDC (-15 / +20 %)
	6	DC Ground (0 V)
	7	Cable shield

Fig. 22: TH (version E & N) wiring diagram (1.5 mm² conductor)

Version D & G suitable for connection types: C01, C10, N01, N10		
Signal + power supply		
Terminal	Pin	Function
	1	Data (-)
	2	Data (+)
	3	Clock (+)
	4	Clock (-)
	5	+24 VDC (-15 / +20 %)
	6	DC Ground (0 V)
	7	Cable shield

Fig. 23: TH (version D & G) wiring diagram (2.5 mm² conductor)

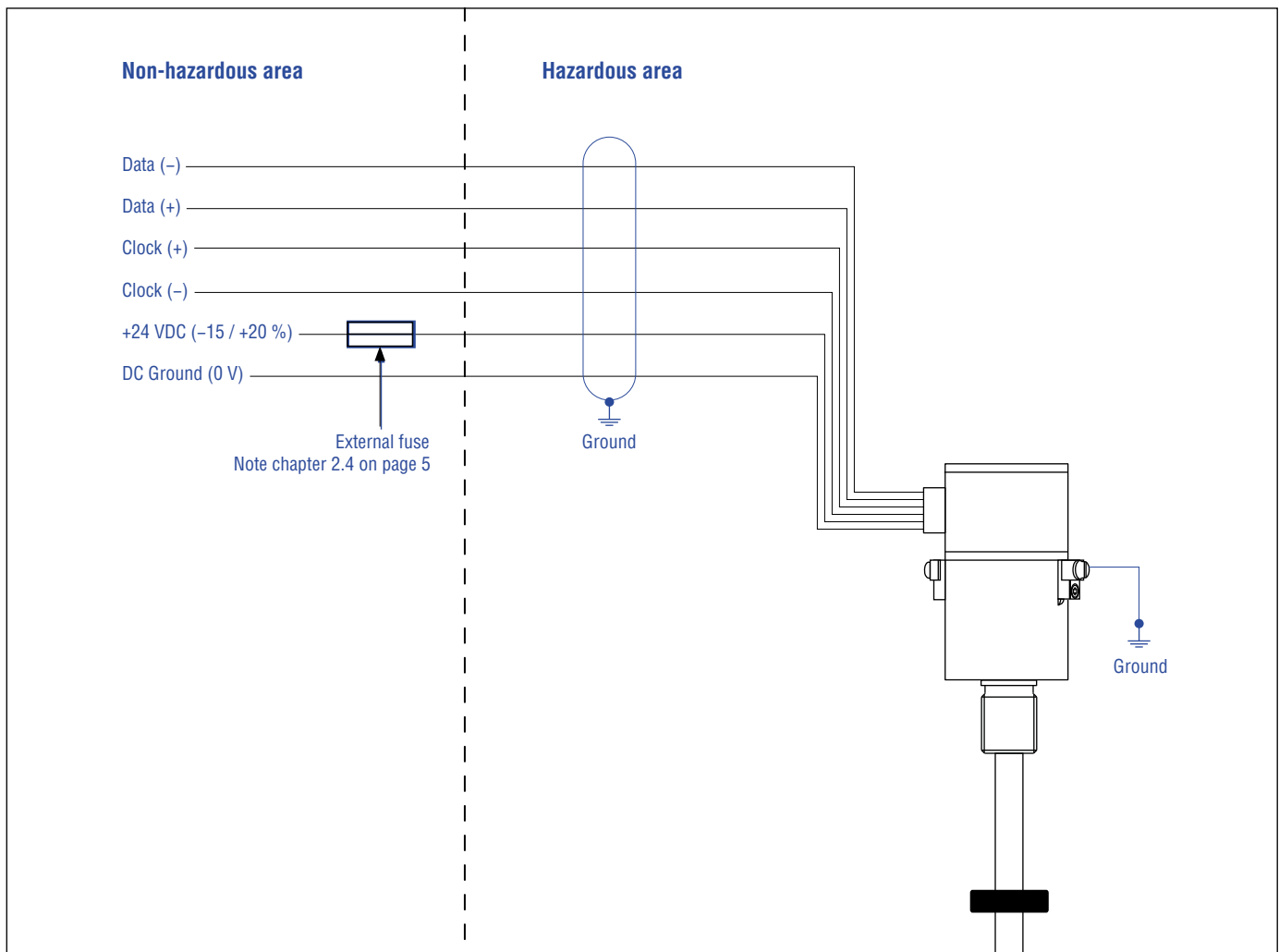




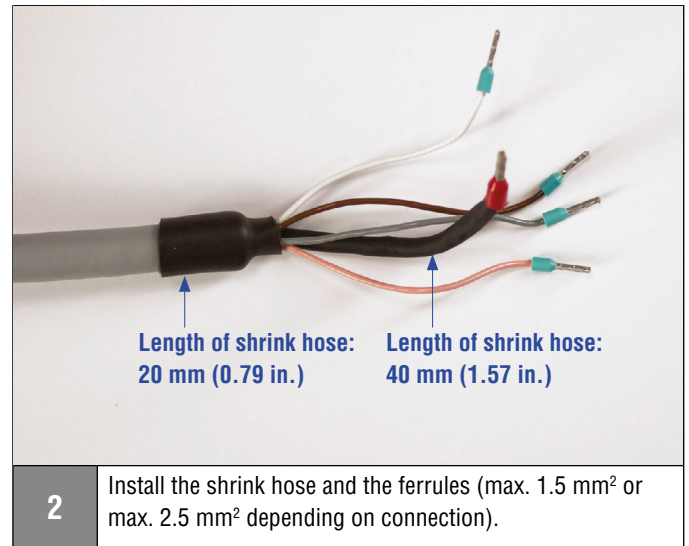
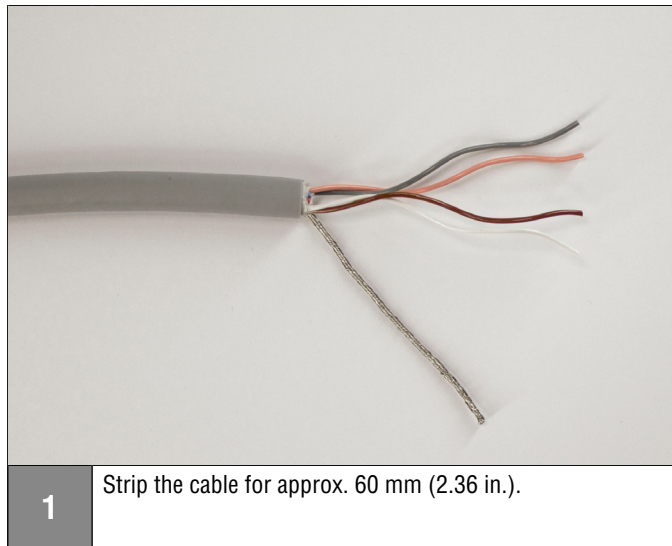


Fig. 24: Installation wiring diagram for side connection and top connection (example: Side connection)

Cable connection (only for versions E and N)

Recommended tools			
			
Electric torque screwdriver	Torque wrench	Slotted screwdriver	Crimping tool
3 mm (0.12 in.), fastening torque 1.2 Nm	Torque depending on cable gland	2.0 × 40 mm (0.08 × 1.57 in.)	For ferrules with max. 2.5 mm ²

Step 1: Preparing of cable



The following two options present how to connect the cable to the T-Series sensor:

- Option 1:** Cable connection via disassembly of connection adapter (see page 22)
- Option 2:** Cable connection without disassembly of connection adapter (see page 23)

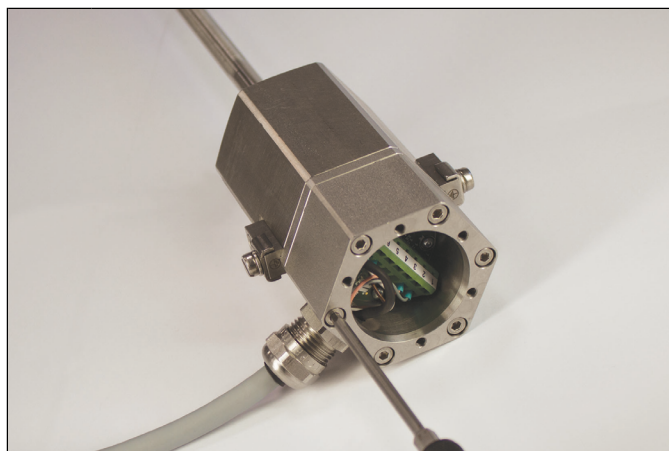
NOTICE
The example “Cable connection” is only valid for versions E and N of the TH sensor. Refer to the corresponding installation requirements and local regulations, if you like to connect a cable to the TH sensor versions D and G.

*The figures are examples.
Variations are possible, e.g. different cable colors*

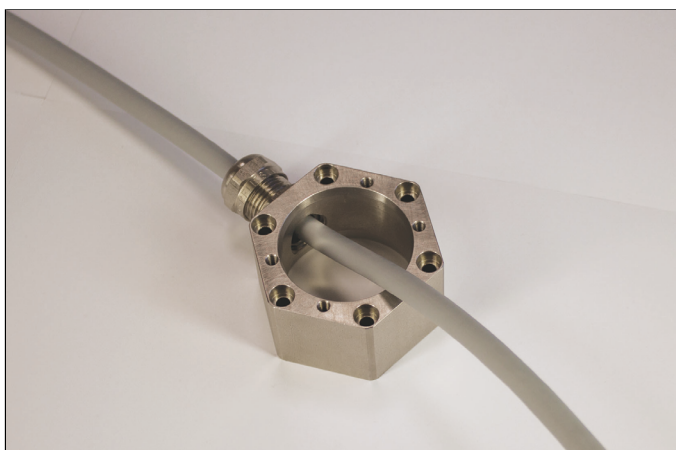
Step 2: Cable connection (Option 1: Disassembly of connection adapter)



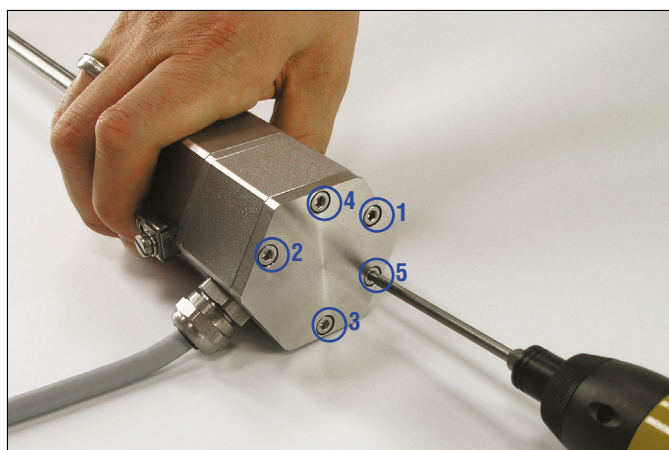
1 Loosen the five M4×10 screws (A/F 3). Remove the upper lid. Loosen the six M4×40 screws (A/F 3) of the connection adapter. Remove the connection adapter. See also Fig. 6.



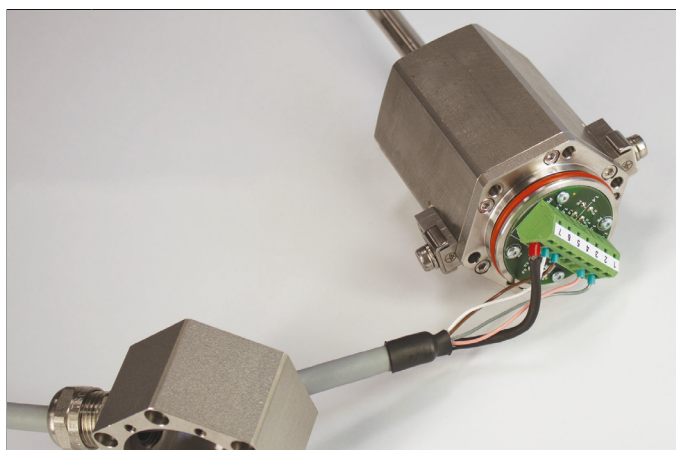
4 Inspect surfaces and O-ring for damage. Wipe surfaces clean and apply O-ring lube. Tighten the screws of the connection adapter with a fastening torque of 1.2 Nm.



2 Mount the cable gland at the connection adapter. Note the instructions given by the manufacturer of the cable gland!



5 Inspect surfaces and O-ring for damage. Wipe surfaces clean and apply O-ring lube. Check the position of O-ring between upper lid and connection adapter. Tighten the screws of the upper lid crosswise with a fastening torque of 1.2 Nm (see figure for right sequence).



3 Connect the cable to the sensor. Note the connection wiring on page 19.

NOTICE

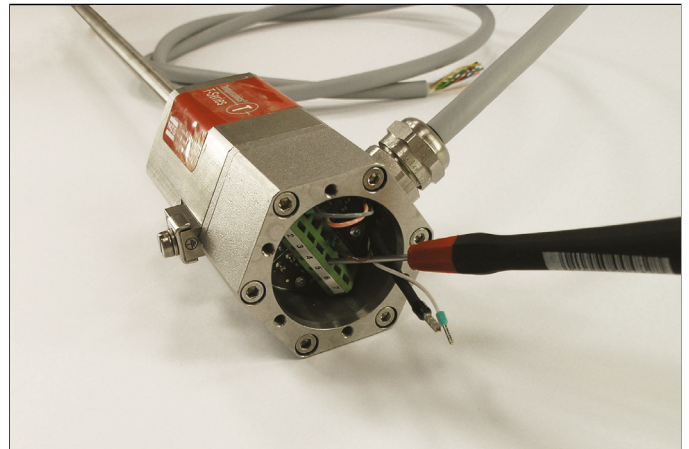
The example “Cable connection” is only valid for versions E and N of the TH sensor. Refer to the corresponding installation requirements and local regulations, if you like to connect a cable to the TH sensor versions D and G.

*The figures are examples.
 Variations are possible, e.g. different cable colors*

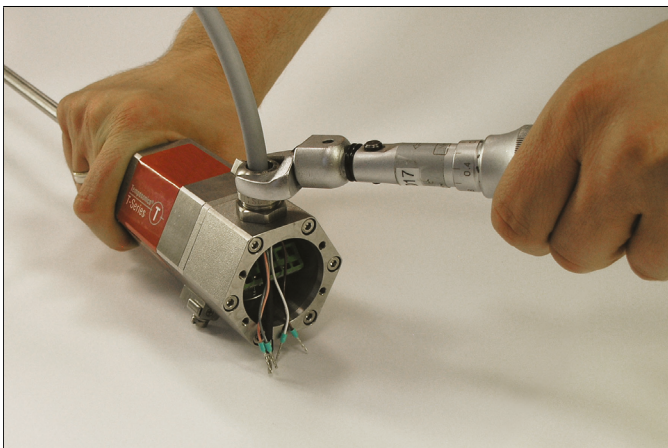
Step 2: Cable connection (Option 2: Without disassembly of connection adapter)



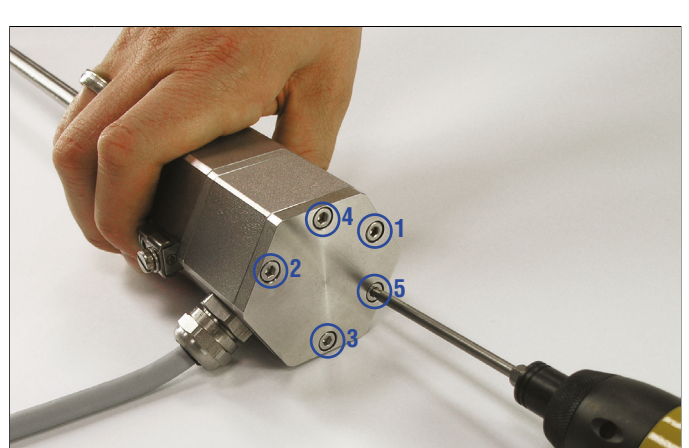
1 Loosen the five M4×10 screws (A/F 3).



3 Connect the cable to the sensor.
Note the connection wiring on page 19.



2 Mount the cable and cable gland. Note the instructions given by the manufacturer of the cable gland!



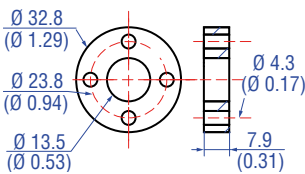
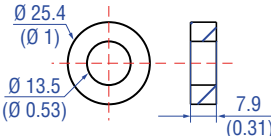
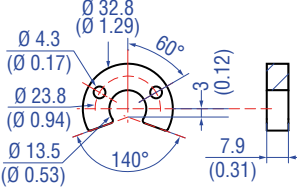
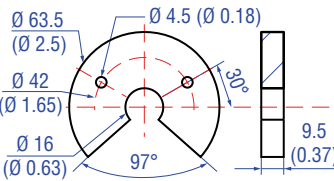
4 Inspect surfaces and O-ring for damage. Wipe surfaces clean and apply O-ring lube. Check the position of O-ring between upper lid and connection adapter. Tighten the screws of the upper lid crosswise with a fastening torque of 1.2 Nm (see figure for right sequence).

NOTICE
The example “Cable connection” is only valid for versions E and N of the TH sensor. Refer to the corresponding installation requirements and local regulations, if you like to connect a cable to the TH sensor versions D and G.

*The figures are examples.
Variations are possible, e.g. different cable colors*

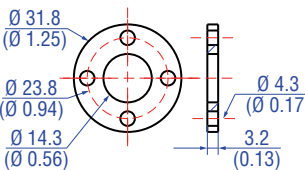
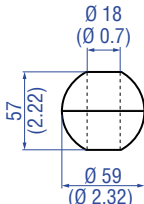
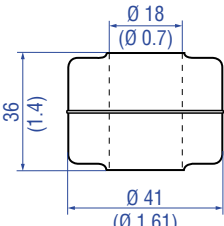
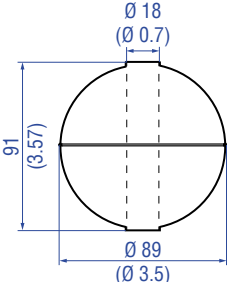
4.5 Frequently ordered accessories – Additional options available in our [Accessories Guide](#) 551444

Position magnets

			
<p>Ring magnet OD33 Part no. 201 542-2</p> <p>Material: PA ferrite GF20 Weight: Approx. 14 g Surface pressure: Max. 40 N/mm² Fastening torque for M4 screws: 1 Nm Operating temperature: -40...+105 °C (-40...+221 °F)</p>	<p>Ring magnet OD25.4 Part no. 400 533</p> <p>Material: PA ferrite Weight: Approx. 10 g Surface pressure: Max. 40 N/mm² Operating temperature: -40...+105 °C (-40...+221 °F)</p>	<p>U-magnet OD33 Part no. 251 416-2</p> <p>Material: PA ferrite GF20 Weight: Approx. 11 g Surface pressure: Max. 40 N/mm² Fastening torque for M4 screws: 1 Nm Operating temperature: -40...+105 °C (-40...+221 °F)</p>	<p>U-magnet OD63.5 Part no. 201 553</p> <p>Material: PA 66-GF30, magnets compound-filled Weight: Approx. 26 g Surface pressure: 20 N/mm² Fastening torque for M4 screws: 1 Nm Operating temperature: -40...+75 °C (-40...+167 °F)</p>

Magnet spacer

Floats⁵

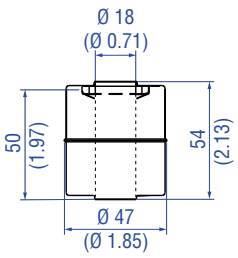
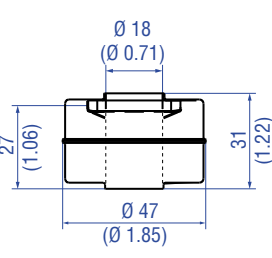
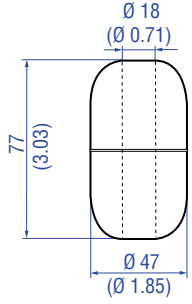
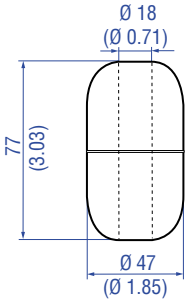
			
<p>Magnet spacer Part no. 400 633</p> <p>Material: Aluminum Weight: Approx. 5 g Surface pressure: Max. 20 N/mm² Fastening torque for M4 screws: 1 Nm</p>	<p>Float Part no. 251 387-2</p> <p>Material: Stainless steel (AISI 316L) Weight offset: Yes Pressure: 22.4 bar (325 psi) Magnet offset: No Specific gravity: Max. 0.48 Operating temperature: -40...+125 °C (-40...+257 °F)</p>	<p>Float Part no. 200 938-2</p> <p>Material: Stainless steel (AISI 316L) Weight offset: Yes Pressure: 8.6 bar (125 psi) Magnet offset: No Specific gravity: Max. 0.74 Operating temperature: -40...+125 °C (-40...+257 °F)</p>	<p>Float Part no. 251 469-2</p> <p>Material: Stainless steel (AISI 316L) Weight offset: Yes Pressure: 29.3 bar (425 psi) Magnet offset: No Specific gravity: Max. 0.45 Operating temperature: -40...+125 °C (-40...+257 °F)</p>

Controlling design dimensions are in millimeters and measurements in () are in inches

- 5/ • Be sure that the float specific gravity is at least 0.05 less than that of the measured liquid as a safety margin at ambient temperature
- For interface measurement: A minimum of 0.05 specific gravity differential is required between the upper and lower liquids
- When the magnet is not shown, the magnet is positioned at the center line of float

- An offset weight is installed in the float to bias or tilt the float installed on the sensor tube. So the float remains in contact with the sensor tube at all times and guarantees permanent potential equalization of the float. The offset is required for installations that must conform to hazardous location standards

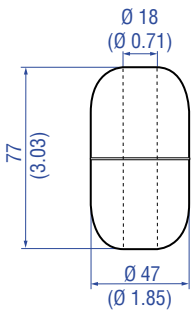
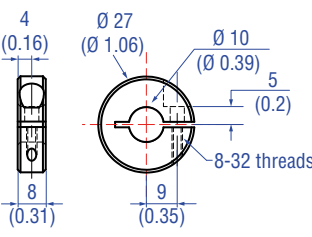
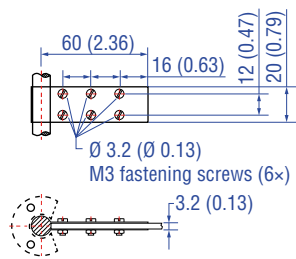
Floats⁶

			
<p>Float Part no. 201 605-2</p> <p>Material: Stainless steel 1.4571 (AISI 316 Ti) Weight offset: Yes Pressure: 4 bar (60 psi) Magnet offset: Yes Specific gravity: Max. 0.6 Operating temperature: -40...+125 °C (-40...+257 °F)</p> <p>Standard float that can be expedited</p>	<p>Float Part no. 201 606-2</p> <p>Material: Stainless steel 1.4571 (AISI 316 Ti) Weight offset: Yes Pressure: 4 bar (60 psi) Magnet offset: Yes Specific gravity: 0.93 ± 0.01 Operating temperature: -40...+125 °C (-40...+257 °F)</p> <p>Standard float that can be expedited</p>	<p>Float Part no. 251 982-2</p> <p>Material: Stainless steel (AISI 316L) Weight offset: Yes Pressure: 29.3 bar (425 psi) Magnet offset: No Specific gravity: 0.93 ± 0.01 Operating temperature: -40...+125 °C (-40...+257 °F)</p>	<p>Float Part no. 251 983-2</p> <p>Material: Stainless steel (AISI 316L) Weight offset: Yes Pressure: 29.3 bar (425 psi) Magnet offset: No Specific gravity: 1.06 ± 0.01 Operating temperature: -40...+125 °C (-40...+257 °F)</p>

Float⁶

Collar

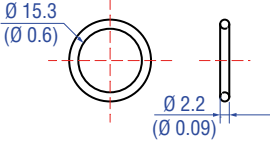
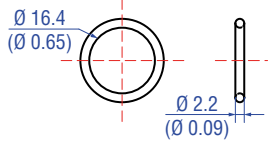

Optional installation hardware

		
<p>Float Part no. 251 981-2</p> <p>Material: Stainless steel (AISI 316L) Weight offset: Yes Pressure: 29.3 bar (425 psi) Magnet offset: No Specific gravity: Max. 0.67 Operating temperature: -40...+125 °C (-40...+257 °F)</p>	<p>Stop collar Part no. 560 777</p> <p>Provides end of stroke stops for float Material: Stainless steel 1.4301 (AISI 304) Weight: Approx. 30 g Hex key 7/64" required</p>	<p>Fixing clip Part no. 561 481</p> <p>Application: Used to secure sensor rods (Ø 10 mm (Ø 0.39 in.)) when using an U-magnet or block magnet Material: Brass, non-magnetic</p>

Controlling design dimensions are in millimeters and measurements in () are in inches

- Be sure that the float specific gravity is at least 0.05 less than that of the measured liquid as a safety margin at ambient temperature
- For interface measurement: A minimum of 0.05 specific gravity differential is required between the upper and lower liquids
- When the magnet is not shown, the magnet is positioned at the center line of float

- An offset weight is installed in the float to bias or tilt the float installed on the sensor tube. So the float remains in contact with the sensor tube at all times and guarantees permanent potential equalization of the float. The offset is required for installations that must conform to hazardous location standards

O-rings	Programming tool ⁷	
		
<p>O-ring for threaded flange M18x1.5-6g Part no. 401 133</p>	<p>O-ring for threaded flange 3/4"-16 UNF-3A Part no. 560 315</p>	<p>Programming kit Part no. 253 135-1 (EU) Part no. 253 310-1 (US)</p>
<p>Material: Fluoroelastomer Durometer: 75 ± 5 Shore A Operating temperature: -40...+204 °C (-40...+400 °F)</p>	<p>Material: Fluoroelastomer Durometer: 75 ± 5 Shore A Operating temperature: -40...+204 °C (-40...+400 °F)</p>	<p>Kit includes:</p> <ul style="list-style-type: none"> 1 × interface converter box, 1 × power supply 1 × cable (60 cm) with M16 female connector (7 pin), straight – D-sub female connector (9 pin), straight 1 × cable (60 cm) with 6 × terminal clamp – D-sub female connector (9 pin), straight 1 × USB cable <p>Software is available at: www.mtssensors.com</p>

Controlling design dimensions are in millimeters and measurements in () are in inches

7/ The programming tool is not approved for use in hazardous environments

5. Operation

5.1 Getting started

The sensor is factory-set to its order sizes and adjusted, i.e. the distance between magnet and flange is specified in resolution steps.
Example: SSI value 5000 with a resolution of 20 µm corresponds to a magnet distance of 100 mm from the flange

NOTICE If necessary, the SSI sensors can be re-adjusted using the service tool described below.

NOTICE

Observe during commissioning

1. Before initial switch-on, check carefully if the sensor has been connected correctly.
2. Position the magnet in the measuring range of the sensor during first commissioning and after replacement of the magnet.
3. Ensure that the sensor control system cannot react in an uncontrolled way when switching on.
4. Ensure that the sensor is ready and in operation mode after switching on.
5. Check the pre-set start and end positions of the measuring range (see Fig. 18) and correct them via the customer's control system or the MTS Sensors service tool, if necessary. The operation of the service tool is described in detail on the following pages.

5.2 Programming and configuration

SSI interface

The interface of Temposonics® position sensors corresponds to SSI industry standard for absolute encoders. Its displacement value is encoded in a 24 / 25 / 26 bit binary or gray format and transmitted as a differential signal in SSI standard (RS 422).

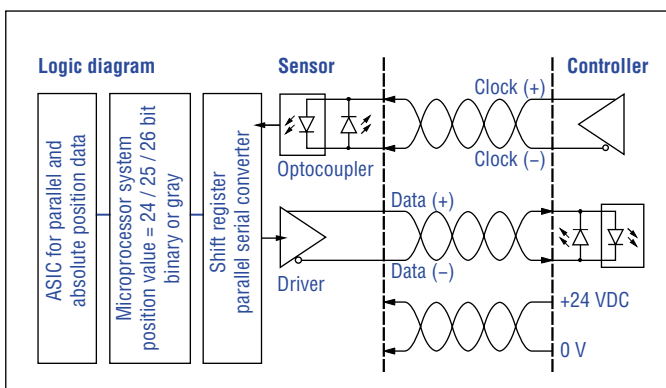


Fig. 25: Schematic connection

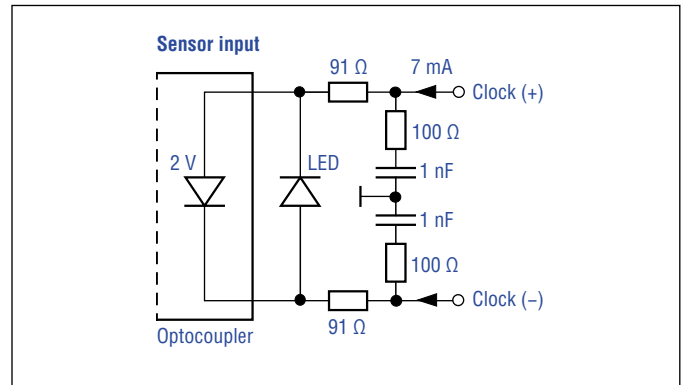


Fig. 26: Input wiring clock (+) / clock (-)

The absolute, parallel position data is continually updated by the sensor and converted by the shift-register into a serial bit stream (Fig. 27).

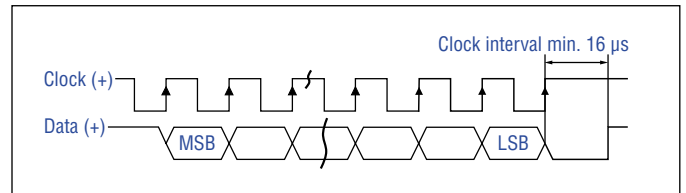


Fig. 27: Timing diagram

Dependent on the baud rate chosen in the controller the following cable lengths are possible (Fig. 28):

Cable length	< 3 m	< 50 m	< 100 m	< 200 m	< 400 m
Baud rate	1 MBd	< 400 kBd	< 300 kBd	< 200 kBd	< 100 kBd

Fig. 28: Cable lengths and related baud rates

MTS Sensors programming tool

Temposonics® position sensors can be adapted to modified measurement tasks very easily via the connecting leads – without opening the sensor. For this, the following MTS Sensors programming tool is available (see page 26).

NOTICE The programming tool is not approved for use in hazardous environments.

Programming kit, part no. 253 135-1 (EU) / 253 310-1 (US)

The PC programmer is a hardware converter between sensor and serial PC interface. It can be used for adjusting sensor parameters via computer and the MTS Sensors programming software. The software for reading and adjusting the sensors requires a Windows computer with a free USB port. You can adjust the following parameters:

- Data length and data format (optionally with parity- and error bit)
- Resolution and measuring direction
- Synchronous / asynchronous measurement
- Offset, begin of the measurement range
- Alarm value (magnet was removed, magnet is missing)
- Measurement filter (moving average of 2, 4 or 8 measurements for noise reduction)
- Velocity measurement or position measurement or differentiation measurement

Step 1: Connect PC programmer

- Step 2: Install software
- Step 3: Start program

- Connect the PC programmer with the sensor via the corresponding adapter cable.
- Connect the PC programmer to a USB port of the computer.
- Connect the power supply via connector.
- The outer contact of the connector is 0 V (ground), the inner contact is 24 VDC.

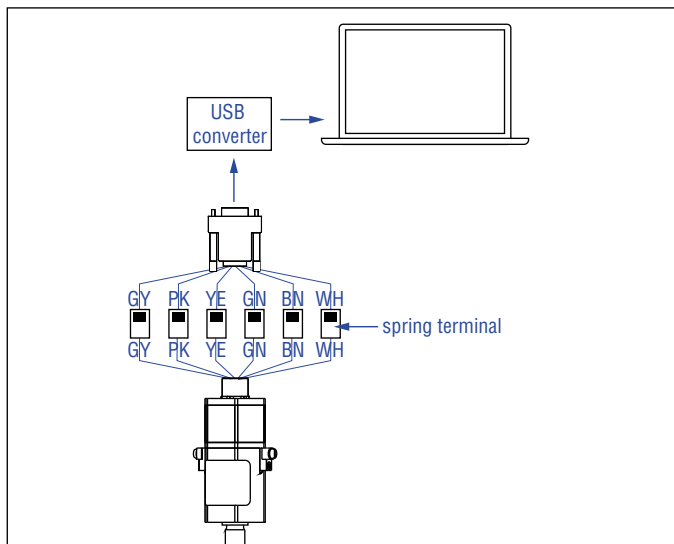


Fig. 29: Connect PC programmer

NOTICE

Never connect / disconnect the sensor when voltage is applied.

- Step 1: Connect PC programmer
- Step 2: Install software**
- Step 3: Start program

Download current software version from www.mtssensors.com. Copy the program SSIConfigurator.exe to your computer and start it by double-clicking on it. The program now displays a list of available COMs. Normally, the COM port with the lowest number (e.g. COM1) should be selected. If a connection fails, it could be a missing driver. In this case, download and install the USB serial converter driver from www.mtssensors.com.

- Step 1: Connect PC programmer
- Step 2: Install software
- Step 3: Start program**

After starting the MTS SSI-Configurator, the user interface of the connected sensor with its adjustable parameters will open (Fig. 30).

MTS SSI-Configurator user interface

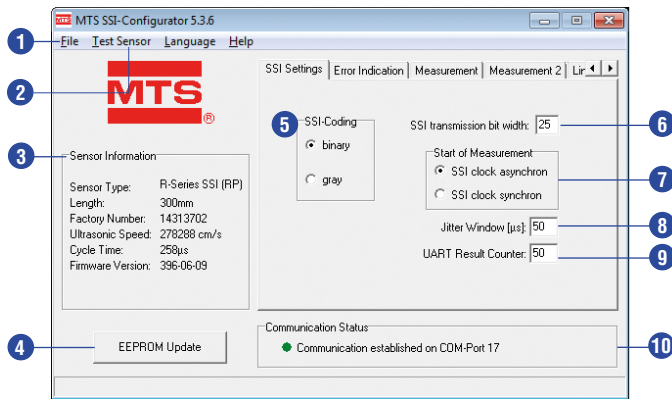


Fig. 30: MTS SSI-Configurator, SSI Settings

- 1 In the **File** menu, you can save the sensor configuration on hard disk, print it out or load it into the sensor. Moreover, this menu permits returning to the factory setting.
- 2 Via **Test Sensor** the position of the magnet is displayed graphically. (Fig. 31).
- 3 Frame **Sensor Information** contains the invariable sensor parameters, which are read in automatically when connecting the sensor.
- 4 Click on **EEPROM Update** to send and store altered parameters (highlighted with a blue background) permanently in the sensor. Subsequently, the stored values are displayed again with a white background.
- 5 Use the option box **binary** or **gray** to determine the SSI coding.
- 6 In this field you can set the **SSI transmission bit width** for the position output.
- 7 Use the option box **SSI clock asynchron** and **SSI clock synchron** to change the start of measurement.

MTS SSI-Configurator		T-Series order code
SSI clock asynchron	complies with	Asynchronous mode
SSI clock synchron	complies with	Synchronous mode 1

In asynchronous mode the sensor starts measuring and provides the position independent of the PLC.
In “synchronous mode 1” the output of the position of the Temposonics® SSI sensor is matched to the data request cycle of the controller. The contouring error complies with the cycle time of the stroke length.

- 8 The jitter specifies the time interval between the start of measuring and the SSI clock, which is given by the PLC (for “SSI clock synchron”).
- 9 Via **UART Result Counter** you define a time interval for the function **Test Sensor** to send a position value Fig. 31 (graphical presentation of position values). Example: If you choose “50” in the field **UART Result Counter**, each 50. measurement will be displayed.
- 10 **Communication Status** indicates that the sensor is connected successfully.

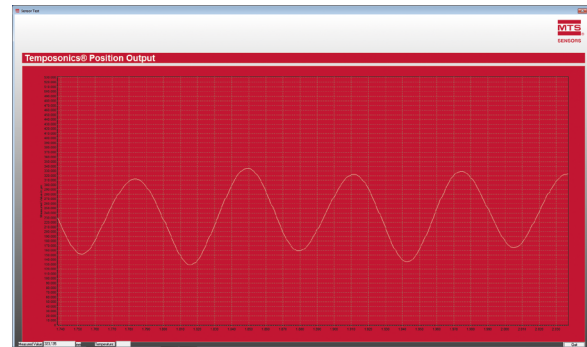


Fig. 31: Graphical display of position values via Test Sensor

Tab “Error Indication”

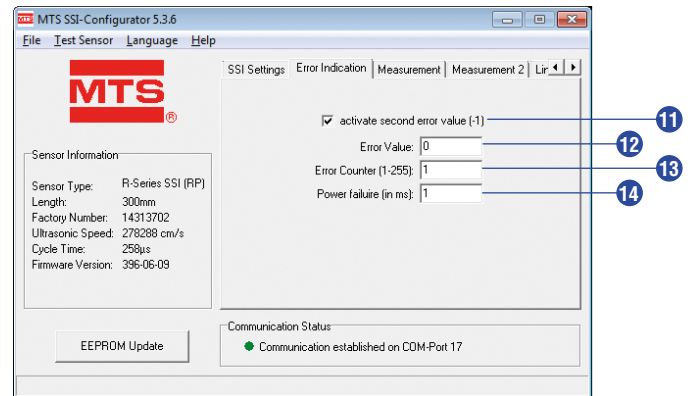


Fig. 32: MTS SSI-Configurator, Error Indication

- 11 If the check box **activate second error value (-1)** is active, an error value of “-1” is output if the sensor is used with more magnets as specified before. If the check box is not active and the sensor is used with more magnets as specified before, the value which was defined in field **Error Value** will be displayed. The **Error Value** will also display if the sensor is used with less magnets as determined before.
- 12 In the case of failure the sensor transmits the **Error Value**.
- 13 Use the field **Error Counter** to determine how often in the case of failure (1...255 times) the old measurement value will be repeated, before the **Error Value** will be displayed.

MTS SSI-Configurator		T-Series order code
Error counter	complies with	Error delay

- 14 In this field you can define a period (1...100 ms), during which the power supply of the sensor can be fallen short of, without the **Error Value** to display. Set the value to “0” to deactivate the function **Power failure (in ms)**.

Tab “Measurement”

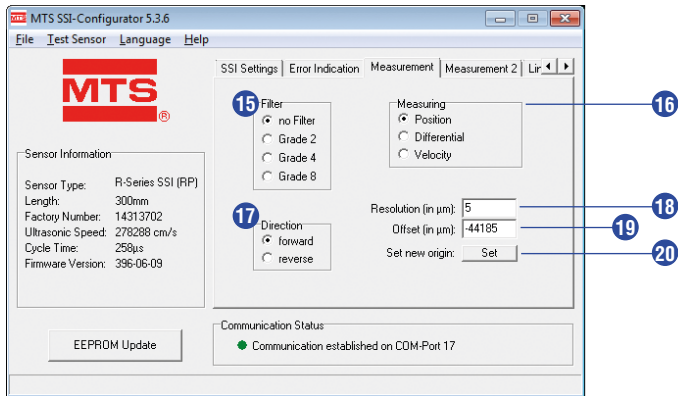


Fig. 33: MTS SSI-Configurator, Measurement

Tab “Measurement 2”

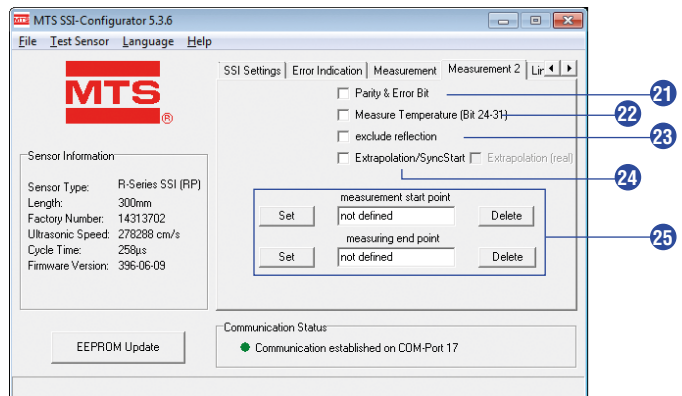


Fig. 34: MTS SSI-Configurator, Measurement 2

- 15 Use the field **Filter** to choose a noise reduction filter of two, four or eight measurements. You can adjust the filter via the MTS SSI-Configurator and adapt it to your application.
- 16 In the field **Measuring** you can choose between the following options:
Position: Measurement and output of position value
Differential: Measurement of two positions and output of the distance between them.
Velocity: Measurement and output of velocity of the position magnet, which moves over the sensor rod or the sensor profile.
- 17 Via **Direction** you can determine the measuring direction.
Forward: Ascending position values from sensor electronics housing to rod end
Reverse: Ascending position values from rod end to sensor electronics housing
- 18 In the field **Resolution (in µm)** you can set the resolution of the sensor. See technical data on page 33 for resolution steps.
- 19 **Offset (in µm)** shows the offset which was determined during the sensor end control at the factory. You can change the offset (null position) in entering a new value in the field **Offset (in µm)**. After that you have to press the button **EEPROM Update** to confirm. Another possibility is described in 20.
- 20 If you like to change the offset, move the magnet into the desired position. Confirm the position via the button **Set**.
 The factory settings can be restored at any time under the menu item **File**.

NOTICE If the measuring direction changes, the offset will be converted automatically. If the null position moves into the measuring range, values < 0 of the binary data format will be output as negative.

- | MTS SSI-Configurator | T-Series order code |
|----------------------|---------------------------------------|
| Parity bit | complies with Parity even bit: 26 bit |
| Error bit | complies with Alarm bit: 25 bit |
- 21 If the checkbox is activated, bit 25 is output as error bit and bit 26 as parity bit. In this case the SSI bit width for transferring the position data is limited to 24 bit. The **Parity & Error Bit** influences the cycle time of the synchronous measurement. You cannot choose **Parity & Error Bit** and **Measure Temperature (Bit 24-31)** at the same time.
 - 22 If the checkbox is activated the temperature measured in the sensor electronics housing will be output (bit 25-32). In this case the SSI bit width for transferring the position data is limited to 24 bit. You cannot choose **Parity & Error Bit** and **Measure Temperature (Bit 24-31)** at the same time.
 - 23 Activate the check box to exclude reflections of the position measurement. Thus the cycle time extends.
 - 24 To select the “synchronous mode 2” activate **SSI clock synchron** in SSI settings first. After that activate the check box **Extrapolation/SyncStart**.

MTS SSI-Configurator	T-Series order code
Extrapolation/SyncStart	complies with Synchronous mode 2

- The “synchronous mode 2” is most suitable for applications where the polling cycle of the controller can be faster than the measurement cycle time of the Temposonics® SSI sensor. The values for the PLC will be oversampled up to 10 kHz. The delay is similar to the asynchronous mode.
- 25 In the field **measurement start point** and **measurement end point** you can define a new working area. Move the magnet to the desired position and click **Set** to define a new measurement start or end point. Via the button **Delete** you can delete the measurement start and end point again. The current position of the magnet is displayed within the working area, a magnet outside of the working area will be ignored.

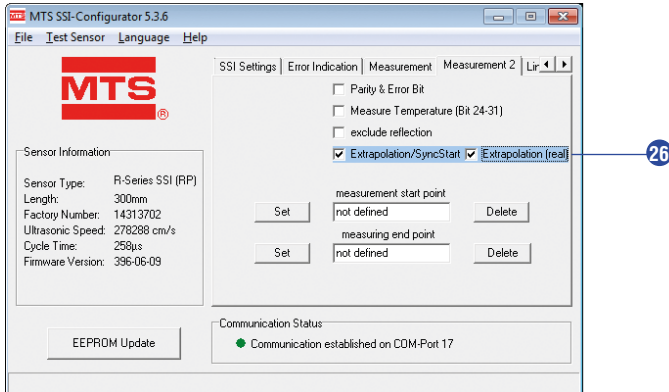


Fig. 35: MTS SSI-Configurator, Measurement 2, choose “synchronous mode 3”

26 To select the “synchronous mode 3”, activate the check box **Extrapolation/SyncStart** first and after that **Extrapolation (real)**. The function of the “synchronous mode 3” is similar to “synchronous mode 2”. For “synchronous mode 3” each delay will be compensated.

MTS SSI-Configurator		T-Series order code
Extrapolation (real)	complies with	Synchronous mode 3

6. Maintenance and troubleshooting

6.1 Error conditions, troubleshooting

See 11 and 12 on page 29.

6.2 Maintenance

The required inspections need to be performed by qualified personnel according to IEC 60079-17 / TRBS 1203. These inspections should include at least a visual inspection of the housing, associated electrical equipment entrance points, retention hardware and equipment grounding. Inside the Ex-atmosphere the equipment has to be cleaned regularly. The user determines the intervals for checking according to the environmental conditions present at the place of operation. After maintenance and repair, all protective devices removed for this purpose must be refitted.

Type of inspection	Visual inspection every 3 months	Close inspection every 6 months	Detailed inspection every 12 months
Visual inspection of the sensor for intactness, removal of dust deposits	●		
Check of electrical system for intactness and functionality			●
Check of entire system	User's responsibility		

Fig. 36: Schedule of inspection

NOTICE

Perform maintenance work that requires a dismantling of the system only in an Ex-free atmosphere. If this is not possible take protective measures in compliance with local regulations.

Maintenance: Defines a combination of any actions carried out to retain an item in, or restore it to, conditions in which it is able to meet the requirements of the relevant specification and perform its required functions.

Inspection: Defines an activity with the purpose of checking a product carefully, aiming at a reliable statement of the condition of the product. The inspection is carried out without dismantling, or, if necessary, with partial dismantling, and supplemented by other measures, e.g. measurements.

Visual inspection: Optical inspection of product aims at the recognition of visible defects like missing bolts without using auxiliary equipment and tools.

Close inspection: Defines an inspection which encompasses those aspects covered by a visual inspection and, in addition, identifies those defects, such as loose bolts, which will be apparent only by the use of access equipment, for example steps, where necessary, and tools.

Detailed inspection: Defines an inspection which encompasses those aspects covered by a close inspection and, in addition, identifies those defects, such as loose terminations, which will only be apparent by opening the enclosure, and / or using, where necessary, tools and test equipment.

6.3 Repair

Repairs of the sensor may only be performed by MTS Sensors or a repair facility explicitly authorized by MTS Sensors. Repairs of the flameproof joints must be made by the manufacturer in compliance with the constructive specifications. Repairs must not be made on the basis of values specified in tables 1 and 2 of IEC/EN 60079-1.

6.4 List of spare parts

No spare parts are available for this sensor.

6.5 Transport and storage

Note the storage temperature of the sensor, which is from -40...+93 °C (-40...+200 °F).

7. Removal from service / dismantling

The product contains electronic components and must be disposed of in accordance with the local regulations.

8. Technical data Temposonics® TH

Output													
Interface	SSI (Synchronous Serial Interface) – differential signal in SSI standard (RS 422)												
Data format	Binary or gray, optional parity and error bit or temperature of sensor electronics												
Data length	8...32 bit												
Data transmission rate	70 kBaud ⁸ ...1 MBaud, depending on cable length: <table border="1" style="width: 100%; border-collapse: collapse;"> <tr> <td style="text-align: left;">Cable length</td> <td>< 3 m</td> <td>< 50 m</td> <td>< 100 m</td> <td>< 200 m</td> <td>< 400 m</td> </tr> <tr> <td style="text-align: left;">Baud rate</td> <td>1 MBd</td> <td>< 400 kBd</td> <td>< 300 kBd</td> <td>< 200 kBd</td> <td>< 100 kBd</td> </tr> </table>	Cable length	< 3 m	< 50 m	< 100 m	< 200 m	< 400 m	Baud rate	1 MBd	< 400 kBd	< 300 kBd	< 200 kBd	< 100 kBd
Cable length	< 3 m	< 50 m	< 100 m	< 200 m	< 400 m								
Baud rate	1 MBd	< 400 kBd	< 300 kBd	< 200 kBd	< 100 kBd								
Measured value	Position, differentiation measurement, velocity, temperature of sensor electronics												
Measurement parameters													
Resolution	Position: 0.5 µm, 1 µm, 2 µm, 5 µm, 10 µm, 20 µm, 50 µm, 100 µm / Velocity over 10 measured values: 0.1 mm/s (at 1 ms cycle time)												
Cycle time	Stroke length 300 mm 750 mm 1000 mm 2000 mm 5000 mm Measurement rate 3.7 kHz 3.0 kHz 2.3 kHz 1.2 kHz 0.5 kHz												
Linearity deviation ⁹	< ±0.01 % F.S. (minimum ±40 µm)												
Repeatability	< ±0.001 % F.S. (minimum ±2.5 µm) typical												
Hysteresis	< 4 µm typical												
Temperature coefficient	< 15 ppm/K typical												
Operating conditions													
Operating temperature	–40...+75 °C (–40...+167 °F)												
Humidity	90 % relative humidity, no condensation												
Ingress protection	Version D, G, and E: IP66 / IP67 (if properly connected by means that support IP66 / IP67 (pipe, gland, etc.)) Version N: IP66, IP67, IP68, IP69K, NEMA 4X, depending on cable gland												
Shock test	100 g / 6 ms, IEC standard 60068-2-27												
Repeated shock events	160 g / 2 ms, IEC standard 60068-2-27 (for shock improved option A , see order code for operating voltage on page 7)												
Vibration test	15 g / 10...2000 Hz, IEC standard 60068-2-6 (excluding resonant frequencies) ¹⁰												
EMC test	Electromagnetic emission according to EN 61000-6-3 Electromagnetic immunity according to EN 61000-6-2 The sensor meets the requirements of the EU directives and is marked with CE												
Operating pressure	350 bar static (5076 psi static)												
Magnet movement velocity ¹¹	Any												
Design / Material													
Sensor electronics housing	Stainless steel 1.4305 (AISI 303); option: Stainless steel 1.4404 (AISI 316L)												
Flange	See “Table 1: TH rod sensor threaded flange type references” on page 12												
Sensor rod	Stainless steel 1.4306 (AISI 304L); option: Stainless steel 1.4404 (AISI 316L)												
Stroke length	25...7620 mm (1...300 in.), 25...3760 mm (1...148 in.) for shock improved option												
Mechanical mounting													
Mounting position	Any												
Mounting instruction	Please consult the technical drawings on page 11												

See next page for “Electrical connection”

^{8/} With standard one shot of 16 µs

^{9/} With position magnet # 201 542-2

^{10/} Additional constraint hardware, customer supplied, and shock improved option A required for applications above 15 g. Contact MTS Sensors Applications Engineering

^{11/} If there is contact between the moving magnet including the magnet holder and the sensor rod, make sure that the maximum speed of the moving magnet is ≤ 1 m/s (Safety requirement due to ESD [Electro Static Discharge])

Electrical connection	
Connection type	T-Series terminal
Operating voltage	+24 VDC (-15 / +20 %)
Ripple	≤ 0.28 V _{pp}
Current consumption	100 mA typical
Dielectric strength	700 VDC (DC ground to machine ground)
Polarity protection	Up to -30 VDC
Overvoltage protection	Up to 36 VDC

Certifications

Certification required	Version E	Version D	Version G	Version N
IECEx / ATEX (IECEx: Global market; ATEX: Europe)	Ex db eb IIC T4 Ga/Gb Ex tb IIIC T130°C Ga/Db Zone 0/1, Zone 21 -40 °C ≤ Ta ≤ 75 °C	Ex db IIC T4 Ga/Gb Ex tb IIIC T130°C Ga/Db Zone 0/1, Zone 21 -40 °C ≤ Ta ≤ 75 °C	Ex db IIC T4 Ga/Gb Ex tb IIIC T130°C Ga/Db Zone 0/1, Zone 21 -40 °C ≤ Ta ≤ 75 °C	No hazardous area approval
NEC (USA)	—	—	Explosionproof Class I Div. 1 Groups A, B, C, D T4 Class II/III Div. 1 Groups E, F, G T130°C -40 °C ≤ Ta ≤ 75 °C Flameproof Class I Zone 0/1 AEx d IIC T4 Class II/III Zone 21 AEx tb IIIC T130°C -40 °C ≤ Ta ≤ 75 °C	No hazardous area approval
CEC (Canada)	—	—	Explosionproof Class I Div. 1 Groups B, C, D T4 Class II/III Div. 1 Groups E, F, G T130°C -40 °C ≤ Ta ≤ 75 °C Flameproof Class I Zone 0/1 Ex d IIC T4 Ga/Gb Class II/III Zone 21 Ex tb IIIC T130°C Db -40 °C ≤ Ta ≤ 75 °C	No hazardous area approval
EAC Ex (Russian market)	Ga/Gb Ex db eb IIC T4 X Da/Db Ex tb IIIC T130°C X Zone 0/1, Zone 21 -40 °C ≤ Ta ≤ 75 °C	Ga/Gb Ex db IIC T4 X Da/Db Ex tb IIIC T130°C X Zone 0/1, Zone 21 -40 °C ≤ Ta ≤ 75 °C	Ga/Gb Ex db IIC T4 X Da/Db Ex tb IIIC T130°C X Zone 0/1, Zone 21 -40 °C ≤ Ta ≤ 75 °C	No hazardous area approval
KCs (South Korea)	Ex d e IIC T4 Ex tb IIIC T130°C Zone 0/1; Zone 21 -40 °C ≤ Ta ≤ 75 °C	Ex d IIC T4 Ex tb IIIC T130°C Zone 0/1; Zone 21 -40 °C ≤ Ta ≤ 75 °C	Ex d IIC T4 Ex tb IIIC T130°C Zone 0/1; Zone 21 -40 °C ≤ Ta ≤ 75 °C	No hazardous area approval
Japanese approval	Ex d e IIC T4 Ga/Gb Ex t IIIC T130°C Db Zone 0/1, Zone 21 -40 °C ≤ Ta ≤ 75 °C	Ex d IIC T4 Ga/Gb Ex t IIIC T130°C Db Zone 0/1, Zone 21 -40 °C ≤ Ta ≤ 75 °C	Ex d IIC T4 Ga/Gb Ex t IIIC T130°C Db Zone 0/1, Zone 21 -40 °C ≤ Ta ≤ 75 °C	No hazardous area approval

Fig. 37: Certifications

9. Declaration of conformity

EU-Konformitätserklärung
EU-Konformitätserklärung
Déclaration UE de Conformité



MTS Sensor Technologie GmbH & Co. KG

EC17.001C

declares as manufacturer in sole responsibility that the position sensor type
erklärt als Hersteller in alleiniger Verantwortung, dass der Positionssensor Typ
déclare en qualité de fabricant sous sa seule responsabilité que les capteurs position de type

Temposonics® TH-x-xxxxx-xxx-x-D-N-N-Sxxxxxx-xxx
TH-x-xxxxx-xxx-x-G-N-N-Sxxxxxx-xxx
TH-x-xxxxx-xxx-x-E-N-N-Sxxxxxx-xxx

comply with the regulations of the following European Directives:
den Vorschriften folgender Europäischen Richtlinien entsprechen:
sont conformes aux prescriptions des directives européennes suivantes:

2014/30/EU	Electromagnetic Compatibility Elektromagnetische Verträglichkeit Compatibilité électromagnétique
2014/34/EU	Equipment and protective systems for use in potentially explosive atmospheres Geräte und Schutzsysteme zur Verwendung in explosionsgefährdeten Bereichen Appareils et systèmes de protection à être utilisés en atmosphères explosibles
2011/65/EU	Restriction of the use of hazardous substances in electrical and electronic equipment Beschränkung der Verwendung gefährlicher Stoffe in Elektro- und Elektronikgeräten Limitation de l'utilisation de substances dangereuses dans les équipements électriques et électroniques

Applied harmonized standards / Angewandte harmonisierte Normen / Normes harmonisées appliquées:

EN 60079-0 :2012+A11 :2013, EN 60079-1 :2014, EN 60079-7 :2015+A1 :2018, EN 60079-26 :2015, EN 60079-31 :2014
EN 61000-6-2 :2005, EN 61000-6-3 :2007+A1+AC :2012, EN 50581:2012

EC type examination certificate: **CML 16 ATEX 1090X Issue 1**

EG-Baumusterprüfbescheinigung:

Certificat de l'examen CE:

Issued by / ausgestellt durch / exposé par:

CML B.V.
Hoogoorddreef 15, 1101BA, Amsterdam, The Netherlands

Notified body for quality assurance control:

Benannte Stelle für Qualitätsüberwachung:

Organisme notifié pour l'assurance qualité:

CML B.V.
Hoogoorddreef 15, 1101BA, Amsterdam, The Netherlands

Ident number / Kennnummer /

No. d'identification:

2776

Kennzeichnung / Marking / Marquage:

Luedenscheid, 2019-03-17

Dr.-Ing. Eugen Davidoff
Zulassungsmanager / Approvals Manager



EU-Konformitätserklärung
EU-Konformitätserklärung
Déclaration UE de Conformité



MTS Sensor Technologie GmbH & Co. KG

EC16.015E

declares as manufacturer in sole responsibility that the position sensor type
erklärt als Hersteller in alleiniger Verantwortung, dass der Positionssensor Typ
déclare en qualité de fabricant sous sa seule responsabilité que les capteurs position de type

Temposonics® TH-x-xxxxx-xxx-1-N-N-N-Cxxxxxx-xxx
TH-x-xxxxx-xxx-x-N-N-N-Sxxxxxx-xxx

C = output type CANbasic / CANopen
S = output type SSI

comply with the regulations of the following European Directives:
den Vorschriften folgender Europäischen Richtlinien entsprechen:
sont conformes aux prescriptions des directives européennes suivantes:

2014/30/EU	Electromagnetic Compatibility Elektromagnetische Verträglichkeit Compatibilité électromagnétique
2011/65/EU	Restriction of the use of hazardous substances in electrical and electronic equipment Beschränkung der Verwendung gefährlicher Stoffe in Elektro- und Elektronikgeräten Limitation de l'utilisation de substances dangereuses dans les équipements électriques et électroniques

Applied harmonized standards / Angewandte harmonisierte Normen / Normes harmonisées appliquées:

EN 61000-6-2 :2005, EN 61000-6-3 :2007+A1+AC :2012
EN 50581 :2012

Luedenscheid, 2019-03-17

Dr.-Ing. Eugen Davidoff
Zulassungsmanager / Approvals Manager



10. Appendix

Safety Declaration

Dear Customer,

If you return one or several sensors for checking or repair, we need you to sign a safety declaration. The purpose of this declaration is to ensure that the returned items do not contain residues of harmful substances and / or that people handling these items will not be in danger.

MTS Sensors order number: _____ Sensor type(s): _____

Serial number(s): _____ Sensor length(s): _____

The sensor has been in contact with the following materials:

Do not specify chemical formulas.
Please include safety data sheets of the substances, if applicable.

In the event of suspected penetration of substances into the sensor, consult MTS Sensors to determine measures to be taken before shipment.

Short description of malfunction:

Corporate information

Company: _____

Address: _____

Contact partner

Name: _____

Phone: _____

E-mail: _____

We hereby certify that the measuring equipment has been cleaned and neutralized.
Equipment handling is safe. Personnel exposure to health risks during transport and repair is excluded.

Stamp

Signature

Date

GERMANY
MTS Sensor Technologie GmbH & Co.KG
Auf dem Schüffel 9
58513 Lüdenscheid, Germany
Tel. +49-23 51-95 87 0
Fax. +49-23 51-5 64 91
info.de@mtssensors.com
www.mtssensors.com

USA
MTS Systems Corporation Sensors Division
3001 Sheldon Drive
Cary, N.C. 27513, USA
Tel. +1 919 677-0100
Fax +1 919 677-0200
info.us@mtssensors.com
www.mtssensors.com



Sensor with Ex approval

UNITED STATES 3001 Sheldon Drive
MTS Systems Corporation Cary, N.C. 27513
Sensors Division Phone: +1 919 677-0100
Americas & APAC Region E-mail: info.us@mtssensors.com

GERMANY Auf dem Schüffel 9
MTS Sensor Technologie 58513 Lüdenscheid
GmbH & Co. KG Phone: +49 2351 9587-0
EMEA Region & India E-mail: info.de@mtssensors.com

ITALY Phone: +39 030 988 3819
Branch Office E-mail: info.it@mtssensors.com

FRANCE Phone: +33 1 58 4390-28
Branch Office E-mail: info.fr@mtssensors.com

UK Phone: +44 79 44 15 03 00
Branch Office E-mail: info.uk@mtssensors.com

SCANDINAVIA Phone: + 46 70 29 91 281
Branch Office E-mail: info.sca@mtssensors.com

CHINA Phone: +86 21 2415 1000 / 2415 1001
Branch Office E-mail: info.cn@mtssensors.com

JAPAN Phone: +81 3 6416 1063
Branch Office E-mail: info.jp@mtssensors.com

Document Part Number:

551902 Revision C (EN) 03/2020

