

Temposonics®

Magnetostrictive Linear Position Sensors

Connector system M12 for Sensor E-Series Embedded Technical Bulletin

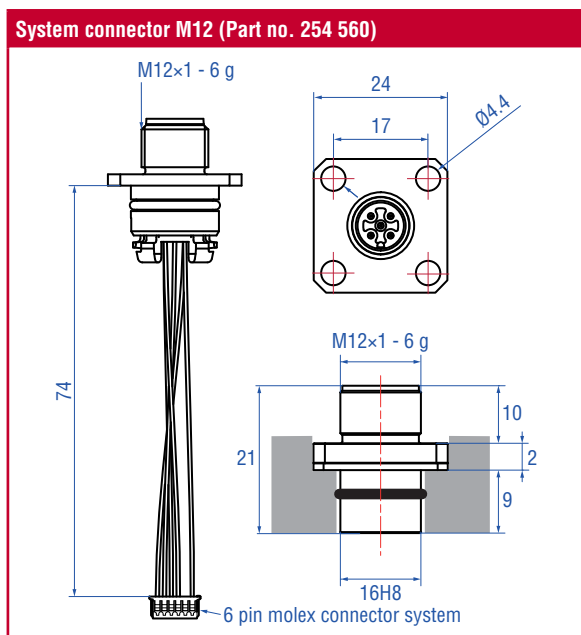

Installation Note:

The 6 pin molex connector of the system connector is plugged in the 6 pin molex connector of the sensor E-Series Embedded.

Insert the connector into the flange plate and click it in position. Note the nose of the connector and one of the two apertures of the flange, since the connector can be inserted also at an angle of 45 °.



1. Contact support for snapping into 2 staggered positions, at an angle of 45 ° to the flange plate
2. Flange plate in 4 positions staggered by 90 ° for screw mounting

Apply lubricant for O-rings and press the flange plate into the borehole. Fasten the flange plate using screws or rivets according to the list given below. The dimensions of screws for mounting the flange plate should be selected so that they do not collide with the lock nuts of the connected mating plugs.

PIN assignment analog 5 pin

4	5	3	Pin 1	+24 VDC (-15 / 20 %)
1	2		Pin 2	Signal
			Pin 3	DC Ground (0 V)
			Pin 4	n.c.
			Pin 5	DC Ground

Recommended M4 cylinder head screws with pan head, maximum diameter 7 mm:

- Hexagon socket head cap screw to DIN 912
- Hexalobular socket cylinder head screw to ISO 14580
- Slotted screw to DIN 84
- Comparable cross-head screw
- Comparable thread-forming screws

Screws should be inserted using resolvable safety adhesive. Alternatively, mounting can be done using a round head rivet to DIN 660.

With a corresponding mating plug the connector system fulfills IP rating IP69K.