



T e m p o s o n i c s ®

*P o s i t i o n S e n s o r s a n d S y s t e m s*

T e m p o s o n i c s ® I I  
P o s i t i o n S e n s o r s

*Installation & Instruction  
Manual for Analog Systems*

11-98 550032 Revision F

## **GENERAL INFORMATION**

---

### **MTS PHONE NUMBERS**

Application questions: 800-633-7609  
Repair Service: 800-248-0532  
Fax: 919-677-0200

### **SHIPPING ADDRESS**

MTS Systems Corporation  
Sensors Division  
3001 Sheldon Drive  
Cary, North Carolina 27513

### **HOURS**

*Monday - Thursday*

7:30 a.m. to 6:30 p.m. EST/EDT

*Friday*

7:30 a.m. to 5:00 p.m. EST/EDT

## TABLE OF CONTENTS

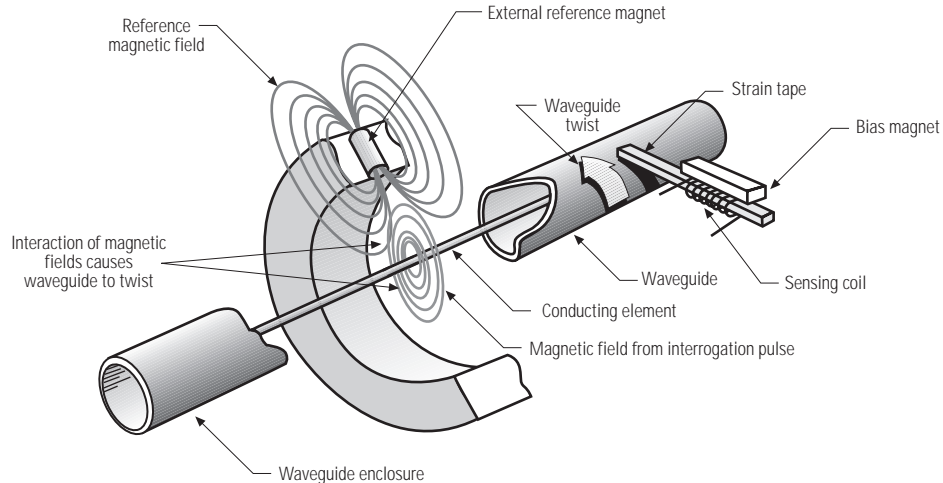
<i>Section</i>	<i>Page</i>
<b>1 INTRODUCTION</b>	<b>1</b>
1.1 Theory of Operation/Magnetostriction	1
1.2 Temposonics II LDT Specifications for Sensors <180 Inches	2
1.3 Temposonics II LDT Specifications for Sensors $\geq$ 180 inches	2
<b>2 TEMPOSONICS II LDT INSTALLATION</b>	<b>3</b>
2.1 Types of Transducer Supports	5
2.1.1 Loop Supports	5
2.1.2 Channel Supports	6
2.1.3 Guide Pipe Supports	6
2.2 Open Magnets	7
2.3 Spring Loading and Tensioning	7
2.4 Cylinder Installation	7
2.5 Installing Magnets	10
<b>3 TEMPOSONICS II WIRING</b>	<b>11</b>
<b>4 TROUBLESHOOTING THE LINEAR DISPLACEMENT TRANSDUCER</b>	<b>12</b>
<b>5 GROUNDING</b>	<b>13</b>
<b>6 INTRODUCTION TO ANALOG SYSTEMS</b>	<b>14</b>
6.1 Specifications of Analog System Components	15
6.1a Analog Personality Module (APM)	15
6.1b Analog Output Module (AOM) and Analog Output Card	15
<b>7 ANALOG PERSONALITY MODULE</b>	<b>16</b>
7.1 Performance Modes	16
7.2 APM Programming Procedure	18
<b>8 INSTALLING THE ANALOG OUTPUT MODULE (AOM)</b>	<b>21</b>
<b>9 ANALOG OUTPUT MODULE ADJUSTMENTS</b>	<b>22</b>
9.1 Nominal Range of Adjustments	22
9.2 Null and Full-Scale Adjustments	23
9.3 Velocity Null Adjustments	24
<b>10 ANALOG OUTPUT MODULE/WIRING PROCEDURES</b>	<b>25</b>
10.1 Preparing Cable for Connection to the AOM	25
10.2 J1 Installation Wiring	26
10.3 J1 Connections for AOM	27
10.4 J1 Connection to AOM with MS Connectors	29
10.5 J1 Connections	29
<b>11 TROUBLESHOOTING THE ANALOG OUTPUT MODULE</b>	<b>32</b>
11.1 General	32
11.2 Power Supply Check	32
11.3 Grounding	33
11.4 Connections	33
11.5 LDT Signals	33
<b>12 ANALOG OUTPUT CARD</b>	<b>36</b>

# 1. Introduction to the Temposonics II Linear Displacement Transducer (LDT)

The Temposonics II LDT precisely senses the position of an external magnet to measure displacement with a high degree of accuracy and resolution. Using the principle of magnetostriction (see Section 1.1, below), the Temposonics II LDT measures the time interval between the initiation of an interrogation pulse and the detection of a return pulse. A variety of interface devices use the data derived from these two pulses and generates an analog or digital output to represent position.

## 1.1 Theory of Operation/Magnetostriction

The interrogation pulse travels the length of the transducer by a conducting wire threaded through a hollow waveguide. The waveguide is spring loaded within the transducer rod and exhibits the physical property of magnetostriction. When the magnetic field of the interrogation pulse interacts with the stationary magnetic field of the external magnet, a torsional strain pulse or "twist" is produced in the waveguide. This strain pulse travels in both directions, away from the magnet. At the end of the rod, the strain pulse is damped within the "dead zone". At the head of the transducer, two magnetically coupled sensing coils are attached to strain sensitive tapes. The tapes translate the strain pulse through coils to an electrical "return pulse". The coil voltage is then amplified in the head electronics before it is sent to various measuring devices as the conditioned "return pulse".



**Figure 1-1**  
**Waveguide Interaction**

## 1.2 Temposonics II LDT Specifications for Sensors <180 Inches

<b>Parameter</b>	<b>Specifications</b>
Input Voltage:	± 12 to ± 15 Vdc
Current Draw:	<b>Transducer Only:</b> ± 15 Vdc at 100 mA maximum, 25 mA minimum (current draw varies with magnet position, maximum draw occurs when magnet is at 2 in. (50.6 mm) from the flange and minimum update time is being utilized) <b>Transducer with:</b> <ul style="list-style-type: none"> <li>• <i>Analog Personality Module (APM):</i>                ± 13.5 Vdc to ±15 Vdc at 190 mA maximum, 115 mA minimum</li> <li>• <i>Analog Output Module (AOM):</i>                + 15 Vdc at 250 mA, -15 Vdc at 65 mA</li> </ul>
Displacement:	Up to 25 feet (7620 millimeters)
Dead Zone:	2.5 inches (63.5 millimeters) for stroke lengths up to 179.9 in.
Electronics Enclosure:	IP-67
Non-linearity:	< ± 0.05% of full scale or ± 0.002 inch (±0.05 mm), whichever is greater
Resolution:	1 ÷ [gradient x crystal freq. (mHz) x circulation]; maximum resolution: 0.006 mm or 0.00025 in.
Repeatability:	Equals resolution
Hysteresis:	0.0008 inch (0.02 mm) maximum
Update Time:	Resolution and Stroke dependent Minimum = [Stroke (specified in inches) + 3] x 9.1 µs
Operating Temperature	
Head Electronics:	- 40 to 150°F (- 40 to 66°C)
Transducer Rod:	- 40 to 185°F (- 40 to 85°C)
Operating Pressure:	3000 psi continuous, 8000 psi static
Analog Outputs (absolute)	Standard 0 to10 Vdc (other voltage outputs are available) Optional: 4-20 mA (AOM)

*Specifications are subject to change without notice. Consult MTS for verification of specifications critical to your application.*

## 1.3 Temposonics II LDT Specifications for Sensors ≥180 Inches

Below is a list of specifications that pertain to Temposonics II transducers with active stroke lengths of 180 inches (5083 mm) to 300 inches (7620 mm). The below specifications apply only to sensors 180 to 300 inches in length. Specifications not listed below may be found in section 1.2, above.

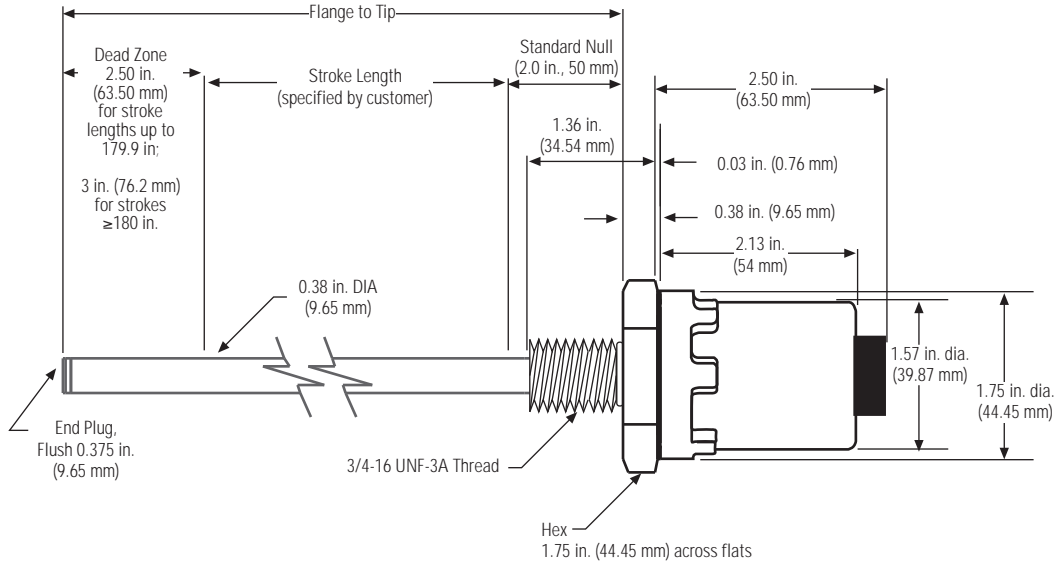
<b>Parameter</b>	<b>Specifications</b>
Input Voltage:	<ul style="list-style-type: none"> <li>• Maximum: ± 15 Vdc, ± 5% at 100 mA</li> <li>• Minimum: ± 15 Vdc at 25 mA</li> </ul> (current draw varies with magnet position, maximum draw occurs when magnet is 2 inches (50.8 mm) from the flange and minimum update time is being used)
Dead Zone:	3 in. (76.2 mm)
Cable Length:	<ul style="list-style-type: none"> <li>• Maximum cable length for neuter version transducer (i.e., Temposonics II without an integrated Personality Module) which requires the use of external interface electronics (Analog Output Module, Digital Interface Box or other signal conditioners) is 250 ft.</li> <li>• APM: 150 ft.</li> <li>• AOM: 250 ft.</li> </ul>
Magnet Requirement:	Part Numbers: 201554, 201553, 251416, 201542

*Specifications are subject to change without notice. Consult MTS for verification of specifications critical to your application.*

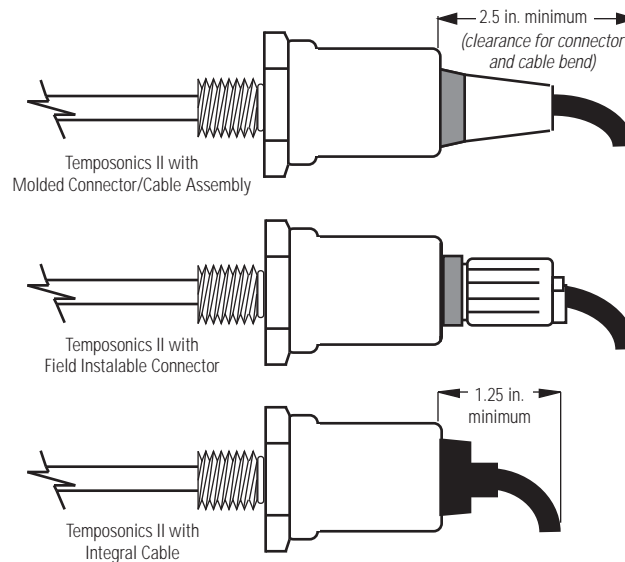
## 2. Temposonics II LDT Installation

Before beginning installation, be sure you know the following dimensions (as illustrated in Figures 2-1 to 2-3a-c.):

- Null Space
- Stroke
- Dead Zone

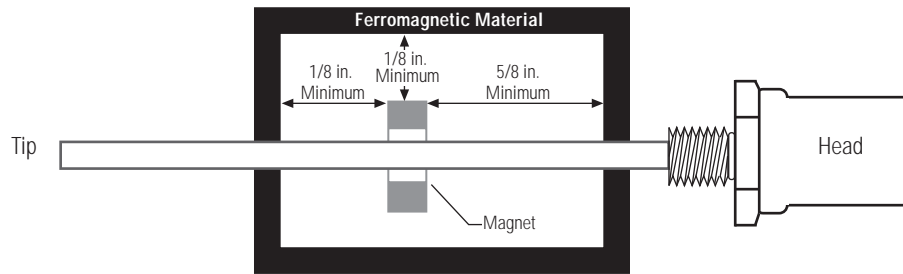


**Figure 2-1**  
**Temposonics II Dimensions**

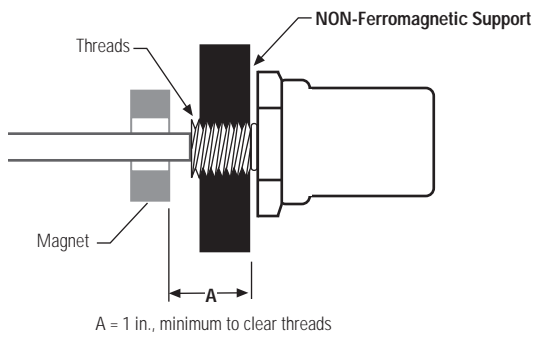


**Figure 2-2**  
**Temposonics II Connector/Cable Clearance Requirements**

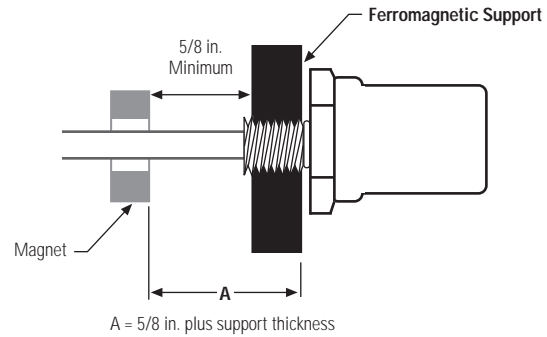
1. Use the 3/4 inch (19 mm), 16 UNF thread of the transducer to mount it at the selected location. Leave room to access the hex head. If a pressure or moisture seal is required, install an O-ring (type MS 28778-8 is recommended) in the special groove. Use the hex head to tighten the transducer assembly.
2. Install the permanent magnet over the LDT rod. Mount the permanent magnet to the movable device whose displacement will be measured. To minimize the effect of magnetic materials (i.e. iron, steel, etc.) on the magnetic field of the permanent magnet, ensure the minimum spacing requirements are met as shown in Figures 2-3a-c. (Any non-magnetic materials can be in direct contact with the permanent magnet without affecting performance.)



**Figure 2-3a**  
**Minimum Magnet Clearance Using Magnetic Supports**



**Figure 2-3b**  
**Minimum Null Space Using Non-Magnetic Support**



**Figure 2-3c**  
**Minimum Null Space Using Magnetic Support**

**NOTES:**

1. The magnet must not contact ferromagnetic materials (such as iron or steel). Clearances are required between the surface of the magnet and ferromagnetic material, as shown. Non-ferrous material (such as copper, brass, or 300 series stainless steel) may contact the magnet without affecting transducer performance.
2. Standard Null Space is 2 inches. There is no maximum limit for Null Space. Less than 2 inches can be specified if magnet clearances meet requirements illustrated above.

**NOTE:**

*Clearance between the magnet and the transducer rod is not critical. However, contact between the components will cause wear over time. The installation of supports or readjustment of the supports is recommended if the magnet contacts the transducer rod.*

3. Move the permanent magnet full-scale to check that it moves freely. If not (if the magnet rubs on the transducer) you can correct this by mounting a support bracket to the end of the transducer. Long transducers may need additional supports to be attached to the transducer rod. Transducer supports are described later in this section.

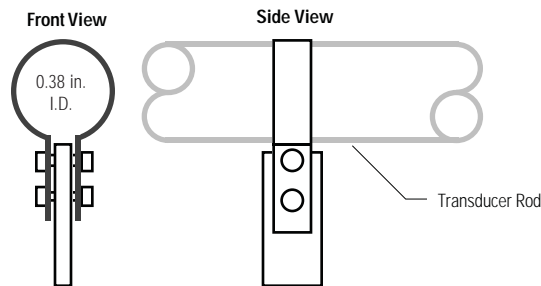
## **2.1 Types of Transducer Supports**

Long transducers (48 inches or longer) may require supports to maintain proper alignment between the transducer rod and the permanent magnet. When transducer rod supports are used, special, open-ended permanent magnets are required.

Transducer supports attached to the active stroke length must be made of a non-ferrous material, thin enough to permit the permanent magnet to pass without obstruction. Because the permanent magnet does not enter the dead zone, supports connected within the dead zone may be made of any material. The main types of supports are loop, channel, and guide pipe supports.

### **2.1.1 Loop Supports**

Loop supports are fabricated from non-ferrous materials, thin enough to permit free movement of the magnet. Loop supports are recommended for straight transducers and may be spaced apart approximately every three feet. They may be used alone or with channel supports. Figure 2-4 illustrates the fabrication of a loop support.



**Figure 2-4**  
**Loop Support**

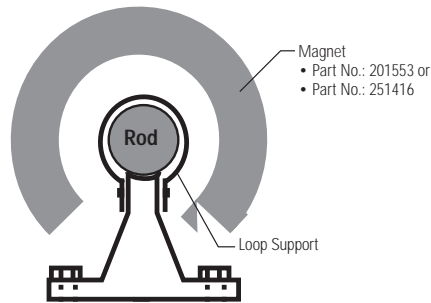
**NOTE:**

*When open magnets are used, ensure the transducer rod remains within the inside diameter of the magnet throughout the length of the stroke. If the transducer rod is allowed to enter the cut out area of an open magnet, the transducer signal could attenuate or be lost. See Figure 2-7.*



### 2.1.2 Channel Supports

Channel supports, being typically straight, are normally used with rigid transducers. A channel support consists of a straight channel with loop supports mounted at intervals. The loop supports are required to keep the transducer within the channel. Figure 2-5 shows a channel support. Channel supports are available from various manufacturers or may be fabricated.

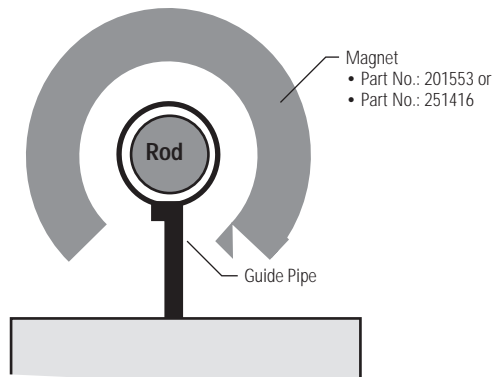


**Figure 2-5**  
**Channel Support**

### 2.1.3 Guide Pipe Supports

Guide pipe supports are normally used for flexible transducers. A guide pipe support is constructed of non-ferrous material, straight or bent to the desired shape. As shown in Figure 2-6, both inside and outside dimensions of the pipe are critical:

- Because the transducer rod is installed inside the pipe, the inside diameter of the pipe must be large enough to clear the rod.



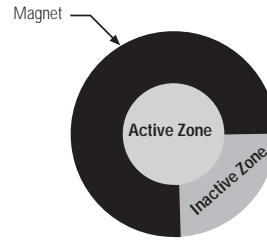
**Figure. 2-6**  
**Guide Pipe Support**

- The outside diameter of the pipe must be small enough to clear the magnet.

Refer to pipe manufacturers' specifications and dimensions (schedule 10, 40, etc.) to select the appropriate size pipe. Guide pipe is typically supported at each end of the pipe.

## 2.2 Open Magnets

When using an open magnet, make sure the rod is positioned at all times within the “active” zone of the magnet. The transducer cannot operate properly unless the entire stroke of the transducer rod is located within this zone. The active zone, as shown in Figure 2-7, lies within the inside diameter of the magnet.

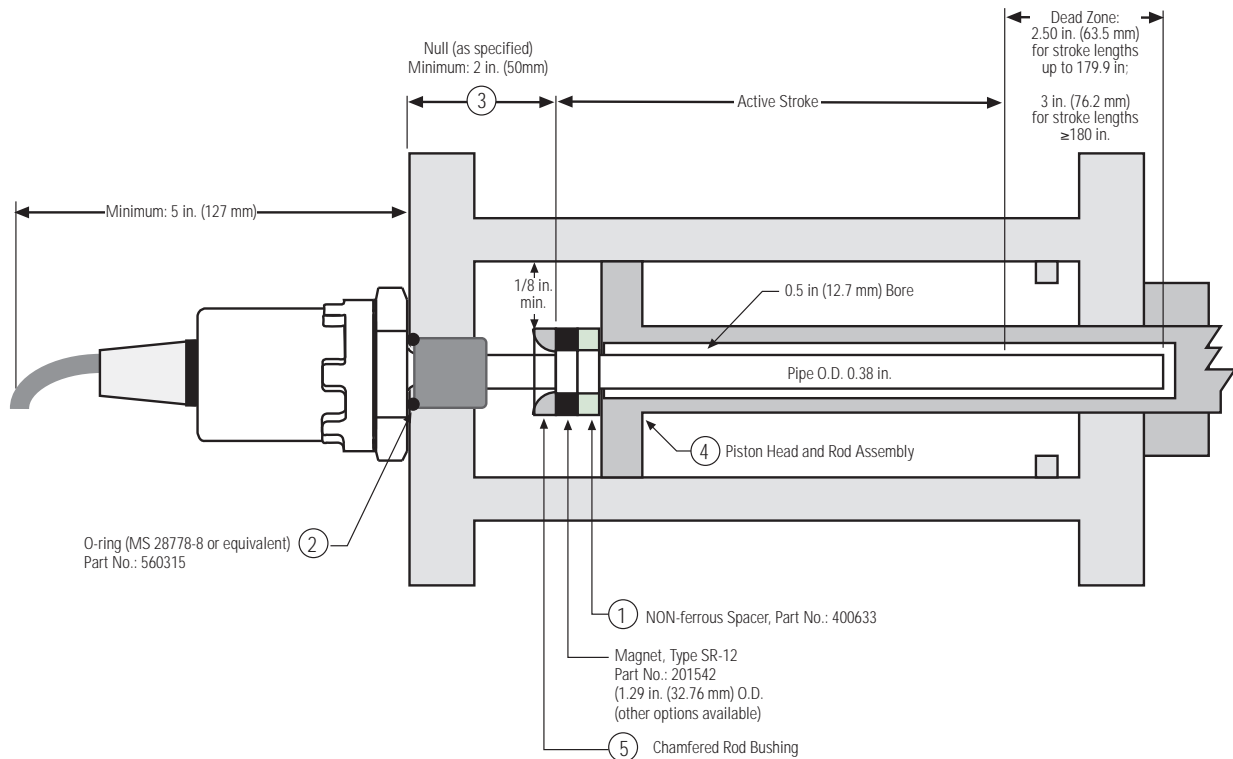


**Figure 2-7**  
**Active Zone for Open Magnets**

## 2.3 Spring Loading or Tensioning

The transducer rod can be spring loaded or tensioned using a stationary weight. Attach a spring mechanism or weight to the dead zone of the transducer rod with a clamping device which will not deform the transducer rod. The maximum weight or spring tension is 5 to 7 lbs.

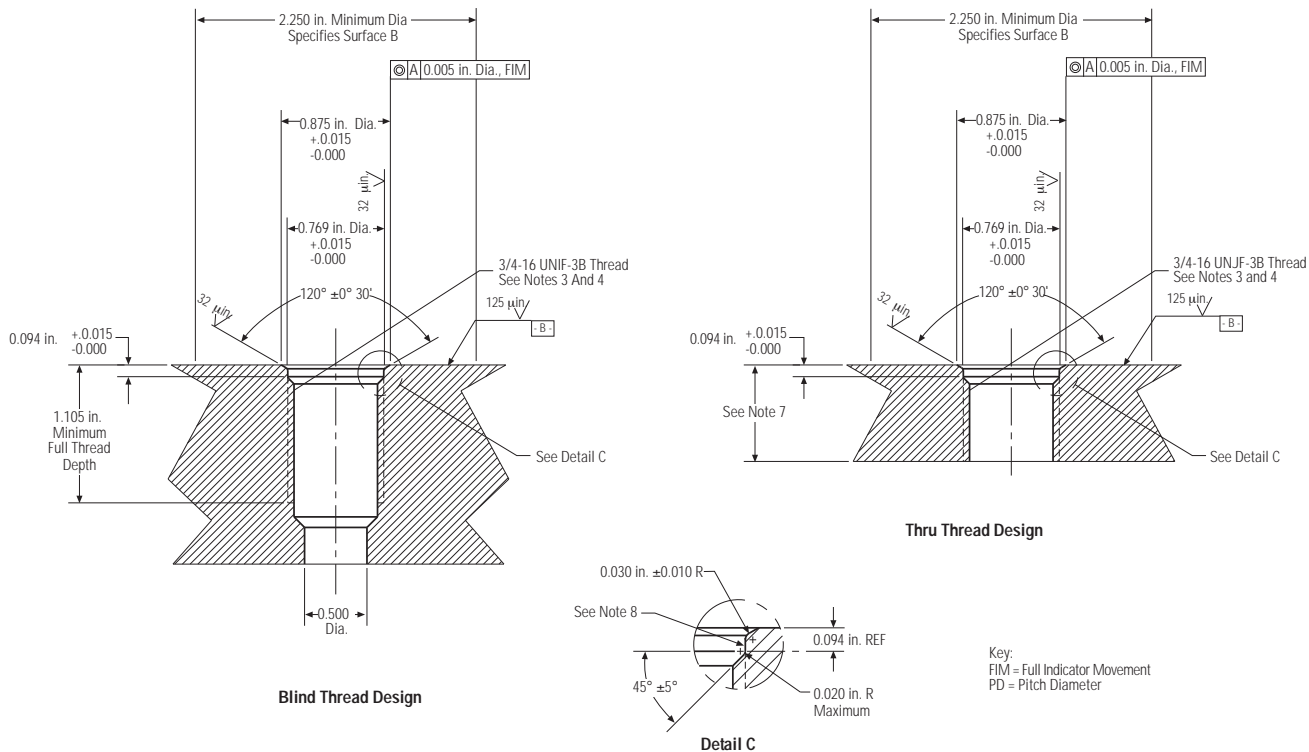
## 2.4 Cylinder Installation



**Figure 2-8**  
**Typical Cylinder Installation**

Figure 2-8 shows a typical cylinder installation. Review the following before attempting this type of installation.

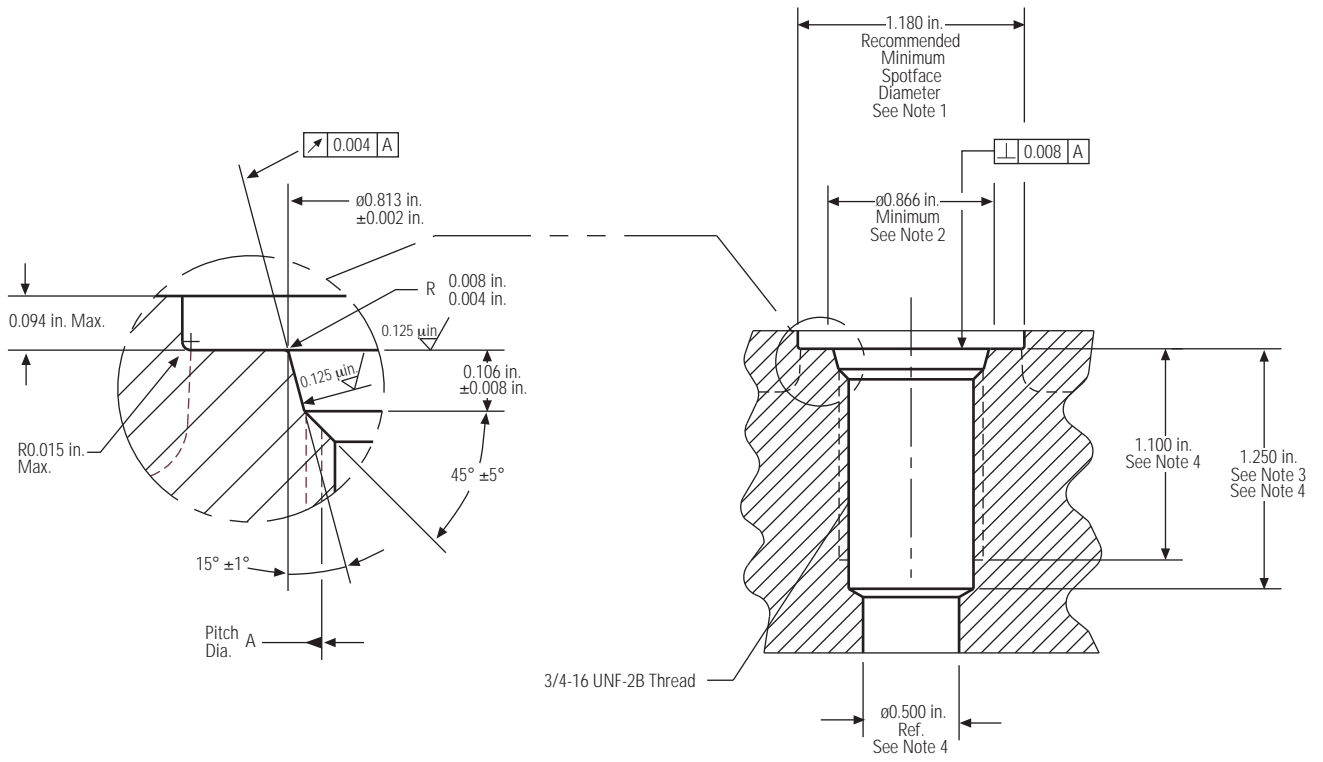
- Use a non-ferrous (plastic, brass, Teflon®, etc.) spacer [1] to provide 1/8 inch (32 mm) minimum space between the magnet and the piston.
- An O-ring groove [2] is provided at the base of the transducer hex head for pressure sealing. MTS uses mil-standard MS33514 for the O-ring groove. Refer to mil-standard MS33649 or SAE J514 for machining of mating surfaces.
- The null space [3] is specified according to the installation design and cylinder dimensions. The analog output module provides a null adjustment. Make sure that the magnet can be mounted at the proper null position.
- The piston head [4] shown in Figure 2-8 is typical. For some installations, depending on the clearances, it may be desired to countersink the magnet.
- A chamfered rod bushing [5] should be considered for strokes over 5 feet (1.5 meters) to prevent wear on the magnet as the piston retracts. The bushing should be made from Teflon or similar material.
- The recommended bore for the cylinder rod is 1/2 inch (13 mm). The transducer rod includes a 0.375 inch (9.53 mm) diameter end plug mounted flush. Use standard industry practices for machining and mounting of all components. Consult the cylinder manufacturer for applicable SAE or military specifications.



NOTES:

1. Dimensions and tolerances based on ANSI Y14.5-1982.
2. MTS has extracted all pertinent information from MS33649 to Generate this document.
3. PD must be square with surface B within 0.005 FIM across 2.250 dia minimum.
4. PD must be concentric with 2.250 dia within 0.030 FIM and with 0.769 dia within 0.005 FIM.
5. Surface texture ANSI B46.1-1978
6. Use o-ring MTS part number 560315 for correct sealing.
7. The thru thread design shall have sufficient threads to meet strength requirements of material used.
8. Finish counter-bore shall be free from longitudinal and spiral tool marks. Annular tool marks up to 32 micro-inches maximum will be permissible.

**Figure 2-9**  
**O-ring Boss Detail**



**NOTES:**

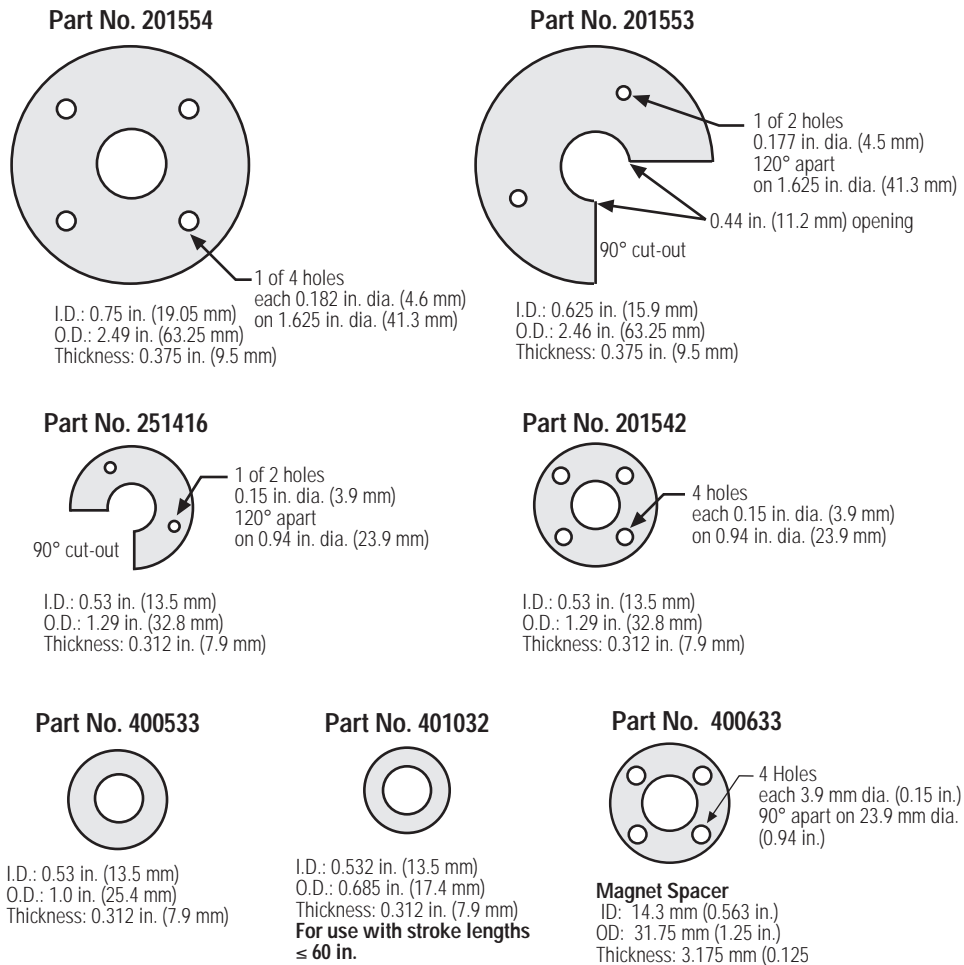
1. If face of port is on a machined surface, dimensions 1.180 and 0.094 need not apply as long as R0.008/0.004 is maintained to avoid damage to the O-ring during installation.
2. Measure perpendicularity to A at this diameter.
3. This dimension applies when tap drill cannot pass through entire boss.
4. This dimension does not conform to SAE J1926/1.

**Figure 2-10**  
**Port Detail (SAE J1926/1)**

## 2.5 Installing Magnets

Figure 2-11 below shows the standard magnet types and dimensions. The circular magnet with an outside diameter of 1.29 inches and 0.53 inch inside diameter (Part No. 201542) is the most common and is suitable for most applications. Larger magnets, with an outside diameter of 2.5 inches are typically only used with Temposonics transducers that exceed 180 inches in stroke length. Magnets with a 90 degree cut-out are used in applications that require intermediate supports along the transducer rod.

If upon installation, the null adjustment is inadequate, you can design a coupler with adjustments to mount the magnet to the measured member.



**Figure 2-11**  
**Magnet Dimensions**

### 3. Temposonics II Wiring

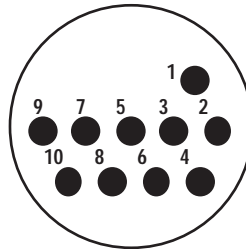
Table 3A

Temposonics II Connections (Neuter Version and with APM)

Pin No.	Temposonics II Integrated or Extension Cable (see Note 1)		Temposonics II Configurations:	
	Wire Color Code	Wire Color Code	Neuter	APM Option
1	White/Blue Stripe	White	DC Ground	DC Ground
2	Blue/White Stripe	Brown	Frame	Frame
3	White/Orange Stripe	Gray	Not Used	Displacement Return
4	Orange/White Stripe	Pink	Not Used	Displacement Out
5	White/Green Stripe	Red	+Vdc	+Vdc
6	Green/White Stripe	Blue	-Vdc	-Vdc
7	White/Brown Stripe	Black	Output Pulse Return	Not Used
8	Brown/White Stripe	Violet	Output Pulse	Not Used
9	White/Gray Stripe	Yellow	(+) Interrogation (Notes 2, 3)	Not Used
10	Gray/White Stripe	Green	(-) Interrogation (Notes 2, 3)	Not Used

**NOTES:**

1. Verify if the cable has striped or solid color leads and make connections accordingly.
2. 1 to 4 microseconds maximum pulse duration.
3. **WARNING:** Under no condition should both the positive (+) and negative (-) interrogation leads be connected at the same time when using the "NEUTER" version Temposonics II transducer. The unused interrogation lead must be connected to DC ground.
4. Temposonics II w/APM requires +/-13.5 to +/-15 Vdc. All others require +/-12 Vdc to +/-15 Vdc.



**Temposonics II 10-Pin Connector**  
(connections styles RB or RC)

Table 3B

Connections - Original Temposonics Transducer

Original Temposonics Connector Pin Number	Wire Color Code	Signal Function
A	Green or Gray	+ 15 Vdc
B	Black	DC Ground
C	Orange or Brown	Return Pulse (from LDT)
D	Blue	- 15 Vdc
E	White	Interrogation Pulse
F	Red	+ 12 Vdc

## 4. Troubleshooting the Linear Displacement Transducer

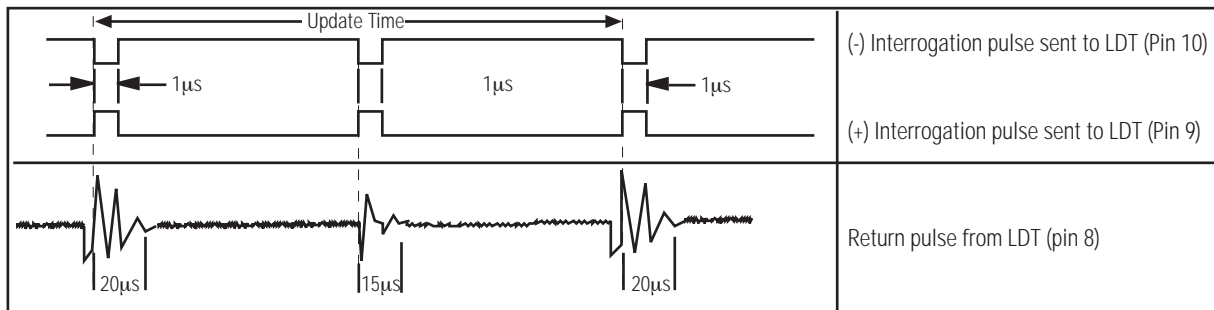
**NOTE:**

*The following checklist is for general diagnostic purposes. Purchase of replacement components should not be based solely on this checklist. Consult MTS Sensors Division for recommendations and factory service before ordering replacement components.*

Use the below checklist when operational problems are encountered. The possible causes of faulty output are listed below in order of probability of occurrence, and should be checked in order.

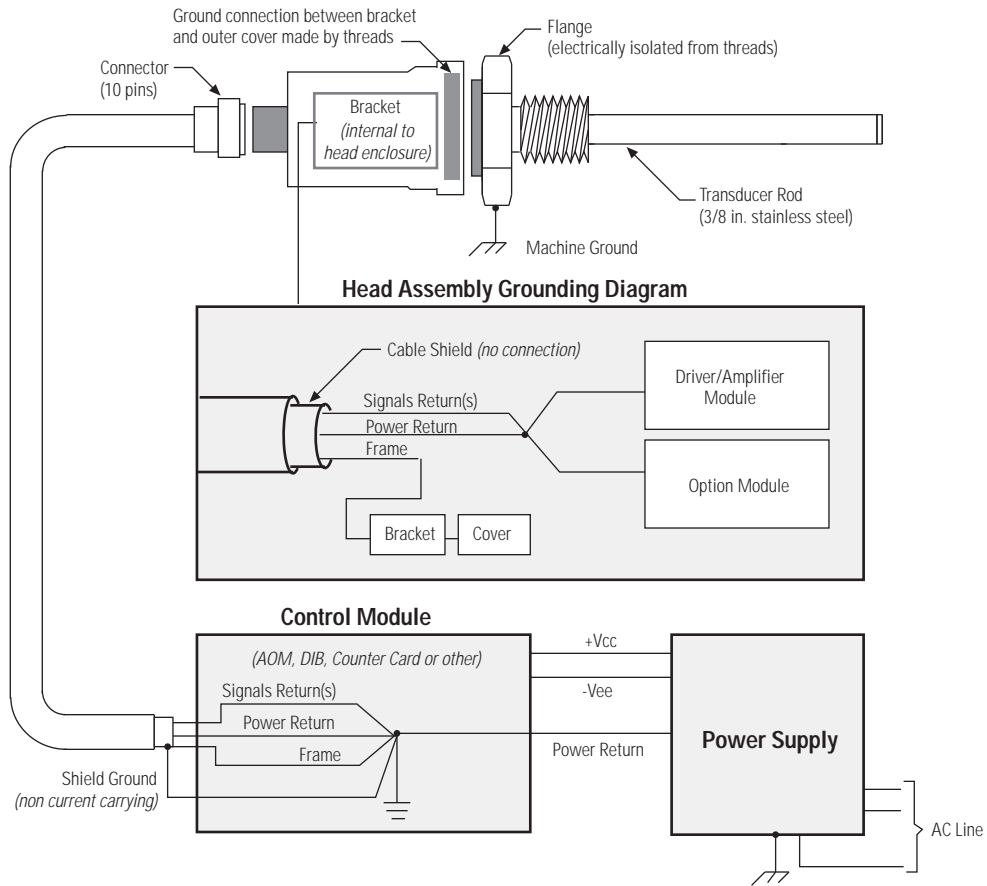
1. Improper power supply/power connection
2. Mismatched system components\*
3. Ground loops/improper grounding\*
4. Improper wiring
5. Incorrect receiver device or software\*
6. Improper magnet mounting
7. EMI noise, affecting transducer or transducer cable
8. Circuit fault within transducer

\* Will cause erratic or unstable output

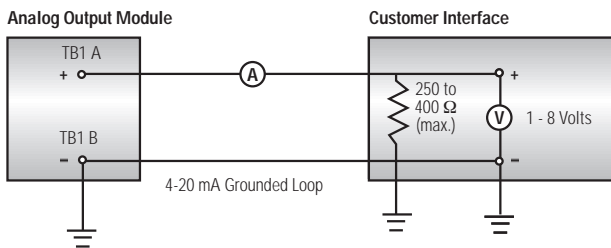


**Figure 4-1**  
**Temposonics II Transducer Signals**

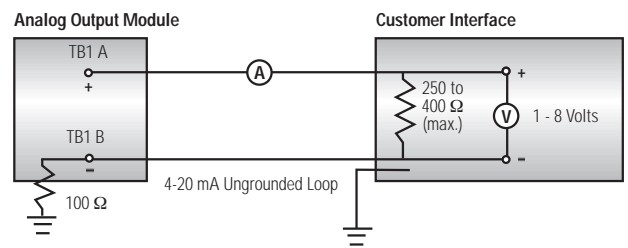
## 5. Grounding



**Figure 5-1**  
**Grounding**



**Figure 5-2**  
**4-20mA Grounded Loop**



**Figure 5-3**  
**4-20mA Ungrounded Loop**

**NOTES FOR FIGURES 5-2 & 5-3:**

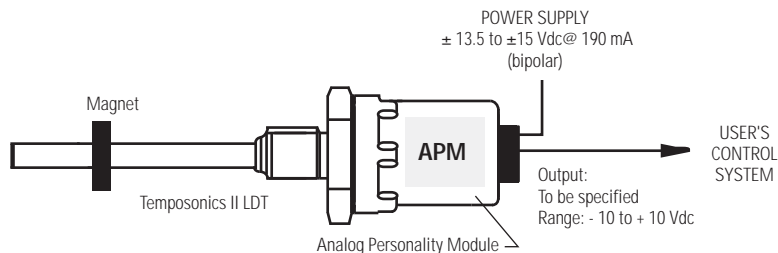
1. Selecting the grounding scheme is dependent upon the controller interface.
2. The current loop path must be completed for the system to operate.
3. The ungrounded loop is not truly isolated from ground. Isolators are required if this configuration is needed by the controller interface.



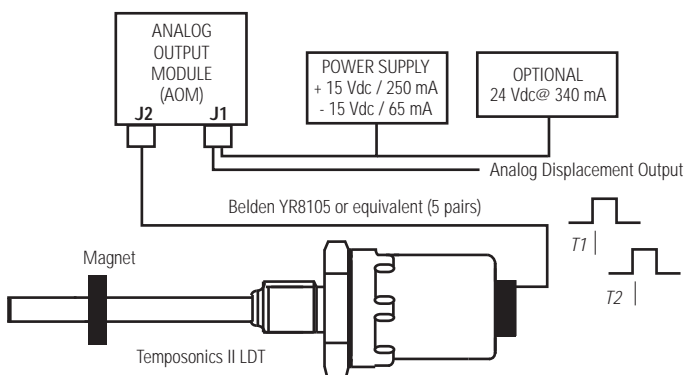
## 6. Introduction to Analog Systems

Temposonics II Analog Systems include a Linear Displacement Transducer (LDT), a magnet, and an Analog Personality Module (APM), Analog Output Module (AOM), or an Analog Output Card. See Figures 6-1, 6-2 and 6-3. The APM, AOM and Analog Output Card generate the interrogation pulse, sense the return pulse, and develop the analog output displacement signal (voltage or current).

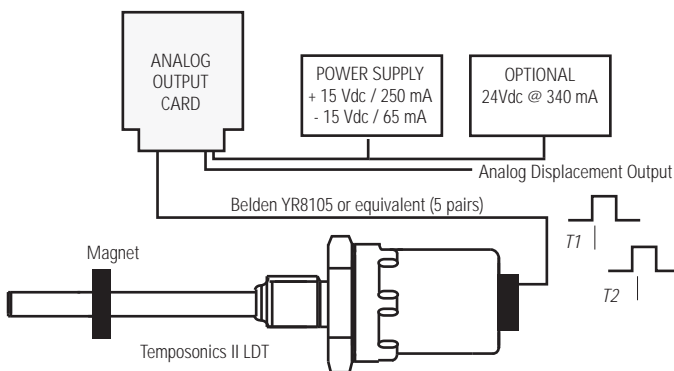
The Analog Personality Module (Figure 6-1) is installed in the electronics enclosure of the Temposonics II transducer. The Analog Output Module and Analog Output Card are both separate interface devices.



**Figure 6-1**  
**Analog System Configuration with Analog Personality Module**



**Figure 6-2**  
**Analog System Configuration with Analog Output Module (AOM)**



**Figure 6-3**  
**Analog System Configuration with Analog Output Card**

## 6.1 Specifications of Analog System Components

### 6.1a Analog Personality Module (APM)

<i>Parameter</i>	<i>Specification</i>
Power Requirements:	$\pm 13.5$ Vdc to $\pm 15$ Vdc at 190 mA maximum, 115 mA minimum
Output Impedance:	10 K $\Omega$ minimum load for voltage output
Output:	Specified by user; Range: - 10 Vdc to + 10 Vdc, forward or reverse acting
Temperature Requirements:	
<i>Storage:</i>	- 40 to 150°F (- 40 to 70°C)
<i>Operating:</i>	- 32 to 150°F (-30 to 70°C)
<i>Coefficient:</i>	10 ppm/°F (18 ppm °C)
Maximum Cable Length:	150 ft.
Standard Features:	Field programmable

*Specifications are subject to change without notice. Consult MTS for verification of specifications critical to your application.*

### 6.1b Analog Output Module (AOM) and Analog Output Card

<i>Parameter</i>	<i>Specification</i>
Power Requirements:	
<i>Standard:</i>	+ 15 Vdc ( $\pm 2\%$ ) at 250 mA, < 1% ripple - 15 Vdc ( $\pm 2\%$ ) at 65 mA, < 1% ripple
<i>Optional:</i>	+ 24 Vdc ( $\pm 2\%$ ) at 340 mA, < 1% ripple
Output Impedance:	5 K $\Omega$ minimum load for voltage output, 400 $\Omega$ maximum for 4-20 mA output
Velocity Output:	0 to $\pm 10$ Vdc at 1 to 400 in. per second Positive voltage output as magnet travels away from the transducer's head assembly, negative voltage output as the magnet travels toward the transducer's head assembly.
Temperature Requirements:	
<i>Storage:</i>	- 40 to 180°F (- 40 to 82°C)
<i>Operating:</i>	- 40 to 180°F (- 40 to 82°C)
<i>Coefficient:</i>	20 ppm/°F (36 ppm/°C)
Standard Features:	Non-volatile memory permanently stores set-up information. Surface mounted components reduce moment of inertia and enhance shock and vibration resistance of the module.

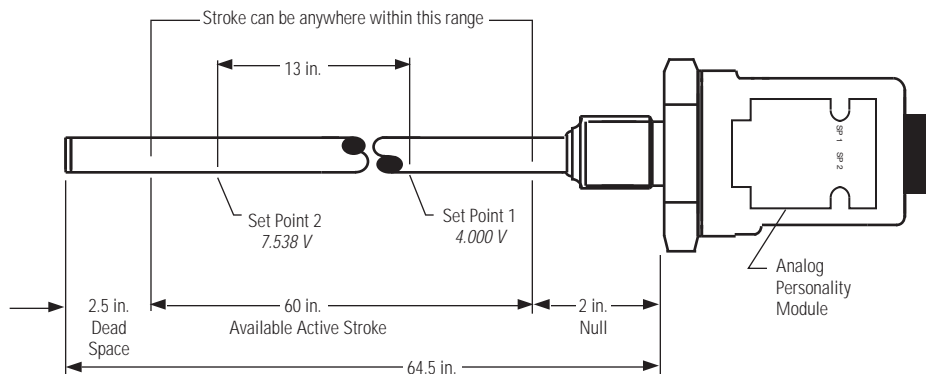
*Specifications are subject to change without notice. Consult MTS for verification of specifications critical to your application.*

## 7. Analog Personality Module

The Analog Personality Module (APM) is mounted inside the electronics housing of the Temposonics II linear displacement transducer and produces a direct analog output. No additional interfacing electronics are required. The APM processes digital data into an analog output via a digital to analog converter (DAC). MTS uses a 16-bit DAC to provide the best available resolution performance.

Typically the APM will be ordered with the Temposonics II transducer. The APM is installed, and the set points and output voltages are pre-set at the factory.

In the example below (Figure 7-1) we have a 60 inch stroke, note the indicated active stroke range. Set points cannot be set within the null or dead space area, they can only be set within the active stroke area. The 13 inch stroke selected in the example is defined by Set Point 1 (set at 4.000 volts) and Set Point 2 (set at 7.538 volts). Set Point voltage values can range from -10 to +10 Vdc.



**Figure 7-1**  
**Voltage & Displacement - 100% Scalable.**

### 7.1 Performance Modes

Update time (or response time) for analog systems is based upon the active stroke of the transducer and the resolution desired. To get the best mix of update time and resolution for your particular application, three modes are available with the APM. These modes are as follows:

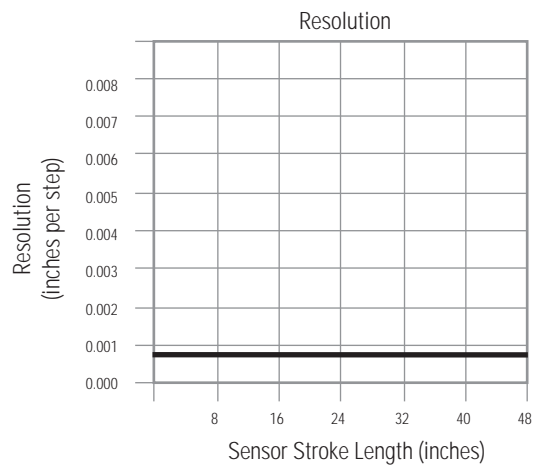
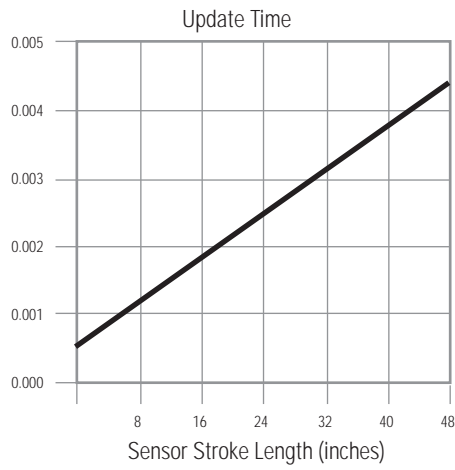
**Resolution-Preferred Mode** - In this mode the APM generates a high resolution output while sacrificing update time. The Resolution Preferred Mode is limited to stroke lengths up to 48 inches and will provide an output resolution of approximately 0.001 inches. In applications exceeding 48 inches, the APM must be set for Balanced Mode or Update Preferred Mode. In the programming procedure, the Resolution Preferred Mode is indicated by an output of 0 volts.

**Balanced Mode** - In this mode the APM offers a "balance" between update time and resolution. For stroke lengths up to 250 inches, the output resolution will be approximately 0.003 inches. In the programming procedure, this mode is indicated by an output of +8.4 volts.

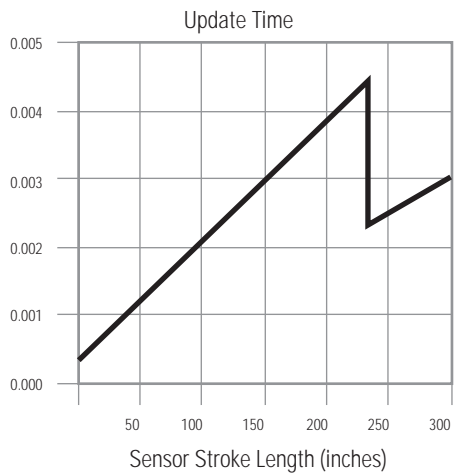
**Update Preferred Mode** - In this mode the APM produces the fastest possible update time while sacrificing resolution. For stroke lengths up to 300 inches, the output resolution will be approximately 0.007 inches. In the programming procedure, this mode is indicated by an output of -8.4 volts.

The mode desired is selected at the time of order and factory pre-set. The following charts identify the update time and resolution for each mode.

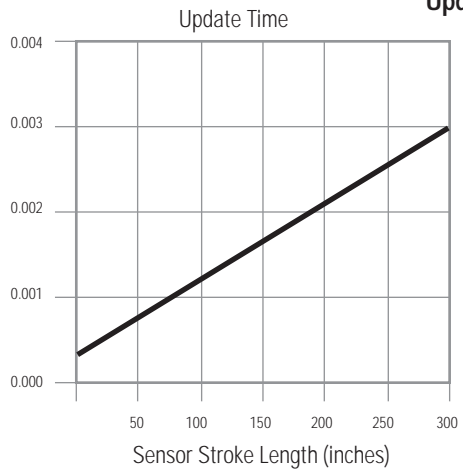
### Resolution Preferred Mode



### Balanced Mode



### Update Preferred Mode

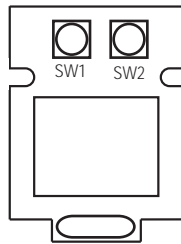


## 7.2 APM Programming Procedure

---

**! CAUTION !**

*If the APM is being programmed for the first time, the analog output at power-up will be near zero volts. The programming steps are the same in this case, but the analog output will return to zero volts until valid information is stored for both Set Point 1 and Set Point 2. When both Set Points have been programmed, the transducer will enter normal operating mode and produce an analog output scaled according to the information permanently stored in the APM's memory.*



**Figure 7-2**  
**APM, Top View**

**! CAUTION !**

*IMPORTANT: Before beginning the programming procedures, supply power to the APM for a full 5 minutes. This will allow all components to stabilize and ensure set point accuracy.*

The output range of the APM is determined by choosing two endpoints within the active stroke length of the transducer and using the two push-buttons to assign a voltage to each point. The two endpoints are called Set Point 1 (SW1) and Set Point 2 (SW2). Any voltage from -10 volts to +10 volts may be assigned to either point; the APM will automatically scale the output to the specified range. Set Point 1 must be the set point closest to the head electronics.

In addition, the APM can be programmed for one of three performance modes, as described earlier. During the programming procedure, each mode is represented by a particular output voltage. They are as follows:

**Resolution-Preferred Mode** - In the programming procedure, the Resolution Preferred Mode is indicated by an output of 0 volts.

**Balanced Mode** - In the programming procedure, this mode is indicated by an output of +8.4 volts.

**Update Preferred Mode** - In the programming procedure, this mode is indicated by an output of -8.4 volts.

The number of recirculations shown will also indicate which mode the APM is programmed, see Mode Table below.

**Mode Table**

Mode Select Voltages*	Recirculations
Resolution Mode = 0.0 V	8 recirculations
Balance Mode = + 8.4 V	2 recirculations
Update Mode = - 8.4 V	1 recirculation

\* Voltages are approximate values.

When programming the APM, use the table below as a reference.

**APM Programming Reference Guide**

Press	Approx. Output voltage	Function	Reference
SW1 (for 3 seconds)	+4.2 Vdc	Start program mode	Step 1
SW2	see mode table	Select mode	Step 2
SW1	-4.2 Vdc	Locks mode in	Step 3
SW1 (setpoint 1) or SW2 (setpoint 2)	-2.1 Vdc  +2.1 Vdc	Select setpoint 1 to program  Select setpoint 2 to program	Step 4  Step 10
SW1 or SW2 at setpoint 1 or 2	Desired output voltage voltage needed at setpoint 1	Select desired output	Step 5 or 11
SW1 and SW2	Setpoint voltage	Lock in program	Step 6 or 12

**NOTES:**

1. Always program setpoint 1 first, lock in program, then complete the steps to program setpoint 2.
2. When adjusting the output voltage (step 4) make sure the magnet is in the position of the setpoint.
3. Setpoint 1 will always be the setpoint closest to the transducer head.
4. If a mistake is made during programming, turn off power, wait a few seconds, turn power on and start over.

It is necessary to monitor the analog output with a digital voltmeter while performing the following steps.

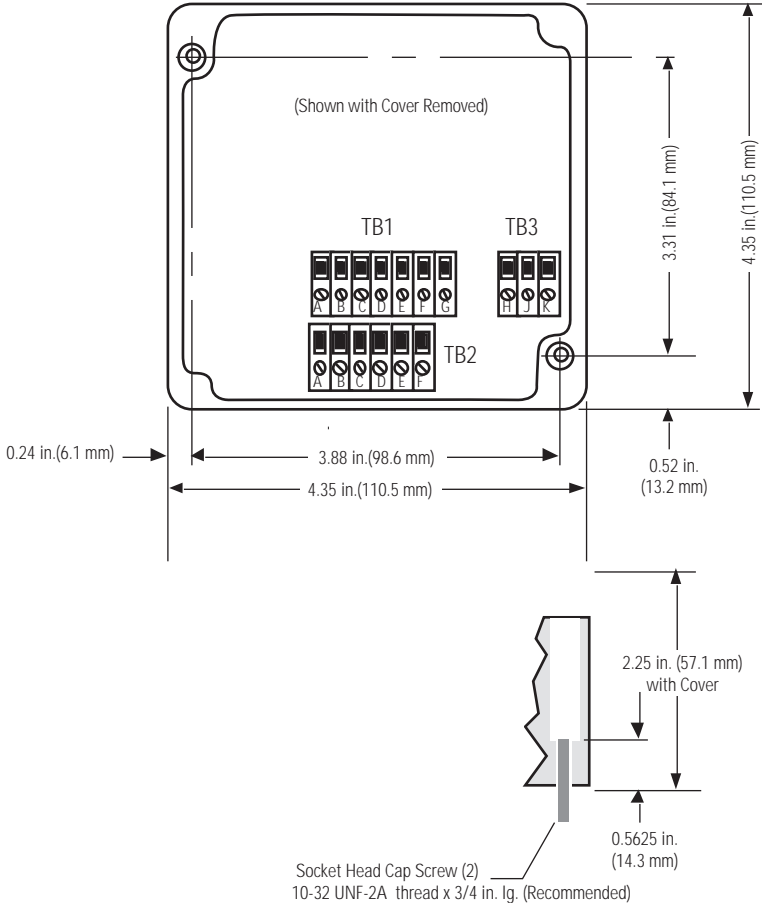
1. Move the permanent magnet to the desired position for Set Point 1. Press the SW1 push-button until the APM enters the programming mode (3 seconds) and acknowledges by producing an output voltage of about +5 volts. Release the SW2 button.
2. Press and release the SW2 button to enter the performance-mode setup mode. The APM will acknowledge by producing an output voltage which corresponds to the currently stored performance mode (see below). If the APM has never been programmed, the default mode will be resolution-preferred (that is, the output voltage will be 0 volts).

- Resolution Preferred Mode = 0 volts
- Balanced Mode = +8.4 volts
- Update Preferred Mode = -8.4 volts

3. At this point, repeated presses of the SW2 button will cause the APM to cycle through the three performance modes. Continue to press and release the SW2 button until the voltage output indicates the voltage associated with the correct mode for your application. Once the correct voltage is displayed, press and release the SW1 button to accept the mode setting. The APM acknowledges by producing an output voltage of approximately -4.2 volts.
4. Press and release the SW1 button to enter the Set Point 1 setup mode. The APM will acknowledge by producing an output voltage of about -2.1 volts.
5. At this point, you can use the SW1 and SW2 buttons to choose the voltage to assign to Set Point 1. Pressing and holding the SW1 button causes the output voltage to move in the positive direction; pressing and holding the SW2 button causes the output voltage to move in the negative direction. If either button is held for more than five seconds, the output voltage will begin to change more quickly. Release the button when the desired output voltage is displayed on the digital volt meter. (For testing purposes, it is not necessary to perform this step. It can be skipped entirely since it only assigns the final voltage to the Set Point.)
6. To complete the setup for Set Point 1, press and release both buttons simultaneously. Move magnet while looking at the output voltage. If output voltage changes, program has been locked in successfully. If output voltage does not change, put magnet back to the setpoint position and press both buttons simultaneously. If the transducer has been previously programmed, it will resume operation with the new voltage assigned to SW1. If it has not been previously programmed, it will return to the same voltage it had prior to entering the programming mode (near 0 volts).
7. Move the permanent magnet to the desired position for Set Point 2. Press the SW1 push-button until the APM enters the programming mode (3 seconds) and acknowledges by producing an output voltage of approximately +4.2 volts. Release the SW1 button.
8. Press and release the SW2 button to enter the performance-mode setup mode. The APM will acknowledge by producing an output voltage which corresponds to the currently stored performance mode. If the APM has never been programmed, the default mode will be resolution-preferred (that is, the output voltage will be 0 volts).
9. At this point, repeated presses of the SW2 button will cause the APM to cycle through the three performance modes. Continue to press and release the SW2 button until the voltage output indicates the voltage associated with the correct mode for your application. Once the correct voltage is displayed, press and release the SW1 button to accept the mode setting. The APM acknowledges by producing an output voltage of approximately -4.2 volts. (Note that the mode chosen in this step should be the same as the one chosen in step 3. If a different mode is chosen, it will overwrite the one chosen previously.)
10. Press and release the SW2 button to enter the Set Point 2 setup mode. The APM will acknowledge by producing an output voltage of +2.1 volts.
11. At this point, you can use the SW1 and SW2 buttons to choose the voltage to assign to Set Point 2. Pressing and holding the SW1 button causes the output voltage to move in the positive direction; pressing and holding the SW2 button causes the output voltage to move in the negative direction. If either button is held for more than five seconds, the output voltage will begin to change more quickly. Release the button when the desired output voltage is displayed on the digital volt meter. (For testing purposes, this step may be skipped completely.)
12. To complete the setup for Set Point 2, press and release both buttons simultaneously. Move magnet while looking at the output voltage. If output voltage changes, program has been locked in successfully. If output voltage does not change, put magnet back to the setpoint position and press both buttons simultaneously. If the transducer was previously programmed, it will resume operation with the new voltage assigned to Set Point 2.

## 8. Installing the Analog Output Module (AOM)

Dimensions of the AOM are shown below in Figure 8-1. The mounting hole dimensions shown are also stamped on the back of the module. Mount the AOM as shown, using two socket head cap-screws.



**Figure 8-1**  
**AOM Dimensions**

1. Mount the AOM in a location within reach of the LDT assembly cable. Standard systems allow the AOM to be mounted 250 feet from the LDT assembly.
2. Connect cable from AOM to the LDT assembly.
3. Adjust the AOM null and full-scale potentiometers (as described in Section 9) to compensate for any offsets due to mechanical installation.



## 9. Analog Output Module Adjustments

---

This section explains how to adjust and calibrate the Temposonics II LDT system using an AOM.

The AOM includes adjustments for null (zero), and full-scale (span). The adjustments compensate for the following:

- Differences between transducer gradients.
- Small offsets in the magnet position due to mounting.
- Wear in the moving parts of the mechanical system to which the magnet is attached.

In cases where a coupler device is used for adjusting the magnet, the coupler is used for coarse adjustments of both null and scale, while the AOM is used for fine adjustments.

### 9.1 Nominal Range of Adjustment

---

Null:            *Minimum:*  $\pm 3/8$  in.  
                  *Maximum:* Up to 10% of total stroke or  $\pm 2$  inches, whichever is smaller  
Full-scale:     $\pm 2\%$  of total stroke

Figure 9-1 (next page) shows the location of position adjustments and terminal boards on the AOM.

**NOTE:**

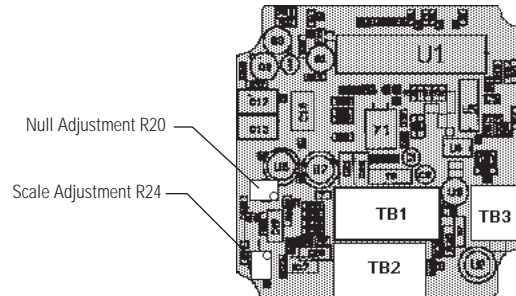
*Null adjustment has an overall effect on total scale adjustment. However, scale adjustment has no effect on null adjustment.*

## 9.2 Null and Full-Scale Adjustments

The following procedures calibrate the null position and the full-scale position to the required output levels. Refer to Figure 9-1 for the adjustment locations.

**NOTE:**

*The following procedure assumes the standard full-scale 0 to 10 Vdc output is supplied. When other output signals are supplied, use the appropriate signal levels and test equipment for the following adjustments.*

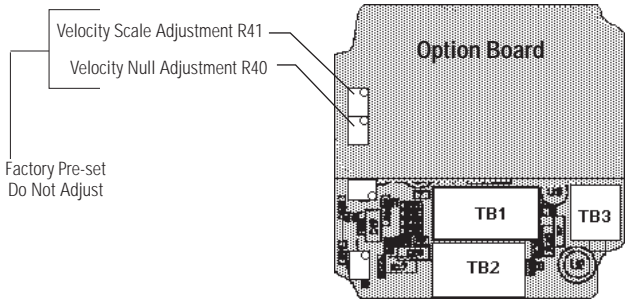


**Figure 9-1**  
**Location of Null & Scale Adjustments**  
**and Terminal Boards on the AOM.**

1. Disconnect all power from the system. Loosen the four screws securing the AOM cover, and remove the cover.
2. Note the location of terminal board TB1 on the AOM (Refer to Figure 9-1). Connect a DVM (digital voltmeter) across pins A and B of terminal board TB1 to monitor the displacement signal. Apply power to the system
3. Position the permanent magnet at the specified null position. The null position is specified when the LDT assembly is ordered (typically 2 inches from the transducer head).
4. Use a screwdriver to adjust the null potentiometer (R20) to increase or decrease the value, until you obtain a DVM reading of 0.000 Vdc.
5. Position the permanent magnet for full-scale position (typically 2 inches from the end of the LDT assembly).
6. Use a screwdriver to adjust the scale potentiometer (R24) to increase or decrease the value, until you obtain a DVM reading of +10.000 Vdc.
7. Repeat steps 3 to 6 to check the null and full-scale settings. Readjust as necessary.
8. Disconnect the DVM and check overall system operation. If no more adjustments are necessary, replace the AOM cover.

### 9.3 Velocity Null Adjustment

The AOM can be provided with an optional velocity output. For those units, velocity zero and span adjustments are provided. The velocity zero and velocity span adjustments are factory set and should not require readjustment. A velocity output signal of 0 (zero) volts represents a static displacement (no motion). A velocity output of 10 volts represents a dynamic displacement or a customer-specified maximum velocity (maximum velocity must be specified at time of order). The direction of motion is indicated by the polarity of the velocity signal; a positive output signal typically indicates that the permanent magnet is moving away from the transducer head (unless otherwise specified for this system). A negative output signal typically indicates that the permanent magnet is moving towards the transducer head.



**Figure 9-2**  
**Velocity Adjustments on the AOM**

## 10. Analog Output Module/ Wiring Procedures

---

This section describes wiring procedures for analog systems that use the Analog Output Module, including:

- 0 to 10 V displacement (forward and reverse acting)
- -10 to +10 V displacement (forward and reverse acting)
- Ungrounded 4 to 20 mA displacement
- Grounded 4 to 20 mA displacement
- Velocity Outputs
- Dual Channel Outputs

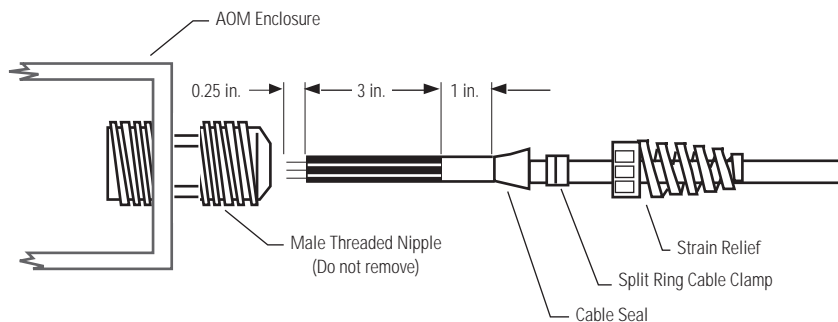
Connections are made between the transducer assembly, the AOM, the customer-supplied power supply, and the customer-supplied receiving device.

### 10.1 Preparing Cable for Connection to the AOM

---

The AOM is equipped with two strain relief or two MS (mil-spec) connectors.

A strain relief is used for an un-terminated cable. Prepare the cable as shown in Figure 10-1. It is recommended that you tin the exposed leads to ensure a good connection. Mount the cable to the AOM, ready to make connections to the terminal boards (TB1, TB2, or TB3) inside.



**Figure 10-1**  
**Cable Preparation for Strain Relief**

When the AOM box is used an optional MS connector can be used with the cable. Cables are available in various lengths from inventory.

## 10.2 J1 Installation Wiring

---

The J1 cable provides the AOM voltage inputs from the DC power supply. It also provides displacement outputs to the receiving device.

Take the following steps to connect J1:

1. One of the screws securing the cover of the AOM has a raised head. Connect a ground wire from that screw head to a central earth ground or to the power supply ground (if it is grounded). Only one circuit earth ground should be used to prevent ground loops. (Refer to Figure 5-1 of this manual for a full system grounding diagram.)
2. Strain Relief Only: Fabricate the J1 cable, and prepare the cable as described earlier. Identify the connections to TB1 and TB3. Refer to section 10.3 to determine the appropriate J1 connections.
3. MS Connector Only: Fabricate the J1 cable. Refer to section 10.4 to determine the appropriate J1 connections. Solder the connections to the MS type connector (Part No. 370017). Use any cable capable of maintaining the signals for the required length. Ensure the solder connections are clean and free of excessive solder. Use heat-shrink over the solder connections to prevent the pins from shorting.
4. Identify the wires at the other end of the cable for connections to the power supplies and the receiving device. Test the cable for shorts.

**NOTE:**

*Make sure that the power supply can provide +15 Vdc at 250 mA and -15 Vdc at 65 mA (use a bipolar power supply). The power supply should provide less than 1% ripple with 2% regulation. The power supply should be dedicated to the transducer system to prevent noise and external loads from affecting the system performance.*

5. Make sure the power supply is off. Complete the cable connections at the power supply.

**! CAUTION !**

*The input to the receiver electronics should be a passive, resistive device to prevent damage to the AOM.*

6. First, make sure there is no voltage present on the receiving device input connections. Then, complete the cable connections to the receiving device.

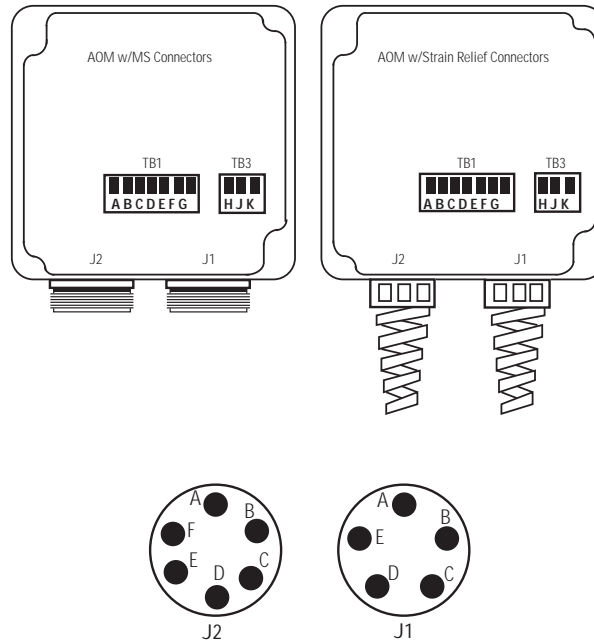
**NOTE:**

*Do not route the J1 cable near high voltage sources.*

7. Strain Relief Only: Connect the cable to the TB1 and TB3 terminals on the AOM.
8. MS Connector Only: Connect the cable to the J1 connector on the AOM.

### 10.3 J1 Connections for AOM

The AOM is provided with either a strain relief connector, which accepts a pigtailed connection directly into terminals blocks located inside the AOM enclosure, or a threaded MS connectors. Tables 10A through 10F, below, indicate the appropriate connection to make for either configuration. Make sure that you follow the appropriate table for your specified options.



**Figure 10-2**  
**AOM w/ Strain Relief and MS Connectors**

**Table 10A Standard J1 Connections**

<i>Strain Relief Connection</i>	<i>MS Connector Pin Designation (J1)</i>	<i>Function</i>
<i>TB1</i>		
A	D	Displacement Output
B	E	Displacement Output Return (ground)
<i>TB3</i>		
H	A	+ 15 Vdc
J	B	- 15 Vdc
K	C	DC Common

**Table 10B J1 Connections w/Velocity Output Option**

<i>Strain Relief Connection</i>	<i>MS Connector Pin Designation (J1)</i>	<i>Function</i>
<i>TB1</i>		
A	D	Displacement Output
B	-	Displacement Output Return (ground)
C	E	Velocity Output
D	-	Velocity Output Return (ground)
<i>TB3</i>		
H	A	+ 15 Vdc
J	B	- 15 Vdc
K	C	DC Common

**Table 10C J1 Connections w/24 V Power Supply Option**

<i>Strain Relief Connection</i>	<i>MS Connector Pin (J1)</i>	<i>Function</i>
<i>TB1</i>		
A	D	(+) Displacement Output
B	E	(-) Displacement Output
<i>TB3</i>		
H	A	24 Vdc
J	No Connection	N/A
K	C	DC Common

**Table 10D J1 Connections w/ 24 V Power Supply & Velocity Output Options**

<i>Strain Relief Connection</i>	<i>MS Connector Pin (J1)</i>	<i>Function</i>
<i>TB1</i>		
A	D	(+) Displacement Output
B	-	(-) Displacement Output
C	E	(+) Velocity Output
D	-	(-) Velocity Output
<i>TB3</i>		
H	A	24 Vdc
J	No Connection	N/A
K	C	DC Common

**Table 10E AOM J1 Connections w/Dual Channel Option**

<i>Strain Relief Connection</i>	<i>MS Connector Pin (J1)</i>	<i>Function</i>
<i>TB1</i>		
A	D	Channel 1 (+) Displacement Output
E	E	Channel 2 (+) Displacement Output
<i>TB3</i>		
H	A	+ 15 Vdc
J	B	- 15 Vdc
K	C	DC Common

**Table 10F J1 Connections w/Dual Channel & 24 V Power Supply Options**

<i>Strain Relief Connection</i>	<i>MS Connector Pin (J1)</i>	<i>Function</i>
<i>TB1</i>		
A	D	Channel 1 (+) Displacement Output
E	E	Channel 2 (+) Displacement Output
<i>TB3</i>		
H	A	24 Vdc
J	No Connection	N/A
K	C	DC Common

## 10.4 J1 Connection to AOM with MS Connectors

Table 10G Voltage Output

<i>Terminal Block Connections *</i>	<i>Pin Connection (J1)</i>	<i>Function #1 (w/Standard ± 15 Vdc P.S.)</i>	<i>Function #2 (w/Optional + 24 Vdc P.S.)</i>
TB3-H	A	+ 15 Vdc	+ 24 Vdc
TB3-J	B	- 15Vdc	-
TB3-K	C	DC Common	DC Common
TB3-A	D	Displacement Output	Displacement Output
TB1-B	E	Optional: velocity output	Optional: velocity output

Table 10H Ungrounded 4-20 mA Current Output

<i>Terminal Block Connections *</i>	<i>Pin Connection (J1)</i>	<i>Function #1 (w/Standard ± 15 Vdc P.S.)</i>	<i>Function #2 (w/Optional + 24 Vdc P.S.)</i>
TB3-H	A	+ 15 Vdc	+ 24 Vdc
TB3-J	B	- 15 Vdc	-
TB3-K	C	DC Common	DC Common
TB1-A	D	Current Output (source) <i>DO NOT ground or damage may result</i> <i>Maximum load resistance: 400Ω</i>	Current Output (source) <i>DO NOT ground or damage may result.</i> <i>Maximum load resistance: 400Ω</i>
TB1-B	E	Current Output (return)	Current Output (return)

Table 10I Grounded 4-20 mA Current Output

<i>Terminal Block Connections *</i>	<i>Pin Connection (J1)</i>	<i>Function #1 (w/Standard ± 15 Vdc P.S.)</i>	<i>Function #2 (w/Optional + 24 Vdc P.S.)</i>
TB3-H	A	+ 15 Vdc	+ 24 Vdc
TB3-J	B	- 15 Vdc	-
TB3-K	C	DC Common	DC Common
TB1-A	D	Current Output (source)	Current Output (source)
-	E	Not Used	Not used
		Maximum load resistance: 500Ω	Maximum load resistance: 500Ω

\* Terminal blocks are located inside the AOM housing and are accessed via strain relief connectors J1 and J2 on the face of the AOM.

## 10.5 J2 Connections

The J2 cable provides connections between the AOM and the transducer assembly.

Cables up to 250 feet (76 meters) can be fabricated with any high quality multi-conductor cable with an overall shield (Belden equivalent).

Take the following steps to connect J2:

1. It is recommended that you apply an earth ground to the transducer rod. This is typically accomplished by mounting the transducer head to a bracket or machine.
2. Strain Relief Only: If necessary, fabricate the J2 cable, and prepare the cable as described earlier. Identify the connections to TB2. Refer to Table 10J (next page) for the J2 connections.

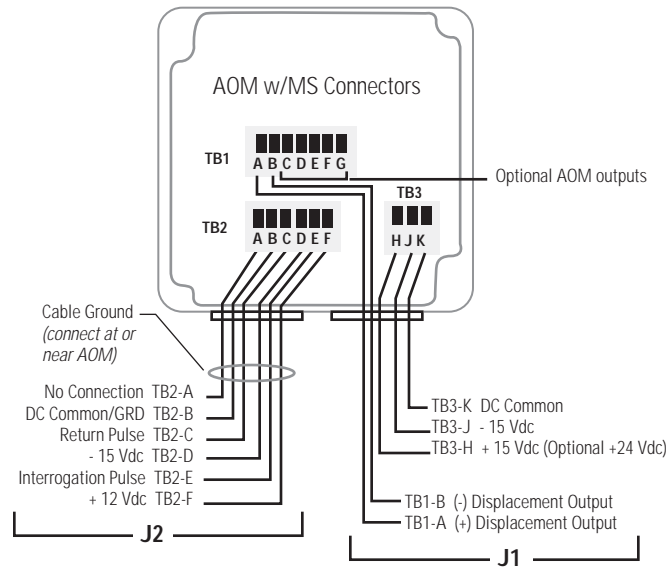
**NOTE:**

*Ensure the solder connections are clean and free of excessive solder. Use heat-shrink over the solder connections to prevent the pins from shorting.*



### 3. MS Connector Only:

If necessary, fabricate the J2 cable. Be sure to use the recommended cable for the required length. The color code refers to cables supplied with the system. Solder the connections to the MS connector supplied with the AOM. Use any cable capable of maintaining the signals for the required length. Ensure the solder connections are clean and free of excessive solder. Use heat-shrink over the solder connections to prevent the pins from shorting.



#### NOTE:

The connections to TB3 represent wiring for a typical system configuration (i.e., ±15 Vdc power supply and strain-relief connectors). If the AOM is configured with other options (i.e., 24 Vdc power supply, velocity output, MS connectors) refer to sections 10.3 and 10.4 for proper wiring.

**Figure 10.3**  
**AOM J1 and J2 Connections**

**Table 10J AOM J2 Connections**

J2 Connection (TB 2 A - F or J2 Pin A - F)		Wire Color Code *	Wire Color Code	*Function
Pin Connection	Terminal Block Connection			
J2 Pin A	TB2-A	Not Used	Not Used	No Connection
J2 Pin B	TB2-B	White/Blue Stripe	White	DC Common/GND
		Blue/White Stripe	Brown	Frame
		White/Brown Stripe	Black	
		Gray/White Stripe	Green	
J2 Pin C	TB2-C	Brown/White Stripe	Violet	Output Pulse
J2 Pin D	TB2-D	Green White Stripe	Blue	- 15 Vdc (- 13.5 to - 14.5 Vdc)
J2 Pin E	TB2-E	White/Gray Stripe	Yellow	Interrogation Pulse
J2 Pin F (see note 1)	TB2-F	White/Green Stripe	Red	+12 Vdc

\*Verify if the cable has striped or solid color leads and make connections accordingly.

#### NOTES:

1. Connect to TB2 Pin A if the stroke length exceeds 180 inches.

4. Strain Relief Only: Connect the cable to the TB2 terminals on the AOM and to the transducer.
5. MS Connector Only: Connect the cable to the J2 connector on the AOM, and to the transducer.
6. Apply power and check the displacement readings at the system electronics.

Table 10K Retrofit Connections -

Temposonics II Replacement of Existing Temposonics I with AOM

Temposonics II Integrated or Extension Cable (Notes 1, 2)				Analog Output Module (AOM)	
Pin No.	Wire Color Code	Wire Color Code	Functional Description	Terminal Blocks	Military Style (MS) Connectors
1	White/Blue Stripe	White	DC Ground	TB2-B	J2 Pin B
2	Blue/White Stripe	Brown	Frame (Note 3)	TB2-B	J2 Pin B
3	White/Orange Stripe	Gray	Not Used	Not Used	Not Used
4	Orange/White Stripe	Pink	Not Used	Not Used	Not Used
5	White/Green Stripe	Red	+Vdc	TB2-F (Note 4)	J2 Pin F (Note 4)
6	Green/White Stripe	Blue	-Vdc	TB2-D	J2 Pin D
7	White/Brown Stripe	Black	Return (GND)	TB2-B	J2 Pin B
8	Brown/White Stripe	Violet	Output (return pulse)	TB2-C	J2 Pin C
9	White/Gray Stripe	Yellow (See warning, below)	(+) Interrogation (Note 5)	TB2-E	J2 Pin E
10	Gray/White Stripe	Green (See warning, below)	(-) Interrogation (Note 6)	TB2-B	J2 Pin B

**NOTES:**

1. Verify if the cable has striped or solid color leads and make connections accordingly.
2. Cable: Belden #8105 or equivalent
3. Frame ground is isolated from circuit ground inside the electronics enclosure or head of the transducer.
4. Connect to TB2 Pin A if the stroke length exceeds 180 inches.
5. For retrofitting AOMs with stroke lengths greater than 12 inches in stroke length and positive (+) interrogation.
6. For retrofitting AOMs with stroke lengths greater than 12 inches in stroke length and negative (-) interrogation.
7. Shield: Connect extension cable shield at TB2-B or J2 Pin B.

**!WARNING!**

*Under no condition connect both the positive (+) and negative (-) interrogation wires to TB2-E at the same time. The unused interrogation lead MUST be connected to DC Ground.*

## 11. Troubleshooting the Analog Output Module

---

Use the troubleshooting procedures in this section when operational problems are encountered. The procedures are listed in order of frequency of occurrence, and should be completed in the order shown.

**NOTE:**

*The following procedures are for general diagnostic purposes. Purchase of replacement components should not be based solely on these procedures. Consult MTS Sensors Division for recommendations and factory service before ordering replacement components.*

### 11.1 General

---

Make sure the magnet is positioned to move freely along the LDT rod. Trace all wiring from the J1 connector to ensure proper routing.

### 11.2 Power Supply Check

---

Perform the following procedure to check the power supply voltages.

1. Remove power and disconnect connector J1 to check open circuit power supply voltages (as described in steps 2 and 3).

**NOTE:**

*If voltage is not present in steps 2 and 3, a problem with wiring or the power supply is indicated.*

2. Connect a DVM (digital voltmeter) to pins A and C of cable connector J1 if you have MS type connectors, or TB3 pins H and K if you have strain relief connectors. Apply power. The voltage should be +15 Vdc.
3. Connect the DVM to pins B and C of cable connector J1 if you have MS type connectors, or TB3 pins J and K if you have strain relief connectors. The voltage should be -15 Vdc.

**NOTE:**

*A low voltage reading in steps 4 and 5 indicates a power supply with an inadequate rating or an excessive voltage drop in the cabling (i.e. improper wire sizes).*

4. If the voltage readings are correct, check the power supply voltages under load (as described in steps 5 and 6).

5. Connect a 60  $\Omega$  to 75  $\Omega$  resistor across Pins A and C of the MS connector or pins H and K of TB3. The voltage across the resistor should be +14.7 Vdc (minimum).
6. Connect a 230  $\Omega$  to 250  $\Omega$  resistor across Pins B and C. The voltage across the resistor should be -14.7 Vdc (minimum).

### **11.3 Grounding**

---

Trace all ground and power supply common connections. A single earth ground should be connected to the power supply common (circuit ground). An additional ground is connected to the case of the analog output module (AOM). If the AOM is suspect, remove the mounting screws and place the box on insulating material (i.e. wood) then recheck the output readings.

### **11.4 Connections**

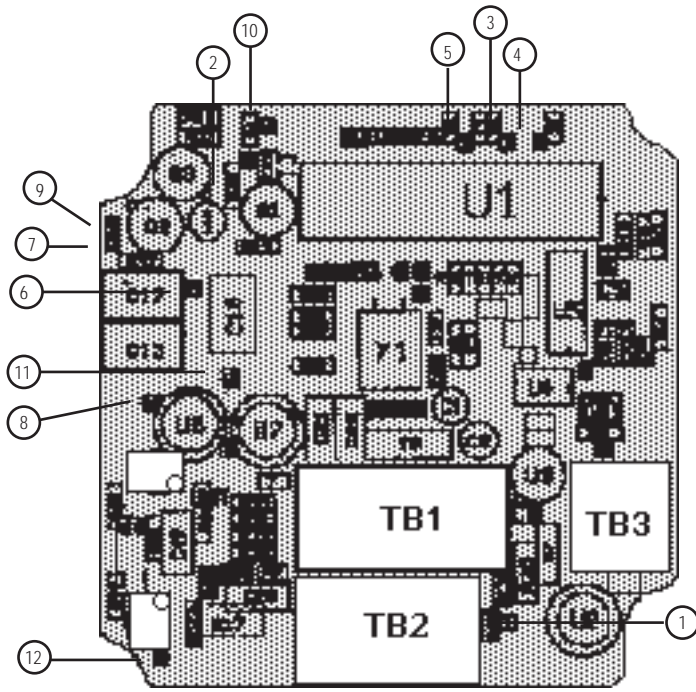
---

Check the solder connections in the J1 cable. Ensure no cold solder joints are present. Perform a continuity check between the J1 connections to ensure no shorts are present.

### **11.5 LDT Signals**

---

Disconnect connector J2 from the AOM. Apply power and check the J2 readings, using Figure 11-1. If the voltages are correct, connect J2 and check the signals at pins B and C with an oscilloscope.



**Figure 11-1**  
**Test Point (TP) Locations**

A		5 Volts at Test Point 1 0 Volts, TB3-K
B		3 - 5 Volt Interrogation pulse sent to TB2-E
C		Pulse returned from TB2-C (approximately 2-3 Volts)
D		TTL level pulse, 3-5 Volts located at Test Point 3
E		Pulse-width modulated output 3-5 Volts at Test Point 2
F		6 Volts at Test Point 6
G	Test Point #9: 0 to 10 Volts as the magnet moves back and forth.	
H	Test Point #12: 0 to 10 Volts or $\pm 10$ volts as the magnet moves back and forth. (The 4-20 mA Ungrounded option is 0 to 2 Volts)	
I	TB1-A: Same as H, above.	

**Figure 11-2**  
**AOM Signals**

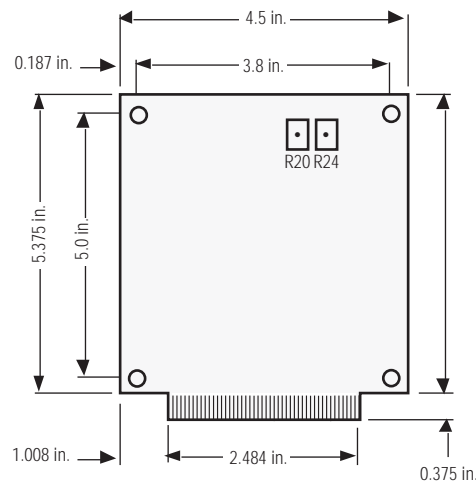
**NOTE:**

*Do not interchange transducers and AOMs with differing model numbers, without first consulting MTS Sensors Division.*

- A. If a spare transducer of the same stroke and model number is available, connect the spare transducer to the AOM and check the displacement readings at the system electronics.
- B. If a spare AOM of the same stroke model number is available, connect J1, J2 and the ground wire to the spare AOM and check the displacement readings at the system electronics.

## 12. Analog Output Card

The Analog Output Card is a plug-in type electronics card that performs the same functions as the Analog Output Module (AOM) and can be used as a direct replacement (physically and functionally) for the "old style" Temposonics Electronics Card.



**Figure 12-1**  
**Analog Output Card Dimensions**

The displacement output options available from the Analog Output Cards are as follows:

*Voltage Outputs:*

- 0 to 10 Vdc (forward and reverse acting)
- 0 to -10 Vdc (forward and reverse acting)
- -10 to +10 Vdc (forward and reverse acting)

*Current Outputs:*

- 4 to 20 mA ungrounded (forward and reverse acting)
- 4 to 20 mA grounded (forward and reverse acting)

Null (R20) and scale (R24) adjustments are available on the Analog Output Card.

*Null Adjustment:*

Using a digital voltmeter, turn potentiometer (R20) to increase or decrease the voltage output until null is set at 0.000 Vdc.

*Scale Adjustment:*

Using a digital voltmeter, turn potentiometer (R24) to increase or decrease the voltage output until full scale output is set at 10.000 Vdc.

The Analog Output Card has a 15 pin edge card connector, the function of each pin is as follows:

**Table 12A**  
**Analog Output Card Pin Identification**

<i>Pin No.</i>	<i>Function</i>
1	DC Ground (Current return for grounded systems)
2	+5 Vdc input (optional)
3	- 15 Vdc input
4	+12 Vdc to transducer (for strokes < 180 in.)
5	+15 Vdc input (+24 Vdc is optional)
6	+15 Vdc to transducer (for strokes ≥ 180 in.)
7	External reference input (optional)
8	-15 Vdc to transducer
9	+ Pulse width modulated signal (optional)
10	Dependent upon unit configuration. Options include: <ul style="list-style-type: none"> <li>• 4-20 mA ungrounded velocity return, or</li> <li>• Channel 2 return for dual channel displacement</li> </ul>
11	Dependent upon unit configuration. Options include: <ul style="list-style-type: none"> <li>• Velocity output (current source), or</li> <li>• Channel 2 output for dual channel displacement</li> </ul>
12	Analog displacement output (current source)
13	Displacement return for 4-20 mA ungrounded output systems
14	Output pulse
15	+ Interrogation pulse to transducer

**NOTE:**

The mating edge connector is MTS p/n 370034, and may be ordered by contacting the factory.

The connections from the Temposonics II transducer to the Analog Output Card are as follows:

**Table 12B**  
**Temposonics II Connection to Analog Output Card**

<i>Temposonics II Integrated or Extension Cable (see Note 1)</i>			
<i>Pin No.</i>	<i>Wire Color Code</i>	<i>Wire Color Code</i>	<i>Analog Output Card Pin No.</i>
1	White/Blue Stripe	White	1
2	Blue/White Stripe	Brown	1
5	White/Green Stripe	Red	4
6	Green/White Stripe	Blue	8
7	White/Brown Stripe	Black	1
8	Brown/White Stripe	Violet	14
9	White/Gray Stripe	Yellow	15
10	Gray/White Stripe	Green	1

**NOTES:**

1. Verify if the cable has striped or solid color leads and make connections accordingly.
2. Shield wire (drain) can be connected to Pin 1 on the Analog Output Card.





**MTS Systems Corporation**

Sensors Division  
3001 Sheldon Drive  
Cary, NC 27513  
Phone: 800-633-7609  
Fax: 919-677-0200  
Internet: [www.temposonics.com](http://www.temposonics.com)

**MTS Sensor Technologie GmbH and Co. KG**

Auf dem Schuffel 9, D-58513 Lüdenscheid, Germany  
Postfach 8130 D-58489 Lüdenscheid, Germany  
Phone: + 49-2351-95870  
Fax: + 49-2351-56491

**MTS Sensors Technology Corporation**

Izumikan Gobancho  
12-11 Gobancho  
Chiyoda-ku  
Tokyo 102  
Japan  
Phone: + 813 3239-3003  
Fax: + 813 3262-7780

Temposonics sensors are a registered trademark of MTS Systems Corporation  
All Temposonics sensors are covered by US patent number 5,545,984 and others.  
Additional patents are pending.

Part Number: 11-98 550032 Revision F  
© 1998 MTS Systems Corporation

