

# Level Plus<sup>®</sup>

Magnetostrictive Liquid Level Transmitters  
with Temposonics<sup>®</sup> Technology

**LevelLimit<sup>®</sup>**  
Operation Manual



## Table of contents

<b>1. Contact information</b>	<b>3</b>
<b>2. Terms and definitions</b>	<b>4</b>
<b>3. Introduction</b>	<b>6</b>
3.1 Purpose and use of this manual	6
3.2 Used symbols and warnings	6
<b>4. Safety instructions</b>	<b>6</b>
4.1 Intended use	6
4.2 Foreseeable misuse	7
4.3 Installation, commissioning and operation	7
<b>5. Product overview</b>	<b>8</b>
5.1 Components	8
5.2 Accuracy	10
5.3 Warranty	10
5.4 Storage	10
5.5 Model number identification	11
5.6 Technical data	12
5.7 Technical drawing	13
<b>6. Installation and mounting</b>	<b>15</b>
6.1 Training	15
6.2 Stilling wells and guide poles	15
6.3 Tools	15
6.4 Installation steps	15
6.5 Mounting	16
<b>7. Electrical connections</b>	<b>17</b>
7.1 Basic information	17
7.2 Safety recommendations	17
7.3 Industrial topologies	17
7.4 Cable recommendations	18
7.5 Electrical conduit	18
7.6 Grounding	19
7.7 Safety barriers	19
<b>8. Commissioning</b>	<b>20</b>
8.1 Training	20
8.2 Tools	20
8.3 Setup software	20
8.4 Commissioning steps	20
<b>9. Maintenance</b>	<b>20</b>
9.1 Training	20
9.2 Tools	20
9.3 Inspection	21
9.4 Preventative maintenance	21
<b>10. Repair</b>	<b>22</b>
10.1 RMA policy	22
10.2 Training	22
10.3 Tools	22
10.4 Troubleshooting	22
10.5 Setup software	23
<b>11. Spare Parts</b>	<b>23</b>
<b>12. Interface</b>	<b>23</b>
12.1 Modbus output	23
<b>13. Agency information</b>	<b>24</b>
13.1 Approvals overview	24
13.2 Certificates	25
13.3 FM (NEC)	25
13.4 FMC (CEC)	30
13.5 ATEX and IECEx	36

## 1. Contact information

### United States

#### General

Tel: +1-919-677-0100  
Fax: +1-919-677-2343  
E-mail: [info.us@mtssensors.com](mailto:info.us@mtssensors.com)  
<http://www.mtssensors.com>

#### Mailing and shipping address

MTS Systems Corporation  
Sensors Division  
3001 Sheldon Drive  
Cary, North Carolina, 27513, USA

#### Customer service

Tel: +1-800-633-7609  
Fax: +1-800-498-4442  
E-mail: [info.us@mtssensors.com](mailto:info.us@mtssensors.com)

#### Technical support and applications

24 Hour Emergency Technical Support  
Tel: +1-800-633-7609  
E-mail: [levelplus@mts.com](mailto:levelplus@mts.com)

### Germany

#### General

Tel: +49-2351-9587-0  
Fax: +49-2351-56491  
E-mail: [info.de@mtssensors.com](mailto:info.de@mtssensors.com)  
<http://www.mtssensors.com>

#### Mailing and shipping address

MTS Sensor Technologie GmbH & Co. KG  
Auf dem Schüffel 9  
58513 Lüdenscheid, Germany

#### Technical support and applications

Tel: +49-2351-9587-0  
E-mail: [info.de@mtssensors.com](mailto:info.de@mtssensors.com)  
<http://www.mtssensors.com>

## 2. Terms and definitions

### 6A Heavy Oils

'Generalized Crude Oils', Correction of Volume to 60 °F against API Gravity.

### 6B Light Oils

'Generalized Products', Correction of Volume to 60 °F against API Gravity.

### 6C Chemical

'Volume Correction Factors (VCF)' for individual and special applications, volume correction to 60 °F against thermal expansion coefficients.

### 6C Mod

An adjustable temperature reference for defining VCF.

## A

### API gravity

The measure of how heavy or light a petroleum liquid is compared to water. Allowable values are 0 to 100 degrees *API* for (6A) and 0 to 85 degrees *API* for (6B).

## D

### DDA (Direct Digital Access)

The proprietary digital protocol developed by MTS for use in intrinsically safe areas.

### Density

Mass divided by the volume of an object at a specific temperature. The density value should be entered as lb / cu. ft..

### Digital I/O

Represents a binary input and output signal that is either in a high or low state. The LevelLimit generates an output signal that is HI when the switch float is sitting at rest on the stop collar and LO when switch float is no longer at rest.

## E

### Explosion proof

Type of protection based on enclosure in which the parts which can ignite an explosive gas atmosphere are placed within, and which can withstand the pressure developed during an internal explosion of an explosive mixture, and which prevents the transmission of the explosion to the explosive gas atmosphere surrounding the enclosure.

## F

### Flameproof

Type of protection based on enclosure in which the parts which can ignite an explosive gas atmosphere are placed within and which can withstand the pressure developed during an internal explosion of an explosive mixture, and which prevents the transmission of the explosion to the explosive gas atmosphere surrounding the enclosure.

## G

### GOVI (Gross Observed Volume of the Interface)

The total volume of the tank occupied by the interface liquid. The *GOVI* is only given when measuring two liquids and is calculated by subtracting the volume of the product from the total volume of liquid in the tank ( $GOVT - GOVP$ ).

### GOVP (Gross Observed Volume of the Product)

The total volume of the tank occupied by the product liquid. When measuring only one liquid, it is also the total volume of liquid in the tank (*GOVT*). When measuring two liquids it is the total volume of liquid in the tank minus the volume of the interface liquid ( $GOVT - GOVI$ ).

### GOVT (Total Gross Observed Volume)

The total volume of liquid in the tank. When measuring only one liquid it is equal to the volume of the product (*GOVP*). When measuring two liquids it is equal to the volume of the product and interface liquids ( $GOVP + GOVI$ ).

### GOVU (Gross Observed Volume Ullage)

The difference in volume between the working capacity of a tank and the total volume in the tank ( $Working\ Capacity - GOVT$ ).

## H

### HART®

A *Bidirectional communication protocol* that provides data access between intelligent field instruments and host systems.

## I

### Interface

*Noun*; The measurement of the level of one liquid when that liquid is below another liquid.

### Interface

*Adj.*; The Software *Graphical User Interface* (GUI) that allows the user to access software protocols (*HART®*, *DDA*, *MODBUS*).

### Intrinsic safety

'Intrinsically safe' - Type of protection based on the restriction of electrical energy within apparatus of interconnecting wiring exposed to potentially explosive atmosphere to a level below that which can cause ignition by either sparking or heating effects.

## M

### Mass

The property of a body that causes it to have weight in a gravitational field, calculated by density at the reference temperature multiplied by the volume correction factor ( $Density \times VCF$ ).

### MODBUS

A *serial communications protocol* published by Modicon in 1979 for use with its programmable logic controllers (PLCs). It has become a de facto standard communications protocol in industry, and is now the most commonly available means of connecting industrial electronic devices.

## N

### NEMA Type 4X

A product *Enclosure* intended for indoor or outdoor use primarily to provide a degree of protection against corrosion, windblown dust and rain, splashing water, and hose-directed water; and to be undamaged by the formation of ice on the enclosure. They are not intended to provide protection against conditions such as internal condensation or internal icing.

### NPT

*U.S. standard* defining tapered pipe threads used to join pipes and fittings.

### NSVP (Net Standard Volume of the Product)

The temperature corrected volume for the product liquid in the tank, requires the transmitter to be ordered with temperature measurement capabilities. The *NSVP* is calculated by multiplying the volume of the product liquid by a volume correction factor based on temperature ( $GOVP \times VCF$ ).

## R

### Reference Temperature

The *temperature* at which the density measurement is given, the allowable values are 32 °F to 150 °F (0 °C to 66 °C).

## S

### Specific Gravity

The *density ratio* of a liquid to the density of water at the same conditions.

### Sphere Radius

The *internal radius* of the sphere that contains the liquid, the value is used to calculate the volume along with the *Sphere Offset*.

### Sphere Offset

An *offset value* that accounts for additional volume in a sphere from non-uniform sphere geometry, the value is used to calculate the volume along with the *Sphere Radius*.

## Strap Table

A *table of measurement* correlating the height of a vessel to the volume that is contained at that height. The transmitter can contain up to 100 points.

## T

### TEC

'Thermal Expansion Coefficient' - a value correlating the change in temperature for an object with the change in its volume. Allowable values are 270.0 to 930.0. TEC units are in 10 E-6/Deg F.

### Temperature Correction Method

One of five *product correction methods* used to correct the product volume in the tank due to changes in temperature from 60 °F including (6A, 6B, 6C, 6C Mod, and Custom Table).

## V

### Volume Calculation Mode

One of two methods use to calculate volume measurements from level measurements, including *Sphere* and *Strap Table*.

### VCF (Volume Correction Factor)

A table of measurements correlating temperature points with correction factors for the liquids expansion/contraction. The transmitter can contain up to 50 points.

## W

### Working Capacity

The *maximum volume of liquid* that the user desires for their vessel to hold, typically 80 % of the vessels maximum volume before overflow.

### 3. Introduction

#### 3.1 Purpose and use of this manual

**Important:**

Before starting the operation of the equipment read this documentation thoroughly and follow the safety information.

The content of this technical documentation and of its various annexes is intended to provide information on mounting, installation and commissioning by qualified service personnel according to IEC 60079-14 and local regulations or MTS trained service technicians.

#### 3.2 Used symbols and warnings

Warnings are intended for your personal safety and for avoidance of damage to the described product or connected devices. In this documentation, safety information and warnings to avoid dangers that might affect the life and health of personnel or cause material damage are highlighted by the preceding pictogram, which is defined below.

Symbol	Meaning
<b>NOTICE</b>	This symbol is used to point to situations that may lead to material damage and/or personal injury.

### 4. Safety instructions

#### 4.1 Intended use

The liquid level transmitter is intended to be used to measure the level of liquid(s) contained by a structure as well as the temperature of the liquid. The product may only be used for the applications defined under item 1 to item 4 and only in conjunction with third-party devices and components recommended or approved by MTS Sensors. As a prerequisite of proper and safe operation, the product requires correct transport, storage, mounting and commissioning and must be operated with utmost care.

1. Application does not exceed product's performance specification in chapter 5.6.
2. Product may only be installed in hazardous areas as specified by approval certifications in chapter 13 following special conditions of use outlined in chapter 13 or in safe areas.
3. The liquid(s) being measured are compatible with the selected wetted parts of the product.
4. MTS floats should be used for proper functionality and safety approval.

#### 4.2 Foreseeable misuse

Foreseeable misuse	Consequence
Wrong sensor connection	Possible damage to electronics See chapter 7 for Electrical Connections
Improper Installation	Physical damage to packaging See chapter 6 for Installation
Installation in unapproved Hazardous Area	Potential Spark See chapter 13 for Agency Information
Process Temperature out of range	Signal Degradation, Possible Damage to Sensor See chapter 5.6 for Specifications
Power Supply out of range	No Communication, Possible Damage to Sensor See chapter 5.6 for Specifications
Process Pressure out of range	Possible Damage to Sensor, See chapter 5.6 for Specifications
Improper Chemical Compatibility	Possible Damage to Sensor, Customer Must Select Wetted Material that is compatible with liquid(s) in tank
Modifying Sensor	Warranty Void, Hazardous Approval Void Customer should contact factory for custom unit
Improper Grounding	Possible Damage to Sensor, Full Protection Compromised, See chapter 7.6 for Grounding
Improper Installation of HI Level Switch	HI Level Switch is not able to move freely from the intended location and does not properly signal overfill situations. Potential is for a tank overfill.

Table 1: Foreseeable misuse

#### 4.3 Installation, commissioning and operation

1. Wear proper personal protection equipment such as hard hat, safety shoes, flame resistant clothing, safety glasses, gloves, and hearing protection.
2. Follow the specifications given in the technical documentation.
3. Two (2) individuals are recommended to conduct proper installation, commissioning, and repair of the level transmitter.
4. Ensure the equipment used in a hazardous environment is selected and installed in compliance with regulations governing the geographical installation and facility. Only install equipment that complies with the types of protection relevant to the applicable classes, division, zones, category, gas group, and temperature code.
5. Protect the sensor against mechanical damage during installation and operation.
6. Do not use damaged products and secure them against unintentional use. Mark damaged products as being defective.
7. Connect the sensor very carefully and pay attention to the polarity of connections. MTS recommends to not make connections while power is live.
8. Before turning on power, ensure that nobody's safety is jeopardized by starting level transmitter and/or process.
9. Regularly follow preventative maintenance to prevent safety risks
10. Make sure that no wire strands are loose or sticking out of the terminal block connection which could short and cause a problem.
11. Make sure that no wire strands, including shield, are in contact with the electronic module enclosure.

## 5. Product overview

The Level Plus® LevelLimit® Liquid-Level transmitter is a continuous multi-functional magnetostrictive transmitter that product level, interface level, temperature, and volume to the user via Modbus. Magnetostrictive technology is one of the most accurate and repeatable level technologies available to date.

The LevelLimit® also includes a HI level switch that is used for overflow protection via a Digital I/O signal. When the HI level float is raised approximately 25 mm (1 in.) from its base position the Digital I/O opens and the controller can detect that a HI level has been detected in order to enter into a shut down procedure.

MTS is the inventor and purveyor of magnetostrictive technology and has been serving the level industry for over 35 years.

### Industries

- Petroleum
- Liquid Petroleum Gas
- Pharmaceutical
- Food & Beverage
- Chemical
- Mining

### Applications

- Tank Farms
- Terminals
- Bullet Tanks
- Separator Tanks
- Battery Tanks
- Storage Tanks

### Features

- 5-in-1 Measurement
  - Product Level
  - Interface Level
  - Temperature
  - Volume
  - Integral HI Level Digital I/O
- No scheduled maintenance or recalibration
- Field Repairable
- Level Inherent Accuracy +/-1mm
- 200 Point Strap Table
- API Temperature Corrected Volumes
- Explosion proof
- Intrinsically Safe

## 5.1 Components

The Level Plus® LevelLimit® liquid level transmitter consists of four main components; a housing, outer pipe, float, and electronics. Varying the components of the transmitter allows the transmitter to be customized to almost any application.

### Housings

Level Plus® LevelLimit® transmitters are available with a dual-cavity housings as shown below:

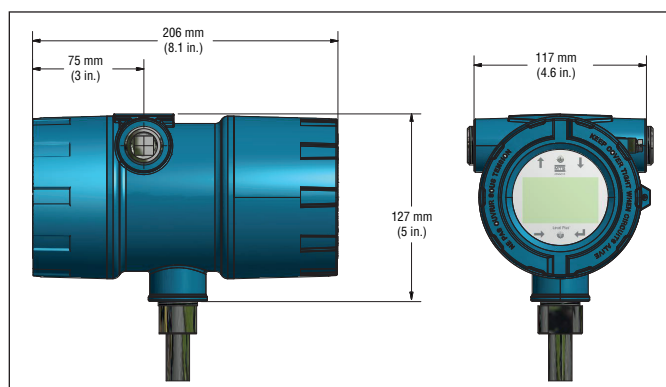

Fig. 1: Dual cavity housing



**Outer pipe configurations**

The outer pipe is constructed of a variety of configurations. The LevelLimit® is available in a flexible hose or a rigid pipe.

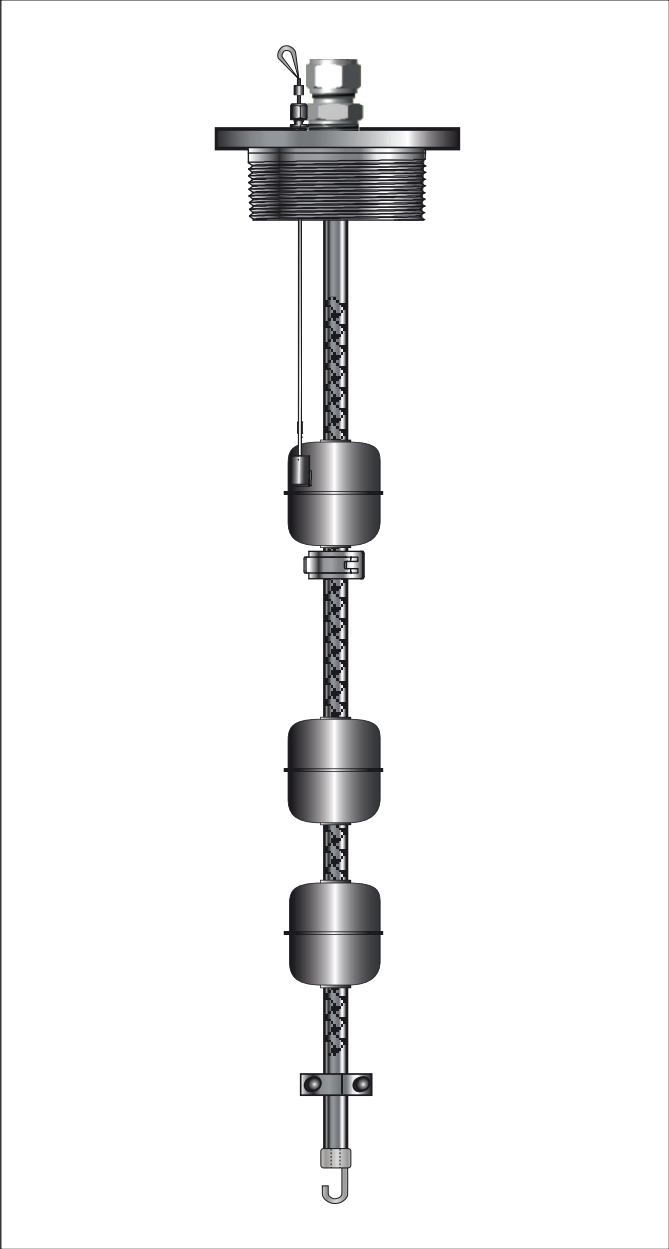

Fig. 2: Outer pipe configuration

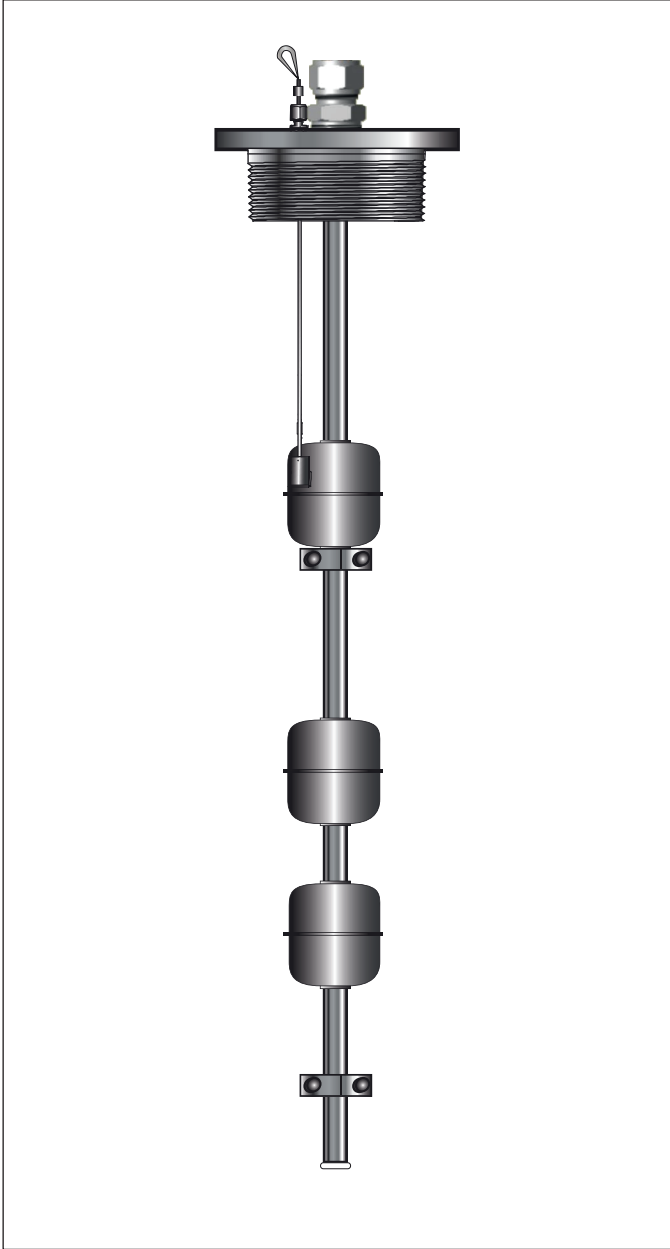

Fig. 3: Outer pipe configuration

## Floats

LevelLimit® transmitters offer numerous floats for different applications such as stainless steel and Hastelloy® for both product level and interface level. To be able to accurately detect the interface level there needs to be a difference of at least 0.05 in specific gravities between the product and interface liquids. For detailed information about floats, refer to the 'Accessories Catalog', (MTS Part # 551103).

For assistance with selecting a specific float for your application, please contact Technical Support with the following information:

- Specific gravity of liquid(s) being measured
- Process temperature
- Process opening size
- Vessel pressure

LevelLimit® transmitters should be used with a float having an offset weight and made of stainless steel or Hastelloy® C. This allows the float to stay in contact with the pipe to prevent the buildup of an electrostatic charge. For detailed information about floats, refer to the 'Accessories Catalog', (MTS Part #551103).

## Internal electronics

All transmitters come with two electronic components of a sensing element and a board set. Flexible sensing elements are standard for the flexible hose option and rigid sensing elements are standard for the rigid pipe option. The board set consists of up to three electronic boards and a display.

The LevelLimit® includes a secondary sensing element that is used for detecting a high tank level. The HI level switch includes a separate electronic board and sensing element.

A temperature sensing function is optional with the LevelLimit® transmitter. The temperature sensing device is a Digital Thermometer mounted inside the transmitter's outer pipe assembly. The LevelLimit® can be ordered with 1, 5, 12, or 16 temperature points.

## Display

All LP-Series liquid level transmitters are shipped with a stylus (MTS Part # 404108) to be used for manipulating the display. The stylus is designed to allow for programming of the unit without removing the housing. When using the stylus make sure to align the stylus with the shape outline around the buttons in the same orientation. Failure to correctly align the stylus can cause the display to not function properly. Password for entering the menu is 27513. For additional details consult the protocol specific Modbus Interface Manual (MTS Part #551700).

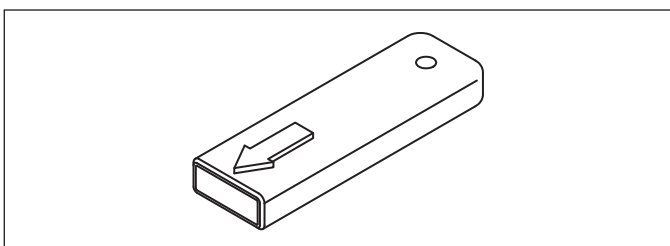

Fig. 4: Stylus (MTS Part # 404108)

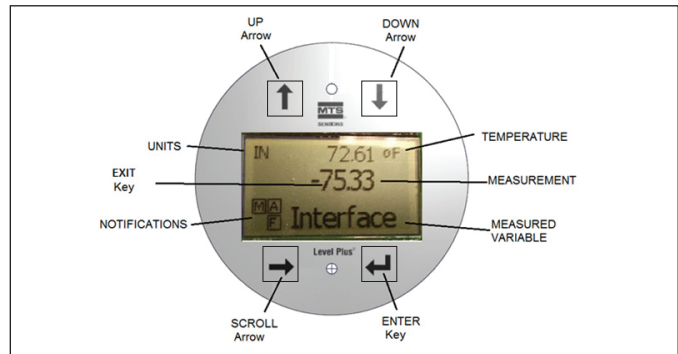

Fig. 5: Display

## Accessories

MTS also offers a series of displays, housings, converters, and other accessories, please refer to the 'Accessories Catalog', (MTS Part #551103).

### 5.2 Accuracy

For magnetostrictive transmitters inherent accuracy is measured in terms of non-linearity. Non-linearity is a measurement of any imperfections in the waveguide that are reflected in the linearity of the transmitter's output. MTS tolerances reflect a maximum non-linearity of  $\pm 1$ mm. MTS is able to achieve such strict tolerances by manufacturing all of its own waveguide from a proprietary alloy and testing 100% of all transmitters before shipping.

### 5.3 Warranty

#### Important:

Contact Technical Support or Customer Service for assistance if you suspect that the transmitter is not working correctly. Technical support can assist you with troubleshooting, part replacement, and Returned Material Authorization (RMA) information if required.

All Level Plus® transmitters come with a two year limited warranty from the factory shipment date. An additional extended warranty can be purchased. A Return Materials Authorization (RMA) number is required and must accompany any transmitter returns. Any unit that was used in a process must be properly cleaned in accordance with OSHA standards, before it is returned to the factory. A Material Safety Data Sheet (MSDS) must also accompany the transmitter that was used in any process.

### 5.4 Storage

If storage is required prior to installation, store indoors in a dry environment at ambient temperature range not to exceed  $-40...+71^{\circ}\text{C}$  ( $-40...+160^{\circ}\text{F}$ ).

### 5.5 Model number identification

1	2	3	4	5	6	7	8	9	10	11	12	13	14	15	16	17	18	19	20	21	22															
L	P	L																																		
a			b			c			d			e			f			g			h			i			j				k		l			

a	Sensor model
L P L	LevelLimit Level Transmitter

b	Sensor pipe
B	5/8" OD Rigid Pipe
M	Flexible, 7/8"OD tube w/bottom fixing eye
N	Flexible, 7/8"OD tube w/bottom fixing weight
P	Flexible, 7/8"OD tube w/bottom fixing magnet
S	Flexible, 7/8"OD tube w/o bottom fixing hardware

c	Process connection size
G	4 in. NPT adjustable
X	None

d	Number of DT's (Digital Thermometers)
0	None
1	One DT
5	5 DTs
K	Twelve DTs
M	Sixteen DTs

e	DT's placement
F	Evenly spaced per API
C	Custom
X	None

f	Notified body
C	CEC (FMC)
E	ATEX
F	NEC (FM)
I	IEC
X	None

#### NOTICE

Accessories such as floats, cables, and remote displays have to be ordered separately. All accessories are shown in the Accessories Catalog (551103).

\*/ Contact factory for other materials

g	Protection method
F	Explosion proof / Flameproof - PENDING
I	Intrinsically safe
X	No approval

h	Gas group
A	Group A (not available with "C = CEC (FMC)" notified body and "F = Flameproof/Explosion" proof protection method)
B	Group B
C	Group C
D	Group D
3	IIC (Intrinsically Safe only)
4	IIB + H2 (Explosion Proof / Flameproof only)
X	None

i	Unit of measure
M	Millimeters (Metric)
U	Inches (US customary)

j	Length (no decimal spaces)
X X X X X	Flexible sensor pipe: 1575...22000 mm (code as 01575 to 22000)
X X X X X	Flexible sensor pipe: 62...866 in. (code as 06200 to 86600)
X X X X X	Rigid sensor pipe: 305...7620 mm (code as 00305 to 76200)
X X X X X	Rigid sensor pipe: 12...300 in. (code as 01200 to 30000)

k	Special
S	Standard product

l	HI Level Switch Position
X X X X X	Flexible sensor pipe: 1575...22000 mm (code as 01575 to 22000)
X X X X X	Flexible sensor pipe: 62...866 in. (code as 06200 to 86600)
X X X X X	Rigid sensor pipe: 305...7620 mm (code as 00305 to 76200)
X X X X X	Rigid sensor pipe: 12...300 in. (code as 01200 to 30000)

<b>5.6 Technical data</b>	
<b>Level Output</b>	
Measured Variable	Product level and interface level
Output Signal /Protocol	Modbus RTU
Order Length	Flexible hose: 1575...22000 mm (62...866 in.) Rigid pipe: 305...7620 mm (12...300 in.)
Inherent Accuracy	±1 mm (0.039 in.)
Repeatability	0.001% F.S. or 0.381 mm (0.015 in.) whichever is greater (any direction)
<b>Temperature Output</b>	
Measured Variable	Average and multipoint temperatures
Temperature Accuracy	±0.2 °C (0.4 °F) range -40...-20 °C (-40...-4 °F), ±0.1 °C (0.2 °F) range -20...+70 °C (-4...+158 °F), ±0.15 °C (0.3 °F) range +70...+100 °C (+158...+212 °F), ±0.5 °C (0.9 °F) range +100...+105 °C (+ 212 ...221 °F)
<b>Digital I/O</b>	
Input Voltage	Up to 30 VDC
Resistance	500 Ohm
Current Switch Capability	50 mA @ 28 VDC
Compatibility	ABB RMC 100, Emerson ROC 827, Xetawave I/O, and others
Cable	Cat5 or equivalent type cable is required (15pF/ft. or 49pF/m) for a max run of 4000 ft. (1200 m)
<b>Electronics</b>	
Input Voltage	10.5...28 VDC
Fail Safe	High, Full scale
Reverse Polarity Protection	Series diode
EMC	EN 61326-1, EN 61326-2-3, EN 61326-3-2, EN 61000-6-2, EN 61000-6-3, EN 61000-4-2, EN 61000-4-3, EN 61000-4-4, EN 61000-4-5, EN 61000-4-6, EN 61000-4-8, EN 61000-4-11
<b>Environmental</b>	
Enclosure Rating	NEMA Type 4X, IP65
Humidity	0...100% relative humidity, non-condensing
Operating Temperatures	Electronics: -40...+71 °C (-40...+160 °F) Sensing element: -40...+125 °C (-40...+257 °F) (contact factory for specific temperature ranges) Temperature element: -40...+105 °C (-40...+221 °F)
Vessel Pressure	Flexible Hose: 30 bar (435 psi) Rigid Pipe: 69 bar (1000 psi)
Materials	Wetted parts: 316L stainless steel (contact factory for alternative materials) Non-wetted parts: 316L stainless steel, Epoxy coated aluminum
<b>Field Installation</b>	
Housing Dimensions	Dual cavity: 117 mm (4.6 in.) W × by 127 mm (5 in.) D × 206 mm (8.1 in.) H
<b>Mounting</b>	
Flexible hose or Rigid pipe	4 in. adjustable MNPT
<b>Wiring</b>	
Connections	Terminal block
<b>Electrical connections</b>	
Dual cavity	¾ in. FNPT conduit opening, M20 for ATEX/IECEx version
<b>Display</b>	
Measured variables	Product level, interface level and temperature

5.7 Technical drawing

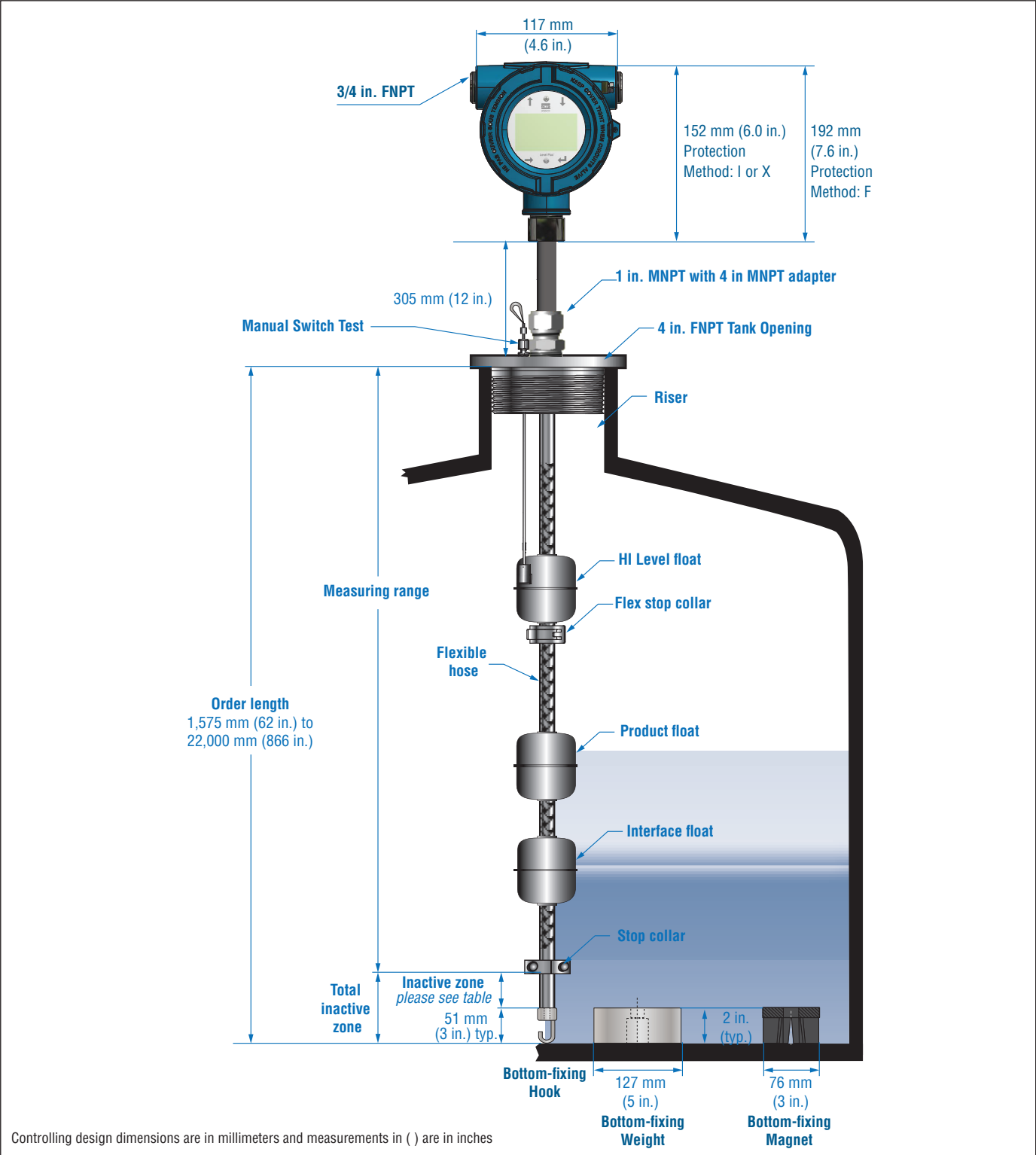

TRANSMITTER INACTIVE ZONE REFERENCE

Order Length	Inactive Zone
<7.6 m (25 ft.)	76 mm (3 in.)
7.6 m to 12.2 m (25 to 40 ft.)	97 mm (3.8 in.)
12.3 m to 22 m (40 to 72 ft.)	120 mm (4.7 in.)

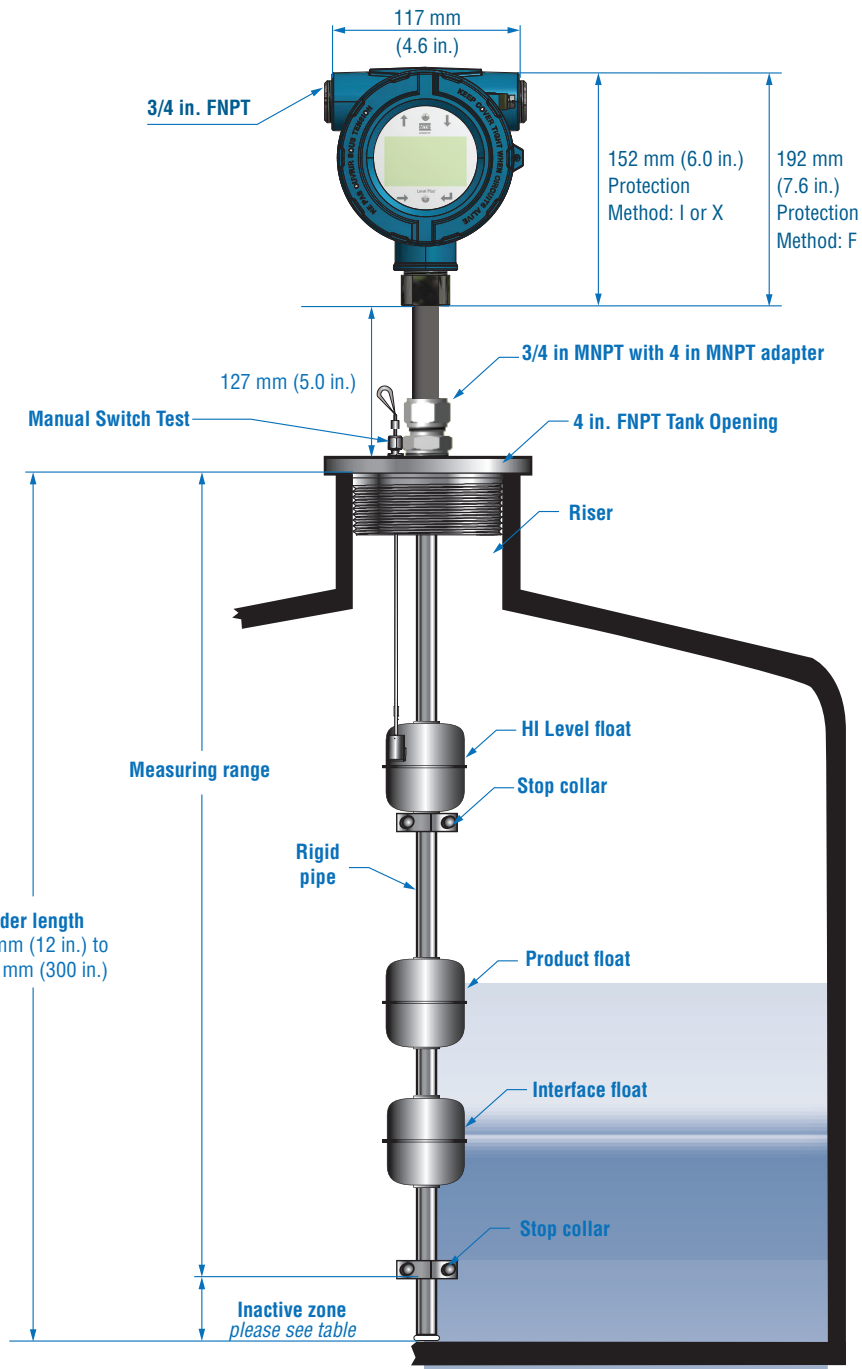

Controlling design dimensions are in millimeters and measurements in ( ) are in inches

## TRANSMITTER INACTIVE ZONE REFERENCE

Order Length	Inactive Zone
<7.6 m (25 ft.)	76 mm (3 in.)

## 6. Installation and mounting

### 6.1 Training

#### **Warning:**

When the pipe/hose of the LP-Series level transmitter is installed or removed from the tank the release of flammable vapors will occur. Take all necessary precaution when installing or removing the level transmitter due to the release of flammable vapors.

Installation should only be conducted by qualified service personnel according to IEC 60079-14 and local regulations or MTS trained service technicians. MTS offers web based and in person training for installation, commissioning, maintenance, and repair. MTS also offers factory direct services for these same functions. Contact MTS to discuss training or factory direct services before starting.

### 6.2 Stilling wells and guide poles

Level Plus® transmitters can be mounted in slotted or unslotted stilling wells but a slotted stilling well is always preferred. Using a unslotted stilling well will negatively affect performance of any level device as the level in the stilling well can differ from the level in the tank. The Level Plus® transmitter can also be installed to one side of the stilling well to also allow for sampling and manual gauging from the same opening as the automatic tank gauging. Contact technical support for details.

Level Plus® transmitters do not require a stilling well for installation. Our transmitters are installed in numerous tanks without stilling wells with no loss in performance due to our patented flexible waveguide and hose. A stilling well is highly recommended for agitated, turbulent, and/or fast filling tanks.

### 6.3 Tools

#### 6.3.1 Flexible Hose Tools

- 9/16" Socket and ratchet
- Channel Lock pliers
- 3/16" Hex Key (Allen wrench)
- 1" Open End wrench

#### 6.3.2 Rigid Pipe Tools

- Channel Lock pliers
- 9/64" Hex Key (Allen wrench)
- 3/4" Open End wrench
- Common head screwdriver, slotted screwdriver

### 6.4 Installation steps

#### **Caution:**

When assembling and installing the LevelLimit® transmitter, be careful not to allow the flexible hose to kink or be coiled in less than 381 mm (15 in.) diameter. It is recommended that assembly and mounting of this transmitter should not be done alone. To ensure proper and safe assembly of the LevelLimit® transmitter, a minimum of two (2) individuals are recommended. Gloves are also recommended. PPE may be required for work areas such as safety shoes, safety glasses, hard hat, and fire resistant clothing.

1. Consult chapter 4.3 before starting.
2. Perform steps 1-10 in chapter 8.4.1
3. Remove stop collar, nut, washer, spacer, and flex stop collar from flexible hose. Alternatively, remove stop collars and e-ring from rigid pipe. Do not remove the adjustable fitting from the hose or pipe.
4. Slide 4" NPT adapter, HI level float, and cable assembly onto level transmitter. onto flexible hose or rigid pipe and move the adapter to the top. To prevent damage to the level transmitter keep the assembly toward the end of the level transmitter.
5. Slide the product float onto the flexible hose or rigid pipe. Slide the interface float (optional) onto the flexible hose or rigid pipe. Install stop collar 76 mm (3 in.) from the tip of the rigid section of the flexible hose or the rigid pipe. Do not drop float(s) or allow them to free fall along the flexible hose or rigid pipe as damage may result.

#### **NOTICE**

The bottom stop collar can be removed or adjusted based on the float selected for the application. Please consult the factory for more information.

6. For the flexible hose mount the hook section of the pipe (this is the bottom rigid section of the pipe) using the supplied nut, spacer and washer, tighten securely as shown in Fig. 6, Fig. 7 and Fig. 8. For the magnet, remove washer before installing in tank.
7. Slide float(s) and 4" NPT adapter assembly back down to the stop collar to prevent them from free falling during installation into the tank. Insert the flexible hose or rigid pipe and floats through the tank opening and lower the transmitter/float assembly into the tank until it rests on the bottom. If you are using a bottom-fixing hook, fasten the hook to the appropriate customer-supplied mating hardware at the tank bottom.
8. Connect the 3/4" NPT (rigid) or the 1" NPT (flex) to the 4" NPT adapter assembly. Tighten the adjustable NPT fitting to the 4" NPT adapter.
9. Pull the level transmitter up far enough to add the flex stop collar or second rigid stop collar over the marking on the pipe. The top of the stop collar should align with the top of the marking.
10. Lower level transmitter down inside of tank. Tighten the 4" adapter to the tank.
11. Loosen the Cord Grip on the 4" adapter and make sure the cable and float move up and down with ease. Tighten cord grip.

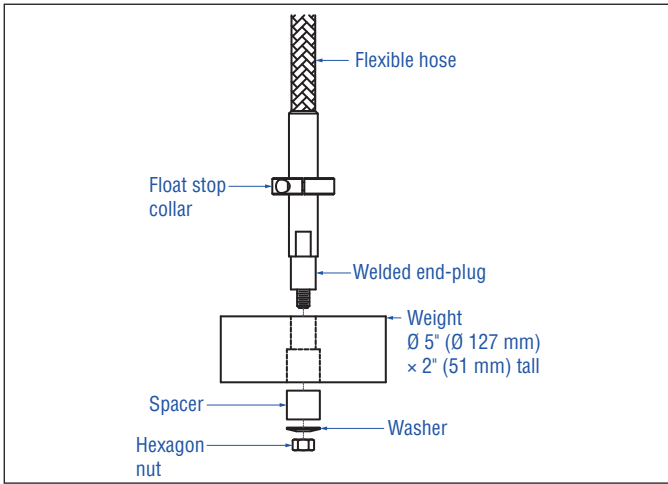

Fig. 6: Bottom fixing weight

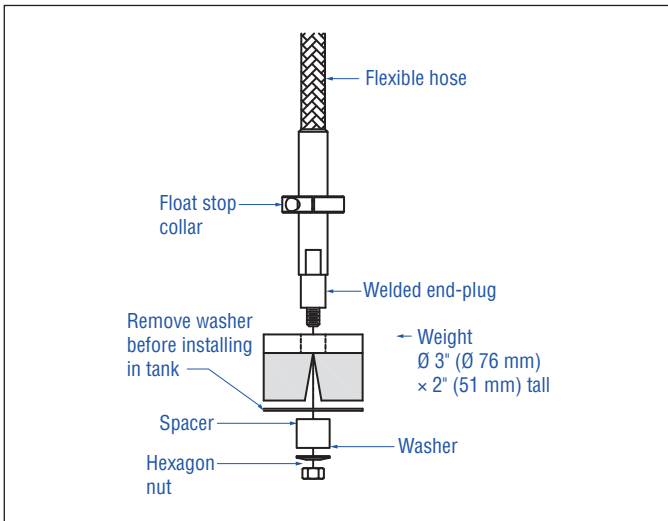

Fig. 7: Bottom fixing magnet

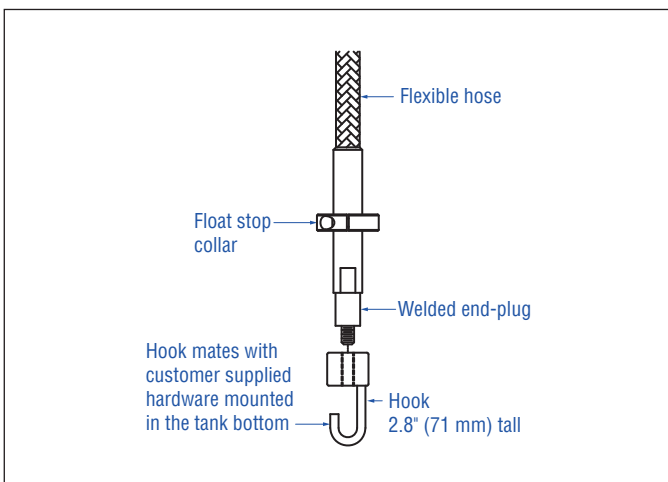

Fig. 8: Bottom fixing hook

**Warning:**

When the pipe/hose of the LP-Series level transmitter is installed or removed from the tank the release of flammable vapors will occur. Take all necessary precaution when installing or removing the level transmitter due to the release of flammable vapors.

12. Pull the transmitter upward to straighten the flexible hose until the resistance of the weight, magnet, or hook is felt without raising the weight or magnet off the floor of the tank. Tighten the adjustable fitting to hold the transmitter in place. For the rigid pipe, pull the transmitter upward until the pipe is straight and the tip of the pipe touches the bottom of the tank. Tighten the adjustable fitting. Once the fitting is tightened it is no longer adjustable and cannot be moved.
13. Terminate the field wire cables noting proper wire orientation. Wiring diagram is shown in Section 13.

Consult Section 5.7 Technical Drawing to reference what the finished installation should look like.

**6.5 Mounting**

The method of mounting the transmitter is dependent on the vessel or tank in which it is being used, and what type of transmitter is being mounted. For LevelLimit there is only the standard 4" NPT mount that allows for the functionality of the HI level switch manual test.

**Threaded flange mounting**

The LevelLimit® transmitter can be mounted directly to the tank or flange via a NPT threaded fitting, assuming there is a proper threaded connection available as shown in section 5.7. If the float will not fit through the flange opening when the flange is removed, there must be some alternative means to mount the float on the transmitter from inside the vessel; this may require an access port nearby the entry point of the transmitter.



## 7. Electrical connections

### 7.1 Basic information

A typical intrinsically safe connection for the Level Plus® LevelLimit® transmitter includes protective safety barriers, a power supply and a reading or monitoring device. Refer to Agency information in chapter 13.

A typical Explosionproof/flame proof connection for the Level Plus® LevelLimit® transmitter includes a power supply and a reading or monitoring device. All cabling is in approved conduit with sealoffs as specified by local electrical code. Refer to agency information in chapter 13.

### 7.2 Safety recommendations

#### Be sure to:

1. Always follow applicable local and national electrical codes and observe polarity when making electrical connections.
2. Never make electrical connections to the LevelLimit® transmitter with power turned on.
3. Make sure that no wire strands are loose or sticking out of the terminal block connection which could short and cause a problem.
4. Make sure that no wire strands, including shield, are in contact with the electronic module enclosure.
5. The electronics module enclosure is grounded through internal circuitry and is electrically isolated from the explosionproof housing.

### 7.3 Industrial topologies

There are four topologies described and illustrated below. However, the daisy chain topology is not recommended by MTS. The topologies are shown for the Modbus communication of the level transmitter. MTS recommends running independent cable runs for each HI Level Switch in the network.

#### Point-to-point

The point-to-point topology consists of having only one device on the loop as shown in Fig. 91. This topology is not usually used with a bus network since it does not take advantage of placing multiple devices on a loop.

#### Bus with spurs

The bus with spurs topology has a main trunk cable that has each

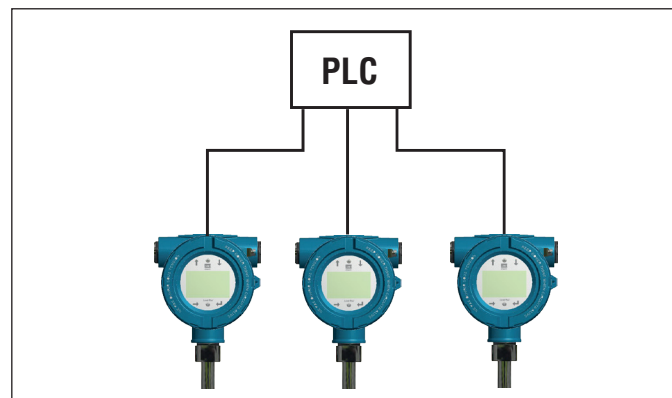

Fig. 9: Point-to-point topology

device connected via its own spur at a junction box as shown in Fig. 102. The bus with spurs and tree topologies can also be used together to form a hybrid topology.

#### Tree alignment

The tree topology is very similar to the bus with spurs topology with

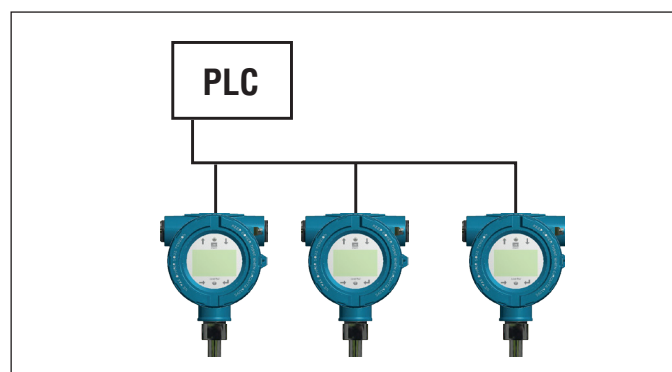

Fig. 10: Bus with spurs topology

the main difference of having a common junction box for all of the transmitters as shown in Fig. 113. Bus with spurs and tree topologies can also be used together to form a hybrid topology.

**Daisy chain**

The daisy-chain topology utilizes a single cable that is connected to

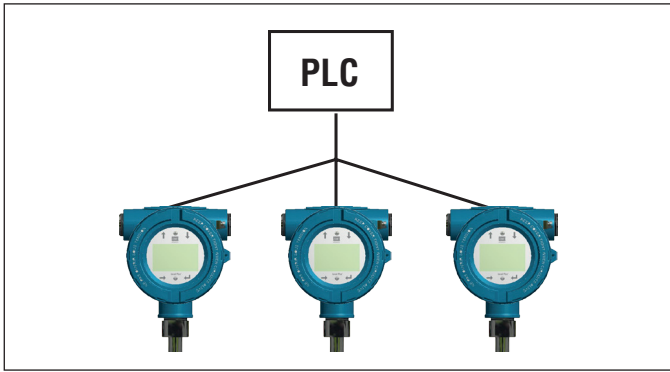

Fig. 11: Tree topology

all of the transmitters with the cable being interconnected at each field device. When using this topology make sure that the wiring practice allows for one transmitter to be disconnected without disconnecting the entire loop as shown in Fig. 124. MTS does not suggest using the daisy-chain topology.

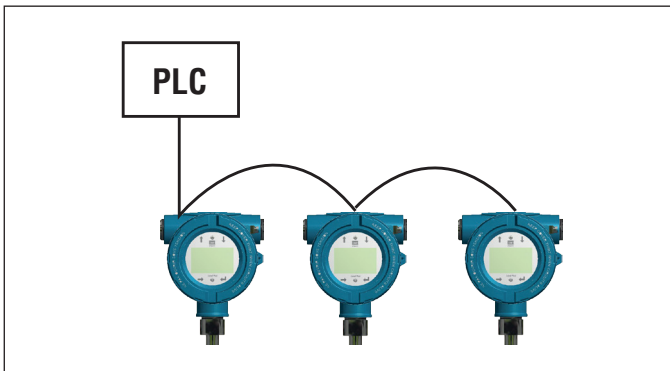

Fig. 12: Daisy-chain topology

**7.4 Cable recommendations**

Refer to 'Table 2' below for general requirements of cable types for the Level Plus® LevelLimit® analog transmitter.

**Cable specifications Modbus communication**

Parameter	Specification
Minimum cable size	Ø 0.51...1.6 mm (24...14 AWG)
Cable type	Single pair shielded or multiple pair with overall shield; minimum 0.25 mm (0.010 in.) insulation thickness
Capacitance	Less than 98 pF/m (30 pF/ft)

Table 2: Cable specification and parameters

**Cable specifications Digital I/O**

Cable Type	Cat5 or equivalent type cable
Capacitance	Less than 15 pF/ft. (49 pF/m)

Table 3: Cable specifications Digital I/O

**7.5 Electrical conduit**

**NOTICE**

1. Tighten housing cover (both front and back covers if dual cavity) to full stop against the O-ring.
2. Do not over-tighten compression fittings.
3. Use side conduit entry only.
4. In high humidity areas, use a breather drain type conduit sealing fitting to minimize moisture intrusion.
5. For Division Installations, an approved conduit seal is required within 457 mm (18 in.) of the enclosure.
6. For Zone Installations, an approved conduit seal is required within 50 mm (2 in.) of the enclosure.

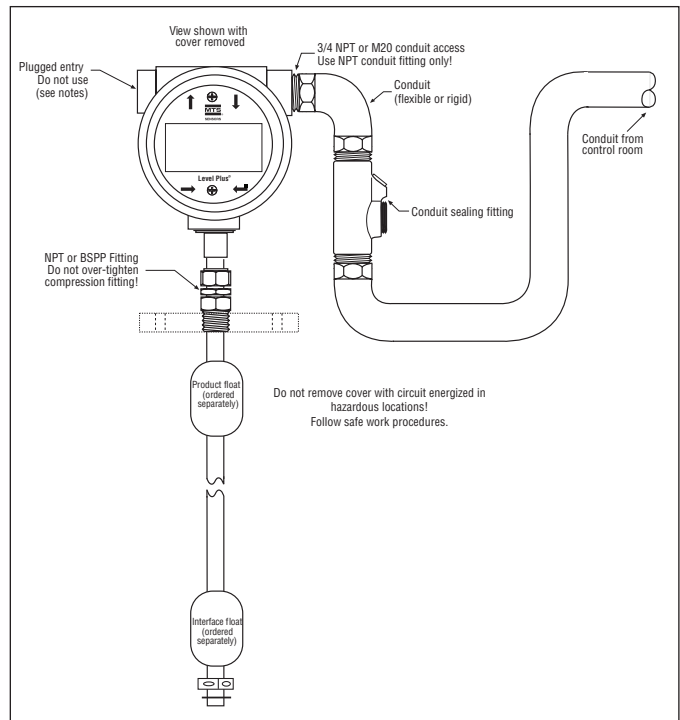

Fig. 13: Electrical conduit installation

## 7.6 Grounding

### 7.6.1 Safety grounding

**Warning:**

Grounding the transmitter through a threaded conduit connection does not meet the requirements as a grounding of the sensor for safety.

There are two methods to provide an earth ground connection to the earth ground of the electronics. Either method must result in a resistance of less than 1 Ω.

- Run an earth ground through the conduit and connect directly to the earth ground lug inside the housing.
- Run an earth ground directly to the ground lug on the outside of the housing.

### 7.6.2 Shield grounding

**Warning:**

The shield ground does not meet the requirements as grounding of the sensor for safety.

Immunity performance of the sensor from external sources of surge, burst, RF, radiated emissions and other noise is dependent on a proper ground for the shield of the communications cable. The communications cable shield should be of a braided type and connected to the internal ground lug of the sensor housing.

#### Runs in a continuous metallic conduit

When installed inside a dedicated continuous metallic conduit, the conduit provides a level of shielding protection from external interference and a level of ground to the sensor housing. In this case a foil type shielded cable with a drain wire connected to the internal ground lug may be sufficient. Sharing of the metallic conduit with other cables will result in loss of effective shielding performance of the communication cable and possible degradation in performance of the sensor. In this case a braided type shielded cable connected to the sensor internal ground lug would be recommended. In all cases paralleling the communications cable with any noise generating cable inside of a conduit or with noise generating cables in close proximity to the conduit may degrade the performance of the sensor.

#### Runs without a conduit

In some rare applications, or where safety may not be required, a metallic conduit may not exist. The communications cable shield should be of a braided type and connected to the internal ground lug of the sensor housing. Alternatively a safety approved EMC Cable Gland can be used for grounding the shield. Contact MTS for information before using one of these cable glands.

#### NEC

Undesirable currents (ground loops) is a violation of the NEC and is a safety hazard.

## 7.7 Safety barriers

Refer to Table 4 for entity parameters and Table 5 for example safety barriers

Entity parameters	
Digital supply (1 per LT)	U <sub>i</sub> = 28 VDC
	I <sub>i</sub> = 100 mA
	C <sub>i</sub> = 0.0 μF
	L <sub>i</sub> = 0 mH
	P <sub>i</sub> = 700 mW
Digital communication (2 per LT)	U <sub>i</sub> = 8.6 VDC
	I <sub>i</sub> = 10 mA
	C <sub>i</sub> = 0.0 μF
	L <sub>i</sub> = 0.0 mH
	P <sub>i</sub> = 21.5 mW
Digital I/O (1 per LT)	U <sub>i</sub> = 28 VDC
	I <sub>i</sub> = 50 mA
	C <sub>i</sub> = 0.083 μF
	L <sub>i</sub> = 8.5 mH
	P <sub>i</sub> = 350 mW
	R = 666 Ohm

Table 4: Safety barrier entity parameter references

Supplier	Stahl	Stahl	Stahl
Type	9001/01-280-100-101	9001/01-086-010-101	9001/01-280-050-101
Maximum voltage	28 VDC	8.6 VDC	28 VDC
Maximum current (each channel)	100 mA	10 mA	50 mA
Maximum power (each channel)	700 mW	21.5 mW	350 mW
Number of channels	1	1	1
Interface	Modbus	Modbus	Digital I/O

Table 5: Safety barrier entity parameter references

## 8. Commissioning

### 8.1 Training

Commissioning should only be conducted by qualified service personnel according to IEC 60079-14 or MTS trained service technicians and local regulations. MTS offers web based and in person training for installation, commissioning, maintenance, and repair. MTS also offers factory direct services for these same functions. Contact MTS to discuss training or factory direct services before starting.

### 8.2 Tools

#### 8.2.1 Tools for Flexible Hose

- 9/16" Socket and ratchet
- Channel Lock pliers
- 3/16" Hex Key (Allen wrench)
- 1" Open End wrench
- RS485 to USB Converter (MTS Part # 380114)[Modbus and DDA]
- Windows Based PC
- Linear Regulated Power Supply
- MTS Setup Software
- 

#### 8.2.2 Tools for Rigid Pipe

- Channel Lock pliers
- 9/64" Hex Key (Allen wrench)
- 3/4" Open End wrench
- RS485 to USB Converter (MTS Part # 380114)[Modbus and DDA]
- Windows Based PC
- Linear Regulated Power Supply
- MTS Setup Software

### 8.3 Setup software

MTS offers Setup Software that is shipped with the level transmitter and is also available for download from [www.mtssensors.com](http://www.mtssensors.com). The Setup Software is to be used for installation, commissioning, and troubleshooting. For further details on how to use the setup software consult the Modbus Interface Manual (MTS Part# 551700).

#### NOTICE

For Additional details consult the protocol specific Modbus Interface Manual (MTS Part #551700).

### 8.4 Commissioning steps

#### 8.4.1 Modbus

1. Consult chapter 4.3 before starting.
2. Remove level transmitter from shipping container.
3. Remove bottom fixing nut, washer, spacer, and stop collars.
4. Insert flexible hose or rigid pipe into float(s) making sure float(s) are in the active range. Install product float first.
5. Connect power, RS485 to USB converter, and PC.
6. Open MTS Setup Software.
7. Establish Communication.
8. Set Address, Enter Strap Table, Setup Volume Correction Method. Default address 247.
9. Disconnect Power and Communication. Remove floats. Prepare level transmitter for transport to the top of the tank.
10. Complete Installation in chapter 6.4.
11. Have qualified technician perform hand measurement. Enter hand measurement into MTS Setup Software and calibrate.
12. Store all settings as backup file according to site name and tank number.

#### 8.4.2 Digital I/O

1. Connect Power
2. Place float on level transmitter with float bottom at the top of the mark on the pipe.
3. Verify Digital I/O is HI.
4. Remove float and verify Digital I/O is LO.
5. Disconnect power.
6. Complete installation in chapter 6.4

## 9. Maintenance

### 9.1 Training

Maintenance should only be conducted by qualified service personnel according to IEC 60079-14 and local regulations or MTS trained service technicians. MTS offers web based and in person training for installation, commissioning, maintenance, and repair. MTS also offers factory direct services for these same functions. Contact MTS to discuss training or factory direct services before starting.

## 9.2 Tools

### 9.2.1 Tools for Flexible Hose

- 9/16" Socket and ratchet
- Channel Lock pliers
- 3/16" Hex Key (Allen wrench)
- 1" Open End wrench

### 9.2.2 Tools for Rigid Pipe

- Channel Lock pliers
- 9/64" Hex Key (Allen wrench)
- 3/4" Open End wrench

## 9.3 Inspection

Below are some standard items that should be inspected on a regular basis to make sure that the level transmitter and surrounding environment are in operating condition.

- Hazardous Area Label is present and legible
- Hazardous Area approval is correct for installation
- There are no visible unauthorized modifications
- Electrical connections are tight
- Condition of enclosure gasket is satisfactory
- No water ingress (white powder)
- No obvious damage to cable
- Sealing of conduit or cable gland is satisfactory
- Earth ground is satisfactory
- Single or Dual Cavity Enclosure threads are not damaged
- Housing and O-ring are not damaged or cracked
- No corrosion on visible parts
- Printed circuit boards are clean and undamaged
- Manual HI Level test cable present and not damaged
- Cord Grip connected to 4" NPT adapter and tight

## 9.4 Preventative maintenance

Level Plus® level transmitters do not typically require preventative maintenance but may require preventative maintenance dependent on the application. For general purpose applications where there is no potential for buildup on the flexible hose and/or float there is no need for preventative maintenance but routine inspection is still suggested. For severe service applications where there is potential for buildup on the flexible hose and/or float then preventative maintenance is required.

## 9.4.1 General purpose applications

### 9.4.1.1

Perform Inspection suggested in chapter 9.3.

### 9.4.1.2

No additional preventative maintenance is necessary. Preventative maintenance suggested for Severe Service Applications may be performed.

### NOTE

It is best to clean the hose/pipe as it is removed from the tank to minimize the amount of product that is removed from the tank. The user should take caution and abide by all regulations so that product is not spilled and the environment is not contaminated.

## 9.4.2 Severe Service Applications

### 9.4.2.1

Perform Inspection suggested in chapter 9.3.

### 9.4.2.2

Disconnect Power.

### 9.4.2.3

Disconnect process connection from tank. Remove flexible hose or rigid pipe from tank.

### 9.4.2.4

When the bottom of the hose/pipe is reached inspect the floats.

#### 9.4.2.4.1

If the floats are highly contaminated then remove the assembly from the tank and remove the floats from the hose/pipe.

#### 9.4.2.4.2

If the floats are slightly contaminated then clean the floats without removing the floats from the hose/pipe.

### 9.4.2.5

Replace flexible hose or rigid pipe and floats in tank.

### 9.4.2.6

Connect process connection to tank.

### 9.4.2.7

Connect Power.

### 9.4.2.8

The process should be carried out regularly until a consistent pattern has been established as to how long the intervals between cleanings should be.

## 10. Repair

### 10.1 RMA policy

**Important:**

Contact Technical Support or Customer Service for assistance if you suspect that the transmitter is not working correctly. Technical support can assist you with troubleshooting, part replacement, and Returned Material Authorization (RMA) information if required.

All Level Plus® transmitters come with a two year limited warranty from the factory shipment date. A Return Materials Authorization (RMA) number is required and must accompany any transmitter returns. Any unit that was used in a process must be properly cleaned in accordance with OSHA standards, before it is returned to the factory. A Material Safety Data Sheet (MSDS) must also accompany the transmitter that was used in any process.

### 10.2 Training

Repair should only be conducted by qualified service personnel according to IEC 60079-14 and local regulations or MTS trained service technicians. MTS offers web based and in person training for installation, commissioning, maintenance, and repair. MTS also offers factory direct services for these same functions. Contact MTS to discuss training or factory direct services before starting.

### 10.3 Tools

#### 10.3.1 Tools for Flexible Hose

- 9/16" Socket and ratchet
- Channel Lock pliers
- 3/16" Hex Key (Allen wrench)
- 1" Open End wrench

#### 10.3.2 Tools for Rigid Pipe

- Channel Lock pliers
- 9/64" Hex Key (Allen wrench)
- 3/4" Open End wrench

## 10.4 Troubleshooting

Symptom	Possible cause	Action
No communication with transmitter	No power	Check voltage at transmitter
	Wiring incorrect	Reference installation drawing chapter 13
	Wrong address	DDA factory default is '192' Modbus factory default is '247'
	Wrong software	Confirm correct software
Missing magnet error or Alarm output	Wrong protocol	Confirm software and transmitter are same protocol
	Float not recognized	Confirm that the float is attached
	Float is in the dead zone	Raise float to see if the error stops
Trigger level error	Wrong number of floats selected	Confirm that the number of floats on the transmitter and the number of floats the transmitter is attempting to verify are the same.
	Gain needs to be adjusted	Consult Factory
	SE is damaged	Consult Factory
Volume calculation error	Min. trigger level too high	Consult Factory
	No strap table entered	Enter strap table
	Level outside range of strap table	Enter additional points in strap table
VCF error	Strap table incorrect	Check value entries
	No VCF table entered	Enter VCF table
Digital I/O constant LO	VCF table incorrect	Check VCF value entries
	Float misaligned	Check hi level float and hi level stop collar are mounted at pipe marking Possible Cause -
Digital I/O HI during manual test	No Power	Check voltage at transmitter
	Cable damaged	Check cable is attached to float and moving during manual test

Table 6: Troubleshooting reference

## 10.5 Setup software

MTS offers Setup Software that is shipped with the level transmitter and is also available for download from [www.mtssensors.com](http://www.mtssensors.com). The Setup Software is to be used for installation, commissioning, and troubleshooting. or further details on how to use the setup software consult the Modbus Interface Manual (MTS Part# 551700).

## 11. Spare Parts

Below are the spare parts list for the LP-Series shown as the display, electronic module, sensing element, and flexible hose. Please contact MTS Technical Support with any questions.

Spare part		Part number
Display		254732
Output	Housing	Part number
Modbus	A, B, C, D, E	254731-3
Modbus	L	254731-7
Digital I/O	All	254875

Table 7: Spare parts

### Sensing Element

Change third digit in Model Number from L to E.

For example, the sensing element for model number LPLNG0XFIAU50000S42500 is LPENG0XFIAU50000S42500.

### Flexible Hose

Change third digit in Model Number from L to P.

For example, the replacement flexible hose for model number LPLNG0XFIAU50000S42500 is LPPNG0XFIAU50000S42500.

## 12. Interface

### 12.1 Modbus output

This Operation and Installation Manual focuses on the mechanical installation of the LevelLimit® level transmitter. The Modbus Interface Manual (MTS Part# 551700) had detailed information about the Modbus RTU network.

## 13. Agency information

### 13.1 Approvals overview

The Notified Body is designated in the 8<sup>th</sup> digit of the model number and the Protection Method is designated in the 9<sup>th</sup> digit of the model number. These two digits of the model number specify the hazardous area approval that is provided with the selected level transmitter. Shown below are the detailed approval information for the NEC, CEC, IEC, and ATEX approvals. Please contact MTS with any questions about the hazardous approval needed.

Notified body	Protection method	Classification	Standard
C = CEC	I = Intrinsic Safety	Class I, Division 1, Groups ABCD T4 Class I, Zone 0/1, Ex ia IIC T4 Ta = -50°C to 71°C IP65	CAN C22.2 No. 157-92:2012 CSA C22.2 No. 1010.1:2004 CAN/CSA C22.2 No. 60079-0:2011 CAN/CSA C22.2 No. 60079-11:2014 CAN/CSA C22.2 No. 60529:2005
	F = Explosionproof / Flame proof	Class I, Division 1, Groups BCD T6...T3 Ex db IIB-1/2 G Ex ia IIC T4 Ga/Gb Ta = -50°C to 71°C IP65	CSA C22.2 No. 0.4-04:R2013 CSA C22.2 No. 0.5:R2012 CSA C22.2 No. 0-10:R2015 CSA C22.2 No. 30:R2012 CAN/CSA C22.2 No. 60079-0:2015 CAN/CSA C22.2 No. 60079-1:2016 CAN/CSA C22.2 No. 60079-26:2016 CAN/CSA C22.2 No. 61010.1:2012 CSA C22.2 No. 60529:R2010
E = ATEX	I = Intrinsic Safety	⊕ II 1/2 G Ex ia IIC T4 Ta = -50°C to 71°C IP65	EN 60079-0:2012 EN 60079-11:2012 EN 60529:1991 + A1:2000
	F = Flame proof	⊕ II 2 G Ex db IIB-1/2 G Ex ia IIC T4 Ga/Gb Ta = -50°C to 71°C IP65	EN 60079-0:2012+A11:2013 EN 60079-1:2014 EN 60079-26:2015 EN 60529:1991 + A2:2013
F = NEC	I = Intrinsic Safety	Class I, Division 1, Groups ABCD T4 Class I, Zone 0/1, AEx ia IIC T4 Ta = -50°C to 71°C IP65	FM 3600:2011 FM 3610:2010 FM 3810:2005 ANSI/ISA 60079-0:2013 ANSI/ISA 60079-11:2014 ANSI/IEC 60529:2004
	F = Explosionproof / Flame proof	Class I, Division 1, Groups ABCD T6...T3 Class I, Division 1, Groups BCD T6...T3 Class I, Zone 0/1, Ex db IIB-1/2 G Ex ia IIC T4 Ga/Gb Ta = -40°C to 71°C IP65	FM 3600:2011 FM 3615:2006 FM 3810:2005 ANSI/ISA 60079-0:2013 ANSI/UL 60079-1:2015 ANSI/UL 60079-26:2017 ANSI/IEC 60529:2004
I = IEC	I = Intrinsic Safety	Ex ia IIC T4 Ga/Gb Ta = -50°C to 71°C IP65	IEC 60079-0:2011 IEC 60079-11:2011
	F = Flame proof	Ex db IIB-1/2 G Ex ia IIC T4 Ga/Gb Ta = -50°C to 71°C IP65	IEC 60079-0:2007-10 IEC 60079-1:2007-04 IEC 60079-26:2014-10 IEC 60529:2013

Table 8: Agency approvals



## 13.2 Certificates

Downloadable copies of all certificates are located at [www.mtssensors.com](http://www.mtssensors.com) and can be downloaded on the product specific landing page. If there is any difficulty in obtaining the certificates from the web contact MTS Technical Support and they will be sent electronically.

## 13.3 FM (NEC)

### 13.3.1 Intrinsically Safe

#### 13.3.1.1 Specific Conditions of Safe Use

1. The apparatus enclosure contains aluminum and is considered to constitute a potential risk of ignition by impact or friction. Care must be taken into account during installation and use to prevent impact or friction. ( When installed in a Ga Approval)
2. The maximum permitted ambient temperature of the Level Plus Digital/Analog Level Transmitter is 71 °C. To avoid the effects of process temperature and other thermal effects care shall be taken to ensure the surrounding ambient and the ambient inside the transmitter housing does not exceed 71°C
3. Some models contain non-metallic enclosure parts, to prevent the risk of electrostatic sparking the nonmetallic surface should only be cleaned with a damp cloth.

#### 13.3.1.2 Labels

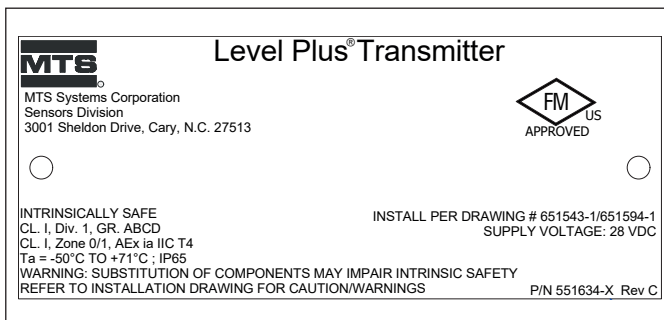
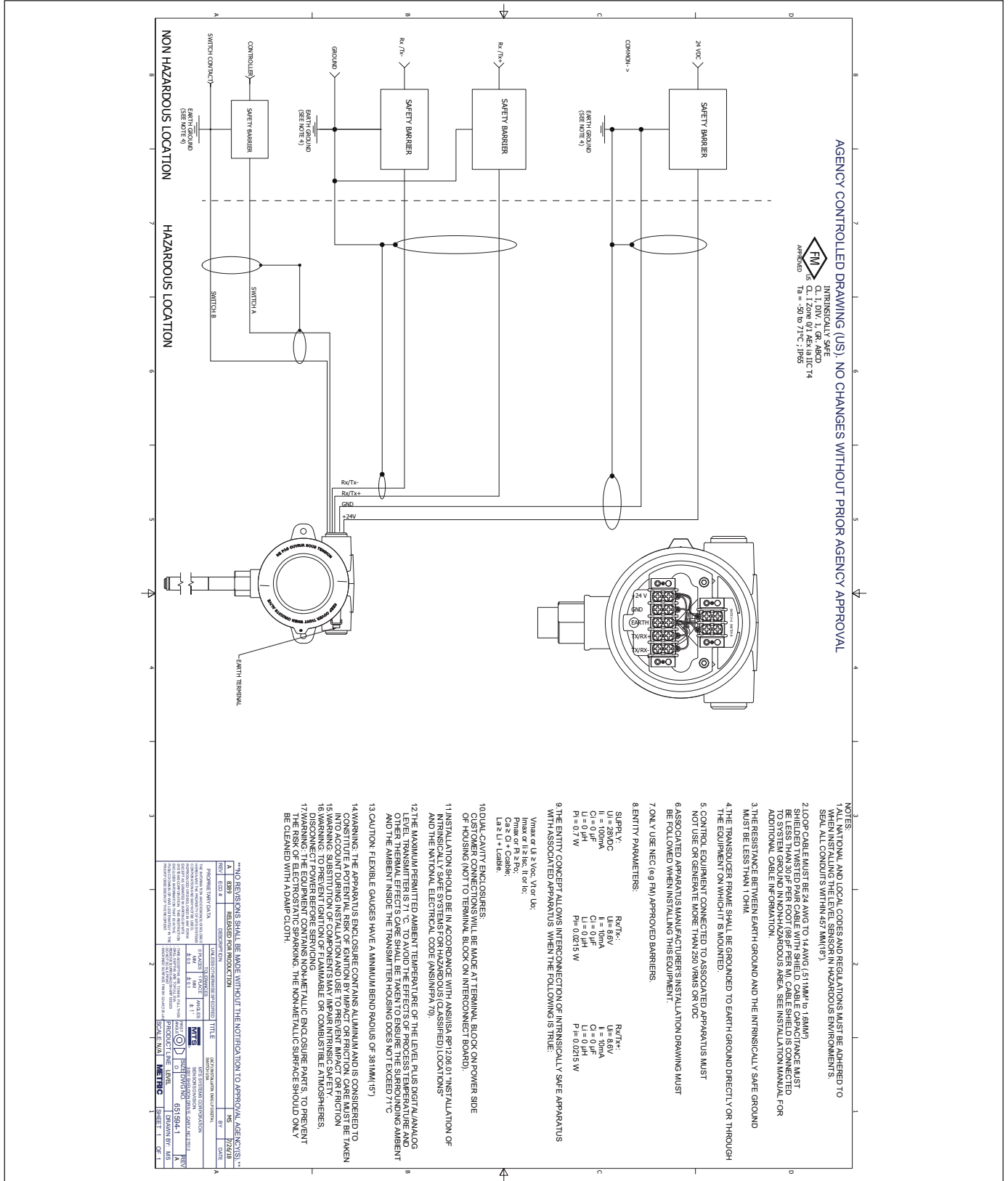

Fig. 14: Intrinsically Safe FM label, Modbus, Dual Cavity Housing

13.3.1.3 Installation drawing



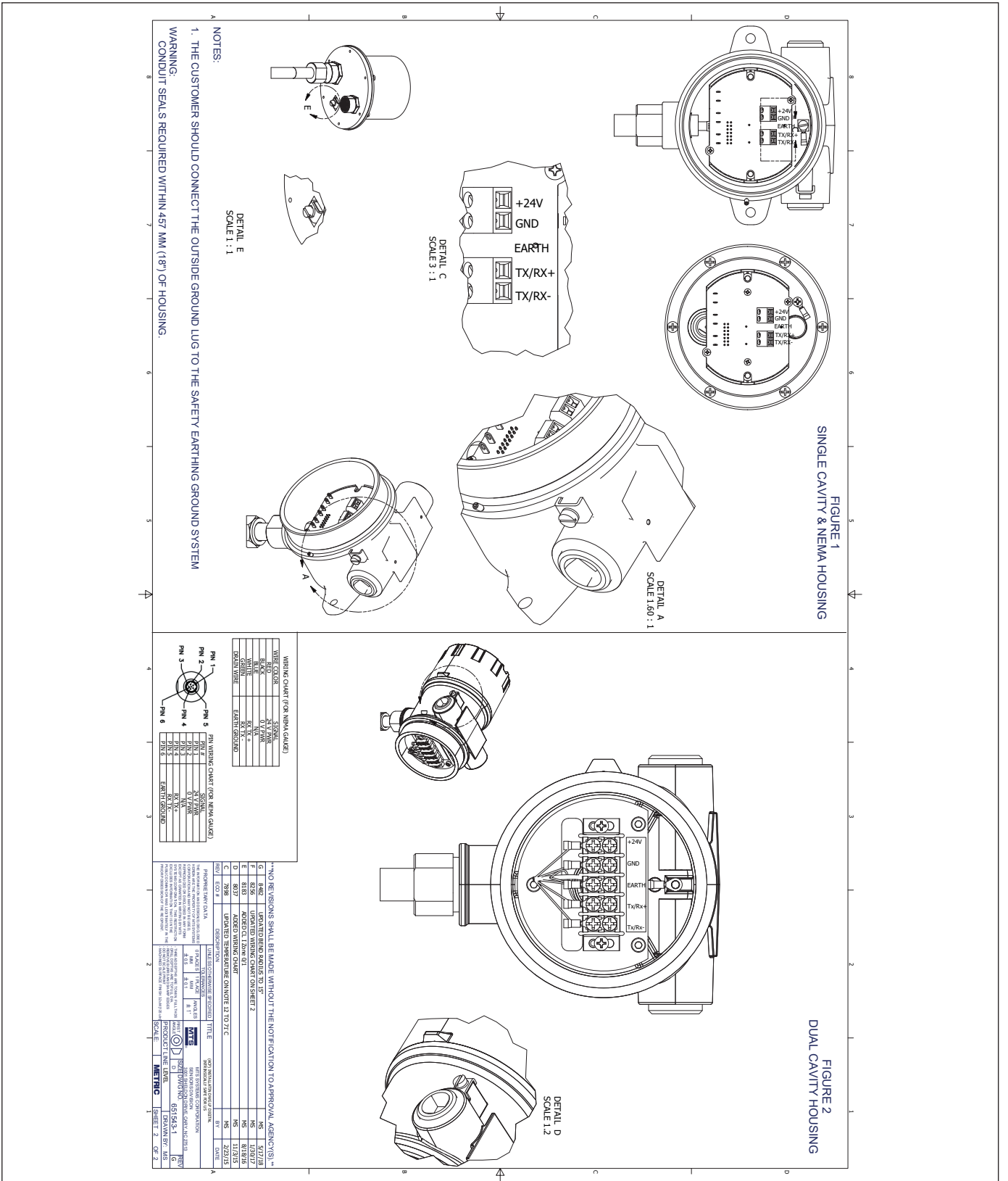

Fig. 16: Intrinsically Safe FM installation drawing, Modbus, Page 2

### 13.3.2 Explosionproof / Flame Proof

#### 13.3.2.1 Specific Conditions of Safe Use

1. Warning: The equipment contains non-metallic enclosure and process parts, to prevent the risk of electrostatic sparking, the non-metallic surface should only be cleaned with a damp cloth. Painted surface of the equipment may store electrostatic charge and become a source of ignition in applications with a low relative humidity <~30% relative humidity where the painted surface is relatively free of surface contamination such as dirt, dust or oil. Cleaning of the painted surface should only be done with a damp cloth.
2. Cables shall be rated > 5°C above maximum ambient temperature.
3. To maintain the ingress protection rating of IP66, T100™ tape (3 wraps) on pipe dope shall be used. Refer to installation instructions.
4. The equipment can be installed in the boundary wall between a Zone 0 area and the less hazardous area, Zone 1. In this configuration, the process connection is installed in Zone 0, while the transmitter housing is installed in Zone 1. Refer to installation instructions.
5. Flexible gauges have a minimum bend radius of 381 mm (15 in.).
6. Flamepaths not for repair.
7. The applicable temperature class, ambient temperature range and process temperature range of the equipment is as follows:
  - T3 with Process Temperature range -40°C to +150°C
  - T4 with Process Temperature range -40°C to +135°C
  - T5 with Process Temperature range -40°C to +100°C
  - T6 with Process Temperature range -40°C to +85°CAmbient Temperature Range is  $-40^{\circ}\text{C} \leq T_a \leq 71^{\circ}\text{C}$
8. When mounting on a MLG (magnetic level gauge) make sure the electronic head and pressure barrier have a minimum spacing of 5 in. See Installation Manual for detail.

## 13.4 FMC (CEC)

### 13.4.1 Intrinsically Safe

#### 13.4.1.1 Specific conditions of safe use

1. The apparatus enclosure contains aluminum and is considered to constitute a potential risk of ignition by impact or friction. Care must be taken into account during installation and use to prevent impact or friction. (When installed in a Ga Approval)
2. The maximum permitted ambient temperature of the Level Plus® Digital/Analog Level Transmitter is 71 °C. To avoid the effects of process temperature and other thermal effects care shall be taken to ensure the surrounding ambient and the ambient inside the transmitter housing does not exceed 71°C.
3. Some models contain non-metallic enclosure parts, to prevent the risk of electrostatic sparking the nonmetallic surface should only be cleaned with a damp cloth.

#### 13.4.1.2 Labels

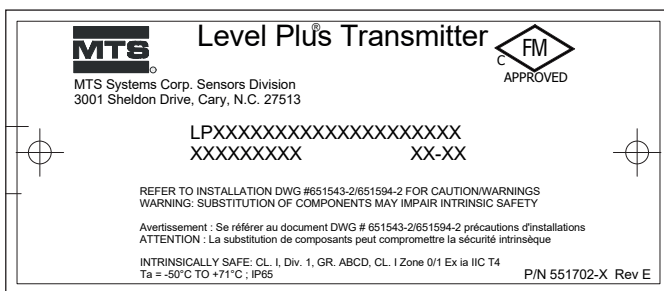

Fig. 17: Intrinsically Safe FMC label, Modbus Dual Cavity Housing





## 13.4.2 Explosionproof / Flame Proof

### 13.4.2.1 Specific Conditions of Safe Use

1. Warning: The equipment contains non-metallic enclosure and process parts, to prevent the risk of electrostatic sparking. The non-metallic surface should only be cleaned with a damp cloth. Painted surface of the equipment may store electrostatic charge and become a source of ignition in applications with a low relative humidity <~30 % relative humidity where the painted surface is relatively free of surface contamination such as dirt, dust or oil. Cleaning of the painted surface should only be done with a damp cloth.
2. Cables shall be rated  $> 5$  °C above maximum ambient temperature.
3. To maintain the ingress protection rating of IP66, Tylon™ tape (3 wraps) on pipe dome shall be used. Refer to installation instructions.
4. The equipment can be installed in the boundary wall between an EPL Ga area and the less hazardous area, EPL Gb. In this configuration, the process connection is installed in EPL Ga, while the transmitter housing is installed in EPL Gb. Refer to installation instructions.
5. Flexible gauges have a minimum bend radius of 381 mm (15 in.).
6. Flamepaths not for repair.
7. The applicable temperature class, ambient temperature range and process temperature range of the equipment is as follows:
  - T3 with Process Temperature range  $-40$  °C to  $+150$  °C
  - T4 with Process Temperature range  $-40$  °C to  $+135$  °C
  - T5 with Process Temperature range  $-40$  °C to  $+100$  °C
  - T6 with Process Temperature range  $-40$  °C to  $+85$  °C
  - Ambient Temperature Range is  $-40$  °C  $\leq$   $T_a$   $\leq$   $71$  °C
8. When mounting on a MLG (magnetic level gauge) make sure the electronic head and pressure barrier have a minimum spacing of 5 in.. See Installation Manual for detail.



## 13.5 ATEX and IECEx

### 13.5.1 Intrinsically Safe

#### 13.5.1.1 Specific conditions of safe use

1. The apparatus enclosure contains aluminum and is considered to constitute a potential risk of ignition by impact or friction. Care must be taken into account during installation and use to prevent impact or friction. (When installed in a Ga Approval)
2. The maximum permitted ambient temperature of the Level Plus® Digital/Analog Level Transmitter is 71 °C. To avoid the effects of process temperature and other thermal effects care shall be taken to ensure the surrounding ambient and the ambient inside the transmitter housing does not exceed 71°C.
3. Some models contain non-metallic enclosure parts, to prevent the risk of electrostatic sparking the nonmetallic surface should only be cleaned with a damp cloth.

#### 13.5.1.2 Labels

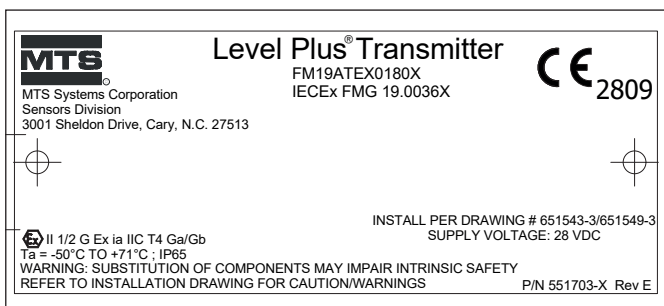

Fig. 20: Intrinsically Safe ATEX/IECEx label, Modbus, Dual Cavity Housing

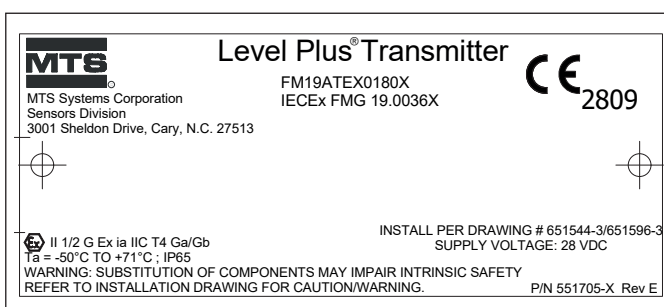

Fig. 21: Intrinsically Safe ATEX/IECEx label, Modbus, Dual Cavity Housing

### 13.5.2 Explosionproof / Flame Proof

#### 13.5.2.1 Specific Conditions of Safe Use

1. Warning: The equipment contains non-metallic enclosure and process parts, to prevent the risk of electrostatic sparking. The non-metallic surface should only be cleaned with a damp cloth. Painted surface of the equipment may store electrostatic charge and become a source of ignition in applications with a low relative humidity <~30% relative humidity where the painted surface is relatively free of surface contamination such as dirt, dust or oil. Cleaning of the painted surface should only be done with a damp cloth.
2. Cables shall be rated  $> 5\text{ }^{\circ}\text{C}$  above maximum ambient temperature.
3. To maintain the ingress protection rating of IP65, Teflon™ tape (3 wraps) on the pipe shall be used. Refer to Installation Instructions.
4. Equipment can be installed in a boundary wall configuration where the process connection is installed as Category 1G equipment while the transmitter housing is installed as Category 2G equipment. Refer to installation instructions.
5. Flexible gauges have a minimum bend radius of 381 mm (15 in.).
6. Flamepaths not for repair.
7. The applicable temperature class, ambient temperature range and process temperature range of the equipment is as follows:
  - T3 with Process Temperature range  $-40\text{ }^{\circ}\text{C}$  to  $+150\text{ }^{\circ}\text{C}$
  - T4 with Process Temperature range  $-40\text{ }^{\circ}\text{C}$  to  $+135\text{ }^{\circ}\text{C}$
  - T5 with Process Temperature range  $-40\text{ }^{\circ}\text{C}$  to  $+100\text{ }^{\circ}\text{C}$
  - T6 with Process Temperature range  $-40\text{ }^{\circ}\text{C}$  to  $+85\text{ }^{\circ}\text{C}$
  - Ambient Temperature Range is  $-40\text{ }^{\circ}\text{C} \leq T_a \leq 71\text{ }^{\circ}\text{C}$
8. When mounting on a MLG (magnetic level gauge) make sure the electronic head and pressure barrier have a minimum spacing of 5 in.. See Installation Manual for detail.

### 13.5.3 EC Declaration of conformity



**SENSORS**  
www.mtssensors.com

EC19.001A

#### EU Declaration of Conformity EU-Konformitätserklärung Déclaration UE de Conformité

**MTS Systems Corporation, Sensors Division, 3001 Sheldon Drive, Cary NC 27513, USA**

declares as manufacturer in sole responsibility that the products  
erklärt als Hersteller in alleiniger Verantwortung, dass die Produkte  
déclare en qualité de fabricant sous sa seule responsabilité que les produits

**Level Plus LPL x\_x\_x\_x\_E\_I\_x\_x\_x\_x\_x\_x\_x\_x\_x\_x\_x\_x\_x\_x\_x\_x (LevelLimit)**

comply with the regulations of the following European Directives:  
den Vorschriften folgender europäischer Richtlinien entsprechen:  
sont conformes aux prescriptions des directives européennes suivantes :

- |                   |   |
|-------------------|---|
| <b>2014/34/EU</b> | Equipment and protective systems for use in potentially explosive atmospheres<br>Geräte und Schutzsysteme zur Verwendung in explosionsgefährdeten Bereichen<br>Appareils et systèmes de protection à être utilisés en atmosphères explosibles   |
| <b>2014/30/EU</b> | Electromagnetic Compatibility<br>Elektromagnetische Verträglichkeit<br>Compatibilité électromagnétique  |
| <b>2011/65/EU</b> | Restriction of the use of hazardous substances in electrical and electronic equipment<br>Beschränkung der Verwendung gefährlicher Stoffe in Elektro- und Elektronikgeräten<br>Limitation de l'utilisation de substances dangereuses dans les équipements électriques et électroniques |

Applied harmonized standards:

Angewandte harmonisierte Normen:  
Normes harmonisées appliquées :

**EN 60079-0:2012+A11:2013, EN 60079-11:2012, EN 60529:1991+A1:2000+A2:2013, EN 61326-1:2013,  
EN 61326-2-3:2013, EN 50581:2012**

EU type examination certificate:

EU-Baumusterprüfbescheinigung:

Certificat de l'examen CE :

issued by / ausgestellt durch / exposé par:

**FM14ATEX0068X Supplement 7**

**FM Approvals Europe Ltd.**

**Dublin, Ireland, One Georges Quay Plaza, D02 E440**

Notified body for quality assurance control:

Benannte Stelle für Qualitätsüberwachung:

Organisme notifié pour l'assurance qualité :

Ident number / Kennnummer / Numéro d'identification :

**FM Approvals Europe Ltd.**

**Dublin, Ireland, One Georges Quay Plaza, D02 E440**

**2809**

Marking/Kennzeichnung / Marquage :

Cary, 2019-11-15

MTS Systems Corporation, Sensors Division, 3001 Sheldon Drive, Cary NC 27513, USA



**II 1/2 G Ex ia IIC T4  
Ta = -40°C to +71°C**

Uwe Viola

Industrial Engineering Manager  
EX Authorized Representative



**UNITED STATES** 3001 Sheldon Drive  
**MTS Systems Corporation** Cary, N.C. 27513  
**Sensors Division** Phone: +1 919 677-0100  
Americas & APAC Region E-mail: info.us@mtssensors.com

**GERMANY** Auf dem Schüffel 9  
**MTS Sensor Technologie** 58513 Lüdenscheid  
**GmbH & Co. KG** Phone: +49 2351 9587-0  
EMEA Region & India E-mail: info.de@mtssensors.com

**ITALY** Phone: +39 030 988 3819  
Branch Office E-mail: info.it@mtssensors.com

**FRANCE** Phone: +33 1 58 4390-28  
Branch Office E-mail: info.fr@mtssensors.com

**UK** Phone: +44 79 44 15 03 00  
Branch Office E-mail: info.uk@mtssensors.com

**SCANDINAVIA** Phone: +46 70 29 91 281  
Branch Office E-mail: info.sca@mtssensors.com

**CHINA** Phone: +86 21 2415 1000 / 2415 1001  
Branch Office E-mail: info.cn@mtssensors.com

**JAPAN** Phone: +81 3 6416 1063  
Branch Office E-mail: info.jp@mtssensors.com

**Document Part Number:**  
551994 Revision A (EN) 01/2020



[www.mtssensors.com](http://www.mtssensors.com)