

# Level Plus<sup>®</sup>

Magnetostrictive Liquid-Level Transmitters  
with Temposonics<sup>®</sup> Technology

## OPERATION AND INSTALLATION MANUAL

M-Series Model MG Digital Transmitter





## UNITED STATES

---

### GENERAL:

Tel: +1-919-677-0100  
Fax: +1-919-677-2343  
E-mail: [info.us@mts.com](mailto:info.us@mts.com)  
<http://www.mtssensors.com>

### MAILING AND SHIPPING ADDRESS:

MTS Systems Corporation  
Sensors Division  
3001 Sheldon Drive  
Cary, North Carolina, 27513, USA

### CUSTOMER SERVICE:

Tel: +1-800-457-6620  
Fax: +1-800-498-4442  
E-mail: [orders@mts.com](mailto:orders@mts.com)

### TECHNICAL SUPPORT AND APPLICATIONS:

24 Hour Emergency Technical Support  
Tel: +1-800-633-7609  
e-mail: [levelplus@mts.com](mailto:levelplus@mts.com)

### OFFICE HOURS (EST):

Monday - Thursday: 8:00 a.m. to 5:00 p.m.  
Friday: 8:00 a.m. to 4:00 p.m.

### REMITTANCE ADDRESS:

MTS Systems Corporation  
Sensors Division  
NW 5872  
P.O. Box 1450  
Minneapolis, MN, 55486-5872

### QUOTE AND CONTRACT TERMS & CONDITIONS:

The parties expressly agree that the purchase and use of Material and/or Services from MTS Sensors Division are subject to MTS' Terms and Conditions, in effect as of the date of this document, which are located at [http://www.mtssensors.com/fileadmin/media/pdfs/Terms\\_and\\_Conditions.pdf](http://www.mtssensors.com/fileadmin/media/pdfs/Terms_and_Conditions.pdf) and are incorporated by reference into this and any ensuing contract. Printed Terms and Conditions can be provided upon request by emailing [info.us@mtssensors.com](mailto:info.us@mtssensors.com) or if you prefer, go to <http://www.mtssensors.com/index> and click the Quote/Contract Terms and Conditions link at the bottom of the page to download the PDF.

## GERMANY

---

### GENERAL:

Tel.: +49-2351-9587-0  
Fax: +49-2351-56491  
e-mail: [info.de@mtssensors.com](mailto:info.de@mtssensors.com)  
<http://www.mtssensor.de>

### MAILING AND SHIPPING ADDRESS:

MTS Sensor Technologie, GmbH & Co. KG  
Auf dem Schüffel 9  
D - 58513 Lüdenscheid, Germany

### TECHNICAL SUPPORT AND APPLICATIONS:

Tel.: +49-2351-9587-0  
e-mail: [info.de@mtssensors.com](mailto:info.de@mtssensors.com)  
<http://www.mtssensor.de>

## JAPAN

---

### GENERAL:

Tel.: +81-42-775-3838  
Fax: +81-42-775-5516  
e-mail: [info.jp@mtssensors.com](mailto:info.jp@mtssensors.com)  
<http://www.mtssensor.co.jp>

### MAILING AND SHIPPING ADDRESS:

MTS Sensors Technology Corporation  
737 Aihara-cho, Machida-shi  
Tokyo 194-0211, Japan

### TECHNICAL SUPPORT AND APPLICATIONS:

Tel.: +81-42-775-3838  
Fax: +81-42-775-5512

## Model MG Operation and Installation Manual

### Reference Information

#### Notices used in this manual

---

This manual contains notices to highlight specific information as follows:

**Notes:**

These notices provide important tips, guidance, or advice.

**Important:**

These notices provide information that might help you avoid inconvenient or problem situations.

**Attention:**

These notices indicate possible damage to programs, devices, or data and is placed just before the instruction or situation in which damage could occur.

**Caution:**

These notices indicate situations that can be potentially hazardous to you. A Caution notice is placed just before a description of a potentially hazardous procedure, step, or situation.

#### Related publications

---

The following publications are listed below by part number followed by description and are available in Adobe Acrobat Portable Document Format (PDF) at <http://www.mtssensors.com/>

- 550784 - Product Specification, Level Plus M-Series Digital
- 551103 - Level Plus Accessories Catalog
- 551104 - Component Replacement Guide
- 550904 - Application Datasheet Rigid
- 550905 - Application Datasheet Sanitary
- 550906 - Application Datasheet 7/8" Flex
- 551410 - Brief Operation Manual for Safe Use
- 550791 (PT) - Operation and Installation Manual, Model MG in Portuguese
- 550791 (KOR) - Operation and Installation Manual, Model MG in Korean

For information about safe work procedures, refer to the following documentation:

- National Electric Code ANSI/NFPA 70
- CSA C22.1 Canadian Electrical Code

#### How this manual is organized

---

- “Introduction”, provides an overview of the manual.
- “Terms and Definitions”, provides definitions of terms used in this manual.
- “Product Overview”, gives an overall product description for the Level Plus liquid-level transmitter, its specifications, use, output, and electronics.
- “Installation and Mounting”, provides detailed installation and mounting information.
- “Electrical Connections and Wiring Procedures”, provides engineering specifications and wiring diagrams to assist in the installation process.
- “Maintenance and Field Service”, provides guidelines for general maintenance and procedures for replacing the Model MG electronic module or level transmitter.
- “Troubleshooting”, provides a list of symptoms, their possible cause and the action to be taken when troubleshooting the transmitter.
- “Quick Start-Up Guide, (Modbus and DDA)”, provides a list of steps to quickly set up your Modbus or DDA output.
- “Modbus Interface”, provides information to communicate via the Modbus RTU protocol.
- “FOUNDATION™ fieldbus Interface”, provides information to communicate via the FOUNDATION™ fieldbus protocol.
- “DDA Protocol”, provides the DDA hardware and software environment overviews.
- “Agency Information” provides comprehensive listings of agency approvals and standards, installation drawings, labels and applicable protocols.

#### Getting information, help, and service

---

You can get the latest ordering information and software updates by visiting [www.mtssensors.com](http://www.mtssensors.com) website. General contact information, shipping and office hours are available on page i.

**Contact information**

General ..... i  
 Mailing and shipping address ..... i  
 Customer service ..... i  
 Technical support and applications ..... i  
 Office hours ..... i  
 Remittance address ..... i  
 Quote and contract terms and conditions ..... i

**Reference information**

Notices used in this manual ..... ii  
 Related publications ..... ii  
 How this manual is organized ..... ii  
 Getting information, help, and service ..... ii

**Introduction**

**Introduction** ..... 1  
**Public website support portal** ..... 1

**Terms and Definitions**

**Terms and definitions reference** ..... 2

**Model MG product overview**

**Product overview** ..... 4  
 Industries ..... 4  
 Applications ..... 4  
 Features ..... 4  
**Components** ..... 4  
 Housings ..... 4  
 Outer pipe configurations ..... 5  
 Floats ..... 6  
 Internal electronics ..... 6  
 Accessories ..... 6  
**Theory of operation** ..... 7  
**Accuracy** ..... 7  
**Warranty** ..... 7  
**Model number identification** ..... 8  
 FM/CSA ..... 8  
 ATEX/IECEX ..... 9  
**Product specifications** ..... 11

**Model MG transmitter installation and mounting**

**Installation and mounting** ..... 12  
**Storage** ..... 12  
**Stilling wells and guide poles** ..... 12  
**Installation** ..... 12  
 Rigid probe ..... 12  
 Flexible probe ..... 13  
**Mounting** ..... 14  
 Threaded flange mounting ..... 14  
 Welded flange mounting ..... 14  
 Sanitary Tri-Clamp mounting ..... 15

**Electrical connections and wiring**

**Electrical connections and wiring procedures** ..... 16  
**Safety recommendations for installation** ..... 16  
**Industrial topologies** ..... 16  
 Point-to-point ..... 16  
 Bus with spurs ..... 16

Tree ..... 16  
 Daisy chain ..... 16  
**Recommended cable types** ..... 17  
 Cable recommendation for Modbus and DDA ..... 17  
 Cable recommendation for FOUNDATION™ fieldbus ..... 17  
**Electrical conduit installation** ..... 17  
**Grounding** ..... 18  
**Safety barriers** ..... 18

**Maintenance and field service**

**Maintenance and field service** ..... 19  
**General maintenance and field service requirements** ..... 19  
 Float maintenance ..... 19  
 Field service ..... 19  
 Service / RMA policy ..... 19

**Troubleshooting**

**Troubleshooting procedures** ..... 20

**Software installation and user interface references**

**Quick start-up guide (Modbus and DDA)** ..... 21  
 Before you begin ..... 21  
 Quick start-up procedure ..... 21

**Modbus user interface**

**Modbus interface** ..... 22  
 Modbus implementation ..... 22  
 Modbus function codes ..... 22  
 Device Modbus register maps ..... 23  
 Special/Advanced diagnostic register maps ..... 27  
 How units are used ..... 27  
 Modbus register Map note references ..... 27

**Formulas used in volume calculation** ..... 31  
**Installing the M-Series digital setup software** ..... 32  
**Setting up and calibrating the Model MG digital transmitter** ..... 33  
 Data from Device tab ..... 33  
 Volume Calculations tab ..... 35

**FOUNDATION™ fieldbus user interface**

**FOUNDATION™ fieldbus interface** ..... 37  
**Device description** ..... 37  
**Transducer block** ..... 37  
**Analog input function blocks** ..... 40  
**Resource block** ..... 41  
**LAS/Back-up LAS** ..... 41  
**Setup and calibration** ..... 41  
**FOUNDATION™ fieldbus handheld menu tree** ..... 42

**DDA user interface**

**DDA interface** ..... 43  
**Hardware and software environments** ..... 43  
**DDA command decoder examples** ..... 44  
**DDA/Host computer communication protocol** ..... 44  
 Network protocol/timing considerations ..... 46

**DDA user interface (Continued)**

**DDA command definitions**  
**(includes protocol information) ..... 47**  
 Special control commands ..... 47  
 Level commands ..... 48  
 Temperature commands ..... 48  
 Multiple output commands ..... 49  
 High-level memory read commands ..... 50  
 High-level memory writing commands ..... 51  
 Diagnostic/Special command set ..... 53  
 DDA Error codes ..... 53

**M-Series digital setup software installation, setup and calibration ..... 54**  
 Data from device tab ..... 54

**Agency Information**

**Agency approvals ..... 56**  
**FM/CSA ..... 56**  
**ATEX ..... 56**  
**CCoE ..... 56**  
**KC ..... 56**  
**IECEX ..... 57**  
**INMETRO ..... 57**  
**NEPSI ..... 57**  
**IP/NEMA Rating ..... 57**

**Hazardous area installation ..... 58**  
 FM/CSA for Modbus and DDA ..... 58  
     Installation drawings ..... 59  
     Notes ..... 59  
     Wiring connections ..... 60  
 ATEX and IECEX for Modbus and DDA ..... 62  
     Installation drawings ..... 63  
     Notes ..... 64  
     Wiring connections ..... 65  
     Special Condition for Use ..... 67  
 FM/CSA for FOUNDATION™ fieldbus ..... 68  
     Installation drawing ..... 69  
     Notes ..... 69  
     Wiring connections ..... 69  
 ATEX and IECEX for FOUNDATION™ fieldbus ..... 72  
     Installation drawing ..... 73  
     Notes ..... 74  
     Wiring connections ..... 74  
     Special Condition for Use ..... 75

**ATEX certificates ..... 76**  
**CSA certificate ..... 82**  
**FM certificate ..... 84**  
**NEPSI certificates ..... 88**  
**IECEX certificates ..... 94**  
**EC Declaration of Conformity ..... 97**  
**CCoE certificates ..... 99**  
**ABS Type Approval ..... 101**

## Introduction

---

MTS is recognized as the pioneer, innovator and leader in magnetostrictive sensing. The new Level Plus® M-Series transmitter design represents a continuation of our on-going effort to provide effective, innovative and reliable products to the Liquid Level marketplace.

This manual will provide the following information about the Level Plus Model MG digital transmitter:

- Terms and definitions
- Product overview
- Installation and mounting
- Electrical connections and wiring procedures
- Maintenance and field service
- Troubleshooting
- Quick start-up guide (Modbus and DDA)
- Modbus interface
- FOUNDATION™ fieldbus interface
- DDA interface
- Product certification

## Public website support portal

---

Visit our support portal at <http://www.mtssensors.com> for:

- Building Level Plus M-Series model numbers
- Latest documentation releases
- Detailed ordering information
- Latest software updates

Terms and definitions reference

**6A Heavy Oils** – ‘Generalized Crude Oils’, Correction of Volume to 60 °F against API Gravity.

**6B Light Oils** – ‘Generalized Products’, Correction of Volume to 60 °F against API Gravity.

**6C Chemical** – ‘Volume Correction Factors (VCF)’ for individual and special applications, volume correction to 60 °F against thermal expansion coefficients.

**6C Mod** – An adjustable temperature reference for defining *VCF*.

**A**

**API Gravity** – The measure of how heavy or light a petroleum liquid is compared to water. Allowable values are 0 to 100 degrees *API* for (6A) and 0 to 85 degrees *API* for (6B).

**D**

**DDA** – ‘Direct Digital Access’ – The proprietary digital protocol developed by MTS for use in intrinsically safe areas.

**Density** – Mass divided by the volume of an object at a specific temperature. The density value should be entered as lb / cu. ft..

**E**

**Explosion-proof** – Type of protection based on enclosure in which the parts which can ignite an explosive gas atmosphere are placed within and which can withstand the pressure developed during an internal explosion of an explosive mixture, and which prevents the transmission of the explosion to the explosive gas atmosphere surrounding the enclosure.

**F**

**Flameproof** – Type of protection based on enclosure in which the parts which can ignite an explosive gas atmosphere are placed within and which can withstand the pressure developed during an internal explosion of an explosive mixture, and which prevents the transmission of the explosion to the explosive gas atmosphere surrounding the enclosure.

**FOUNDATION™ fieldbus** – An all digital, serial, two-way communications system that serves as the base-level network in a plant or factory automation environment. Developed and administered by the fieldbus FOUNDATION™.

**G**

**GOVI** – ‘Gross Observed Volume of the Interface’ – The total volume of the tank occupied by the interface liquid. The *GOVI* is only given when measuring two liquids and is calculated by subtracting the volume of the product from the total volume of liquid in the tank ( $GOVT - GOVP$ ).

**GOVP** – ‘Gross Observed Volume of the Product’ – The total volume of the tank occupied by the product liquid. When measuring only one liquid, it is also the total volume of liquid in the tank (*GOVT*). When measuring two liquids it is the total volume of liquid in the tank minus the volume of the interface liquid ( $GOVT - GOVI$ ).

**GOVT** – ‘Total Gross Observed Volume’ – The total volume of liquid in the tank. When measuring only one liquid it is equal to the volume of the product (*GOVP*). When measuring two liquids it is equal to the volume of the product and interface liquids ( $GOVP + GOVI$ ).

**GOVU** – ‘Gross Observed Volume Ullage’ – the difference in volume between the working capacity of a tank and the total volume in the tank ( $Working\ Capacity - GOVT$ ).

**I**

**Interface** – *Noun*; The measurement of the level of one liquid when that liquid is below another liquid.

**Interface** – *Adj.*; The *Software Graphical User Interface (GUI)* that allows the user to access software protocols (*DDA, MODBUS*).

**Intrinsic safety** – ‘Intrinsically safe’ - Type of protection based on the restriction of electrical energy within apparatus of interconnecting wiring exposed to potentially explosive atmosphere to a level below that which can cause ignition by either sparking or heating effects.

**M**

**Mass** – The property of a body that causes it to have weight in a gravitational field, calculated by density at the reference temperature multiplied by the volume correction factor ( $Density * VCF$ ).

**MODBUS** – A *serial communications protocol* published by Modicon in 1979 for use with its programmable logic controllers (PLCs). It has become a de facto standard communications protocol in industry, and is now the most commonly available means of connecting industrial electronic devices.

**N**

**NEMA Type 4X** – A product *Enclosure* intended for indoor or outdoor use primarily to provide a degree of protection against corrosion, windblown dust and rain, splashing water, and hose-directed water; and to be undamaged by the formation of ice on the enclosure. They are not intended to provide protection against conditions such as internal condensation or internal icing.

**NPT** – *U.S. standard* defining tapered pipe threads used to join pipes and fittings.

**NSVP** – ‘Net Standard Volume of the Product’ – The temperature corrected volume for the product liquid in the tank, requires the transmitter to be ordered with temperature measurement capabilities. The *NSVP* is calculated by multiplying the volume of the product liquid by a volume correction factor based on temperature ( $GOVP * VCF$ ).

**R**

**Reference Temperature** – The *temperature* at which the density measurement is given, the allowable values are 32 °F to 150 °F.

**S**

**Specific Gravity** – The *density ratio* of a liquid to the density of water at the same conditions.

**Sphere Radius** – The *internal radius* of the sphere that contains the liquid, the value is used to calculate the volume along with the *Sphere Offset*.

**Sphere Offset** – An *offset value* that accounts for additional volume in a sphere from non-uniform sphere geometry, the value is used to calculate the volume along with the *Sphere Radius*.

**Strap Table** – A *table of measurement* correlating the height of a vessel to the volume that is contained at that height. The transmitter can contain up to 100 points.

## T

---

**TEC** – ‘Thermal Expansion Coefficient’ - a value correlating the change in temperature for an object with the change in its volume. Allowable values are 270.0 to 930.0. TEC units are in 10 E-6/Deg F.

**Temperature Correction Method** – One of five *product correction methods* used to correct the product volume in the tank due to changes in temperature from 60 °F including (6A, 6B, 6C, 6C Mod, and Custom Table).

## V

---

**Volume Calculation Mode** – One of two methods use to calculate volume measurements from level measurements, including *Sphere* and *Strap Table*.

**VCF** – ‘Volume Correction Factor’ – A table of measurements correlating temperature points with correction factors for the liquids expansion/contraction. The transmitter can contain up to 50 points.

## W

---

**Working Capacity** – *The maximum volume of liquid* that the user desires for their vessel to hold, typically 80% of the vessels maximum volume before overflow.

## Model MG Operation and Installation Manual

### Product Overview

### Product overview

The Level Plus Model MG Liquid-Level transmitter is a continuous multi-functional magnetostrictive transmitter that provides product level, interface level, and temperature to the user via Modbus, DDA, or FOUNDATION™ fieldbus output. Magnetostrictive technology is one of the most accurate and repeatable level technologies available to date. MTS is the inventor and purveyor of magnetostrictive technology and has been serving the level industry for over 35 years.

#### INDUSTRIES

- Petroleum
- Liquid petroleum gas
- Pharmaceutical
- Food & beverage
- Chemical
- Wastewater
- Mining

#### APPLICATIONS

- Tank farms
- Terminals
- Bullet tanks
- Spheres
- Separator tanks
- Battery tanks
- Storage tanks

#### FEATURES

- 3-in-1 measurement
  - Product level
  - Interface level
  - Temperature level
- 100 Point strap table
- No scheduled maintenance or recalibration
- API temperature corrected volumes
- Non-linearity  $\pm 1$  mm
- Field repairable

### Components

The Level Plus Model MG liquid level transmitter consists of four main components; a housing, outer pipe, float, and electronics. Varying the components of the transmitter allows the transmitter to be customized to almost any application.

#### HOUSINGS

Level Plus Model MG transmitters are available in three housing configurations; NEMA Type 4X 316L stainless steel, explosion-proof single and dual-cavity housings as shown below:



NEMA Type 4X 316L stainless-steel housing

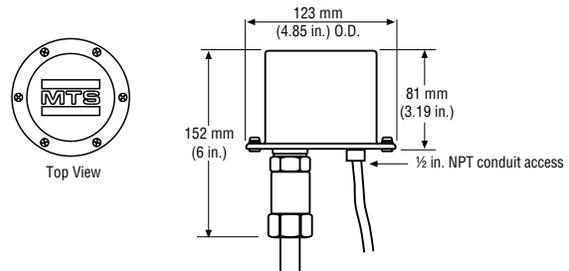

Single cavity explosion-proof housing

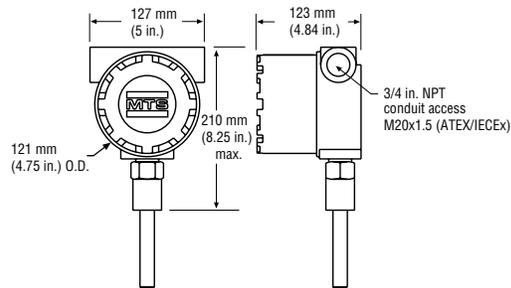

Dual cavity explosion-proof housing

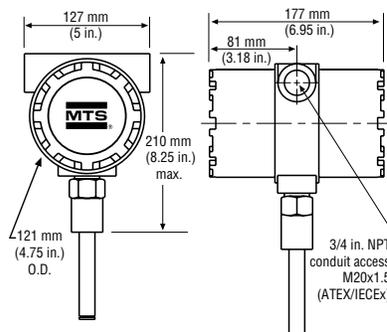

**OUTER PIPE CONFIGURATIONS**

The outer pipe is constructed of a variety of configurations, shown below. Contact factory for other materials (such as Hastelloy C or Teflon).

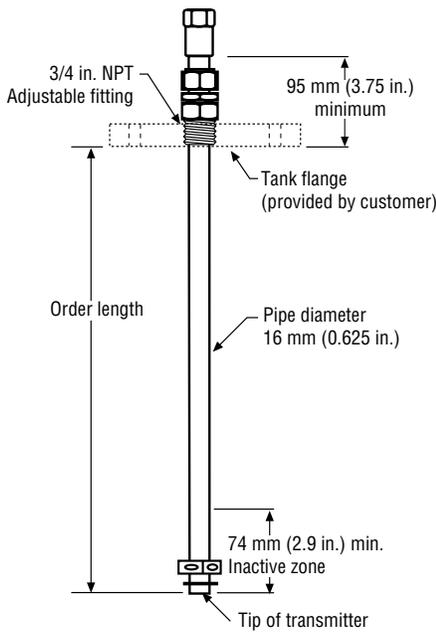

**Figure 1** 5/8 in. diameter rigid outer pipe of 316L stainless steel

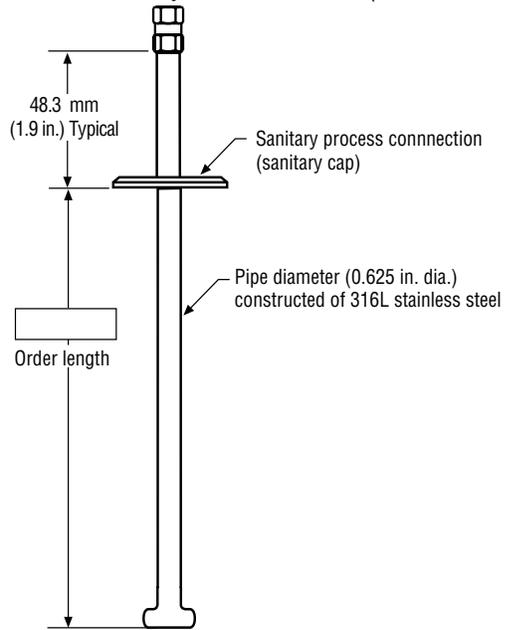

**Figure 2** 5/8 in. diameter rigid outer pipe of polished 316L stainless steel with sanitary process connection and end plug

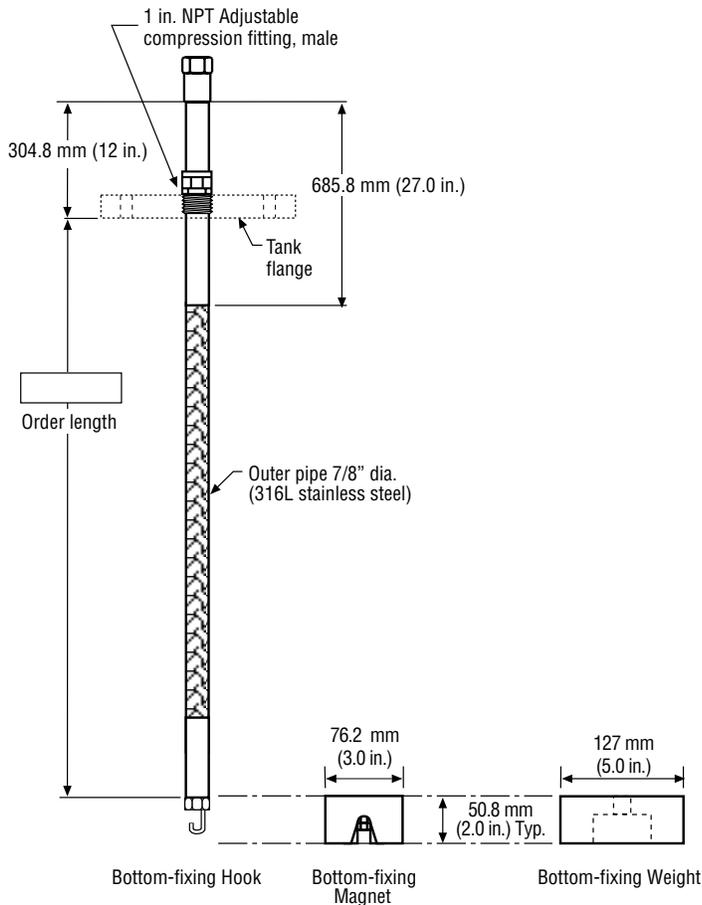

**Figure 3** 7/8 in. diameter flexible pipe of 316L stainless steel

**FLOATS**

Model MG transmitters offer numerous floats for different applications such as stainless steel, 3-A sanitary, hastelloy, Teflon, and Nitrophyl for both product level and interface level. To be able to accurately detect the interface level there needs to be a difference of at least 0.05 in specific gravities between the product and interface liquids. For detailed information about floats, refer to the ‘Accessories Catalog’, MTS part number 551103.

For assistance with selecting a specific float for your application, please contact *Technical Support* with the following information:

- Specific gravity of liquid(s) being measured
- Process temperature
- Process Opening Size
- Vessel pressure

For ATEX, IECEx, and CCoE approvals, Model MG transmitters should be used with a float having an offset weight and made of stainless steel or Hastelloy C. This allows the float to stay in contact with the pipe to prevent the buildup of an electrostatic charge. For detailed information about floats, refer to the ‘Accessories Catalog’, MTS part number 551103.

Non-metallic floats with a projected surface area of less than 5,000 mm<sup>2</sup> should only be used in Zone 0, Gas group IIA such as float part numbers 201643-2, 201649-2, 201650-2, 201109, 251115 and 251116. All other non-metallic floats offered by MTS such as, 251939, 251119, 251120 and 252999, should not be used in a hazardous area application.

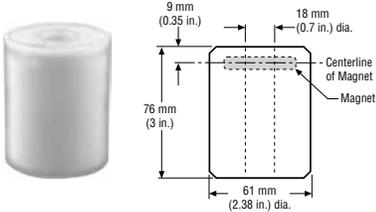
NITROPHYL FLOATS Float and dimension reference	Projected surface area	Part number
	2356 mm <sup>2</sup>	201643-2
		201649-2
		201650-2
TEFLON FLOATS Float and dimension reference	Projected surface area	Part number
	4635 mm <sup>2</sup>	201109
		251115
		251116

**INTERNAL ELECTRONICS**

All transmitters come with two electronic components of a sensing element and a board set. All sensing elements up to 300 inches (7620 mm) are rigid and greater lengths have flexible sensing elements. Flexible sensing elements are only available under 300 inches (7620 mm) as special orders. The board set consists of a top board and bottom board that differ depending on the output. A temperature sensing function is optional with the Model MG transmitter. The temperature sensing device is a digital thermometer (DT) mounted inside the transmitter’s pipe assembly. The DT is capable of an inherent accuracy of ± 0.5 °F (0.28 °C).

**ACCESSORIES**

MTS also offers a series of displays, housings, converters, and other accessories, please refer to the ‘Accessories Catalog’, MTS part number 551103.

## Theory of operation

Magnetostrictive M-Series transmitters precisely sense the position of an external float by applying an interrogation pulse to a waveguide medium. This current pulse causes a magnetic field to instantly surround the waveguide. The magnet installed within the float also creates a magnetic field. Where the magnetic fields from the waveguide and float intersect, a rotational force is created (waveguide twist). This, in turn, creates a torsional-sonic pulse that travels along the waveguide as shown in *Figure 4*.

The head of the transmitter houses the sensing circuit, which detects the torsional-sonic pulse and converts it to an electrical pulse. The distance from a reference point to the float is determined by measuring the time interval between the initiating current pulse and the return pulse and precisely knowing the speed of these pulses. The time interval is converted into a level measurement.

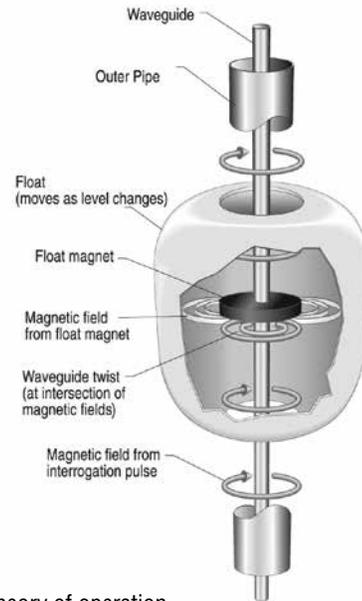

**Figure 4** Theory of operation

## Accuracy

For magnetostrictive transmitters inherent accuracy is measured in terms of non-linearity. Non-linearity is a measurement of any imperfections in the waveguide that are reflected in the linearity of the transmitter's output. MTS tolerances reflect a maximum non-

linearity of  $\pm 1$  mm (0.039 in.). MTS is able to achieve such strict tolerances by manufacturing all of its own waveguide from a proprietary alloy and testing 100% of all transmitters before shipping.

## Warranty

### Important:

Contact Technical Support or Customer Service for assistance if you suspect that the transmitter is not working correctly. Technical support can assist you with troubleshooting, part replacement, and *Returned Material Authorization* (RMA) information if required.

All M-Series transmitters come with a two year limited warranty from the factory shipment date. A *Return Materials Authorization* (RMA) number is required and must accompany any transmitter returns. Any unit that was used in a process must be properly cleaned in accordance with OSHA standards, before it is returned to the factory. A *Material Safety Data Sheet* (MSDS) must also accompany the transmitter that was used in any process.



## Model number identification for ATEX and IECEx based approval

<b>TRANSMITTER MODEL</b>			=	<b>M</b>	1
<b>M</b>	= Magnetostrictive transmitter				
<b>TYPE</b>			=	<b>G</b>	2
<b>G</b>	= Digital output level transmitter				
<b>APPROVAL AGENCY</b>			=		3
<b>E</b>	= ATEX approved	<b>P</b>	= CCoE approved	<b>B</b>	= INMETRO
<b>H</b>	= IECEx approved	<b>K</b>	= KC approved		
<b>OUTPUT</b>			=		4
<b>M</b>	= Modbus RTU data format	<b>F</b>	= FOUNDATION™ fieldbus (Flameproof Only)		
<b>D</b>	= MTS DDA				
<b>HOUSING TYPE</b>			=		5
<b>B</b>	= Single Cavity (Flameproof IIB)	<b>R</b>	= Single Cavity (ATEX, EEx ia IIB)		
<b>C</b>	= Dual Cavity (Flameproof IIB)	<b>S</b>	= Dual Cavity (ATEX, EEx ia IIB)		
<b>F</b>	= NEMA 4X, 316L SS with cable (ATEX, EEx ia IIA)		<b>4</b>	= NEMA 4X, 316L SS with terminal block (ATEX, EEx ia IIA)	
<b>G</b>	= Single Cavity (ATEX, EEx ia IIA)		<b>5</b>	= NEMA 4X, 316L SS with terminal block (ATEX, EEx ia IIB)	
<b>H</b>	= Dual Cavity (ATEX, EEx ia IIA)				
<b>P</b>	= NEMA 4X, 316L SS with cable (ATEX, EEx IIB)				
<b>ELECTRONICS MOUNTING</b>			=		6
<b>1</b>	= Integral electronics				
<b>TRANSMITTER PIPE/HOSE</b>			=		7
<b>B</b>	= Industrial end-plug with stop collar	<b>M</b>	= Flexible w/bottom fixing hook (stainless steel only)		
<b>C</b>	= Sanitary, T-bar, TB	<b>N</b>	= Flexible w/bottom fixing weight (stainless steel only)		
<b>D</b>	= Sanitary, drain-in-place, DP	<b>P</b>	= Flexible w/bottom fixing magnet (stainless steel only)		
<b>E</b>	= Sanitary, clean-in-place, CP	<b>L</b>	= Sanitary Special		
<b>F</b>	= Sanitary, drain-in-place, no hole, DN				
<b>MATERIALS OF CONSTRUCTION (WETTED PARTS) (Note: contact factory for other materials)</b>			=		8
<b>1</b>	= Stainless steel, 1,4404		<b>A</b>	= Teflon / FEP	
<b>2</b>	= Stainless steel, 1,4404 electropolished (3A approved, Ra 15 finish)				
<b>3</b>	= Hastelloy C				
<b>PROCESS CONNECTION TYPE</b>			=		9
<b>1</b>	= NPT, adjustable fitting		<b>7</b>	= 300 lb. welded RF flange	
<b>4</b>	= Sanitary, welded		<b>8</b>	= 600 lb. welded RF flange	
<b>5</b>	= Sanitary, adjustable fitting		<b>9</b>	= DIN flange welded according to specification	
<b>6</b>	= 150 lb. welded RF flange				
<b>PROCESS CONNECTION SIZE</b>			=		10
<b>A</b>	= ¾ in. (NPT for 5/8 in. pipe)		<b>F</b>	= 3 in.	
<b>B</b>	= 1 in. (NPT for 7/8 in. hose)		<b>G</b>	= 4 in.	
<b>C</b>	= 1½ in.		<b>H</b>	= 5 in. (except sanitary)	
<b>D</b>	= 2 in.		<b>J</b>	= 6 in.	
<b>E</b>	= 2½ in.				



Product specifications

Parameters	Specifications
<b>LEVEL OUTPUT</b>	
<b>Measured variable:</b>	Product level and interface level
<b>Output signal / Protocol:</b>	Modbus RTU, DDA or FOUNDATION™ fieldbus
<b>Order length:</b>	<p><b>Flexible hose:</b> (ATEX EEx ia IIB): 3048 mm (120 in.) to 13500 mm (531.5 in.) (All Else): 3048 mm (120 in.) to 22000 mm (866 in.) Δ § Δ §</p> <p><b>Rigid pipe:</b> 508 mm (20 in.) to 7620 mm (300 in.) Δ § <b>Sanitary pipe:</b> 508 mm (20 in.) to 7620 mm (300 in.) Δ §</p> <p>Δ Contact factory for longer lengths. § Order length equals the measurement range plus the inactive zone.</p>
<b>Inherent accuracy:</b>	±1 mm (0.039 in.)
<b>Hysteresis:</b>	0.002% F.S. or 0.397 mm (1/64 in.)* (any direction) * Whichever is greater
<b>Resolution:</b>	0.025 mm (0.001 in.)
<b>Calculated variables:</b>	GOVP GOVI GOVT GOVU NSVP

<b>TEMPERATURE OUTPUT</b>	
<b>Measured variable:</b>	Average and multi-point temperatures Up to 12 Modbus ∞ Up to 5, DDA and FOUNDATION™ fieldbus ∞ Minimum length of 2032 mm (80 in.) for 12 temperature positions.
<b>Temperature accuracy:</b>	±0.2 °C (0.4 °F) range -40 °C (-40 °F) to -20 °C (-4 °F)*, ±0.1 °C (0.2 °F) range -20 °C (-4 °F) to 70 °C (158 °F)*, ±0.15 °C (0.3 °F) range 70 °C (158 °F) to 100 °C (212 °F)*, ±0.5 °C (0.9 °F) range 100 °C (212 °F) to 125 °C (257 °F)*, * For models MGA, MGE, and MGH. All other models ±0.28 °C (0.5 °F)

<b>ELECTRONICS</b>	
<b>Input voltage:</b>	<b>Modbus and DDA:</b> 10.5 to 30.1 Vdc 28 Vdc maximum for I.S. approval <b>FOUNDATION™ fieldbus:</b> 9 to 32 Vdc bus powered
<b>Fail safe:</b>	High, full scale
<b>Reverse polarity protection:</b>	Series diode

Parameters	Specifications
<b>Lightning/Transient protection:</b>	<b>Stage 1:</b> Line-to-ground surge suppression; IEC 61000-4-5 <b>Stage 2:</b> Line-to-line and line-to-ground transient suppressors; IEC 61000-4-4

<b>CALIBRATION</b>	
<b>Zero adjust range:</b>	Anywhere within the active length
<b>Span adjust range:</b>	Full scale to 152 mm (6 in.) from zero

<b>ENVIRONMENTAL</b>	
<b>Enclosure rating:</b>	NEMA Type 4X
<b>Humidity:</b>	0 to 100% relative humidity, non-condensing
<b>Operating temperatures:</b>	<b>Electronics*:</b> -40 °C (-40 °F) to 71 °C (160 °F) <b>Sensing element:</b> -40 °C (-40 °F) to 125 °C (257 °F) ◇ <b>Temperature element:</b> -40 °C (-40 °F) to 105 °C (221 °F) ◇ Contact factory for specific temperature ranges. * Consult Agency Approvals section for approval specific ambient temperature rating.
<b>Vessel pressure:</b>	<b>Industrial Rigid Pipe:</b> 1000 psi (70 bar) <b>Sanitary Pipe:</b> 435 psi (30 bar) <b>Teflon Pipe:</b> 100 psi (7 bar) <b>Flexible Hose:</b> 260 psi (18 bar)
<b>Materials:</b>	<b>Wetted parts:</b> 316L stainless steel † <b>Non-wetted parts:</b> 316L stainless steel, Epoxy coated aluminum † Contact factory for alternative materials.

<b>FIELD INSTALLATION</b>	
<b>Housing dimensions:</b>	<b>Single cavity:</b> 127 mm (5 in.) by 123 mm (4.85 in.) 121 mm (4.75 in.) O.D. <b>Dual cavity:</b> 127 mm (5 in.) by 177 mm (6.95 in.) 121 mm (4.75 in.) O.D. <b>NEMA Type 4X:</b> 81 mm (3.2 in.) by 123 mm (4.85 in.) O.D.
<b>Mounting:</b>	<b>Rigid pipe:</b> ¾ in. Adjustable MNPT fitting, Flange and Tri-Clamp® Mounts <b>Flexible hose:</b> 1 in. Adjustable MNPT fitting, Flange mount
<b>Wiring:</b>	<b>Modbus and DDA:</b> 4-wire connections plus earth ground. Daniel Woodhead 6-pin male connector. Integral cable with pigtailed. <b>FOUNDATION™ fieldbus:</b> Type A fieldbus cable

<b>ELECTRICAL CONNECTIONS</b>	
<b>Single and Dual Cavity:</b>	¾ in. FNPT conduit opening, M20 for ATEX/IECEX/CCoE version
<b>NEMA Type 4X:</b>	½ in. FNPT conduit opening

Product Overview

## Installation and mounting

If the installation is going to occur in a hazardous area, completely read the Agency Information section before starting any work. The Agency Information outlines additional regulations that need to be followed in order for the installation to comply with hazardous area regulations.

This section contains information about storing your transmitter (prior to installation) and detailed procedures for installing and mounting your transmitter.

### Storage

If storage is required prior to installation, store indoors in a dry environment at ambient temperature range not exceeding -40 °C (-40 °F) to 71 °C (160 °F).

### Stilling wells and guide poles

Level Plus transmitters can be mounted in slotted or un-slotted stilling wells but a slotted stilling well is always preferred. Using a un-slotted stilling well will negatively affect performance of any level device as the level in the stilling well will differ from the level in the tank. The Level Plus transmitter can also be installed to one side of the stilling well to also allow for sampling and manual gauging from the same opening as the automatic tank gauging. Contact *Technical Support* for details.

Level Plus transmitters do not require a stilling well for installation. Our transmitters are installed in numerous tanks without stilling wells with no loss in performance due to our patented flexible waveguide and hose. A stilling well is highly recommended for agitated, turbulent, and/or fast filling tanks.

### Installation

The installation procedures below are illustrated using the adjustable NPT fitting for a threaded flange mount. The procedures will have to be slightly adjusted if using a welded flange or sanitary tri-clamp mount.

#### RIGID PROBE

##### Tools Required:

- Channel lock pliers
- Common screwdriver
- 5/32 in. Hex key (allen wrench)

##### Caution:

It is recommended that assembly and mounting of this transmitter should not be performed alone. To ensure proper and safe assembly of the M-Series transmitter, a minimum of two (2) individuals are recommended. Gloves are also recommended. In addition, PPE is required for work areas such as safety shoes, safety glasses, hard hat, and fire resistant clothing.

Perform the following steps to Install the Model MG Digital transmitter:

1. Remove the stop collar and E-ring. With assistance, feed the rigid pipe through the hole of the removed tank flange until the flange is positioned near the top of the transmitter. Insert the threaded portion of the adjustable fitting into the customer supplied flange and tighten (apply pipe thread sealant if required). Be careful not to drop the flange as it can damage the transmitter.
2. Slide the product float onto the rigid pipe. Slide the interface float (optional) onto the rigid pipe. Install stop collar 2 inches from the bottom (see '**Note**' below). Do not drop the float(s) or allow them to free fall along the rigid pipe as damage may result. Install E-ring.

##### Note:

The stop collar can be removed or adjusted based on the float selected for the application. Please consult the factory for more information.

3. Slide float(s) back down to the stop collar to prevent them from free falling during installation into the tank. Insert the rigid pipe (with floats) through the tank opening and lower the transmitter/float assembly into the tank until it rests on the bottom. **DO NOT DROP OR DAMAGE THE PIPE.**
4. Secure the flange onto the tank mount.
5. Pull the transmitter upward so the end plug is just resting on the floor of the tank. Tighten the adjustable fitting to hold the transmitter in place.
6. Terminate the field wire cables noting proper wire orientation.

## FLEXIBLE PROBE

### Caution:

When assembling and installing the Model MG transmitter, be careful not to allow the flexible hose to kink or be coiled in less than 16 in. (406.5 mm) diameter. It is recommended that assembly and mounting of this transmitter should not be done alone. To ensure proper and safe assembly of the Model MG transmitter, a minimum of two (2) individuals are recommended. Gloves are also recommended. PPE is required for work areas such as safety shoes, safety glasses, hard hat, and fire resistant clothing.

### Tools Required:

- 9/16 in. Socket and ratchet
  - Channel lock pliers
  - 3/16 in. Hex key (allen wrench)
1. Remove the stop collar. With assistance, feed the flexible hose through the hole of the removed tank flange until the flange is positioned at the rigid section of pipe near the top of the transmitter. Insert the threaded portion of the adjustable fitting into the customer supplied flange and tighten (apply pipe thread sealant if required). Be careful not to drop flange on the flexible hose as damage may result.
  2. Slide the product float onto the flexible pipe. Slide the interface float (optional) onto the flexible pipe. Install stop collar 3 inches from the bottom of rigid section (see '**Note**' below). Do not drop float(s) or allow them to free fall along the flexible pipe as damage may result.

### Note:

The stop collar can be removed or adjusted based on the float selected for the application. Please consult the factory for more information.

3. Mount the hook, weight, or the magnet to the welded end-plug section of the pipe (this is the bottom rigid section of the pipe) using the supplied nut, spacer and washer, tighten securely as shown in *Figure 5*. **For the magnet, remove washer before installing in tank.**

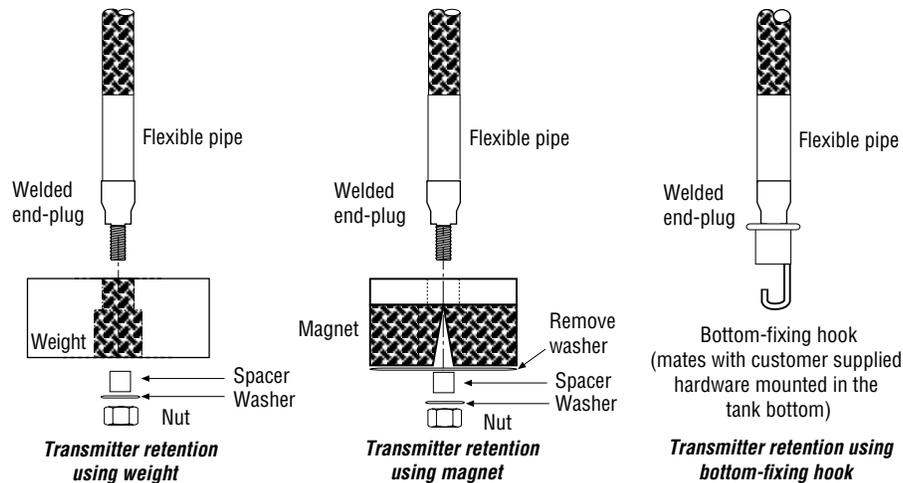

Figure 5. Bottom fixing hardware

### DO NOT DROP OR DAMAGE THE PIPE

**Important:** Avoid kinking or bending the flexible pipe in less than 16 inch (406 mm) diameter or damage may result.

4. Slide float(s) back down to the stop collar to prevent them from free falling during installation into the tank. Insert the flex pipe and floats through the tank riser pipe and lower the transmitter/float assembly into the tank until it rests on the bottom. If you are using a bottom-fixing hook, fasten the hook to the appropriate customer-supplied mating hardware at the tank bottom.
5. Secure the flange onto the tank riser pipe.
6. Pull the transmitter upward to straighten the flexible pipe until the resistance of the weight, magnet, or hook is felt without raising the weight or magnet off the floor of the tank. Tighten the adjustable fitting to hold the transmitter in place.
7. Terminate the field wire cables noting proper wire orientation.

**Mounting**

The method of mounting the Level Plus M-Series transmitter is dependent on the vessel or tank in which it is being used, and what type of transmitter is being mounted. There are three typical methods for mounting; threaded flange mounting, welded flange mounting, and sanitary tri-clamp mounting.

**THREADED FLANGE MOUNTING**

In most applications, the Model MG transmitter can be mounted directly to the tank or flange via a NPT threaded fitting, assuming there is a proper threaded connection available. If the float will not fit through the flange opening when the flange is removed, there must be some alternative means to mount the float on the transmitter from inside the vessel; this may require an access port nearby the entry point of the transmitter as shown in *Figure 6*.

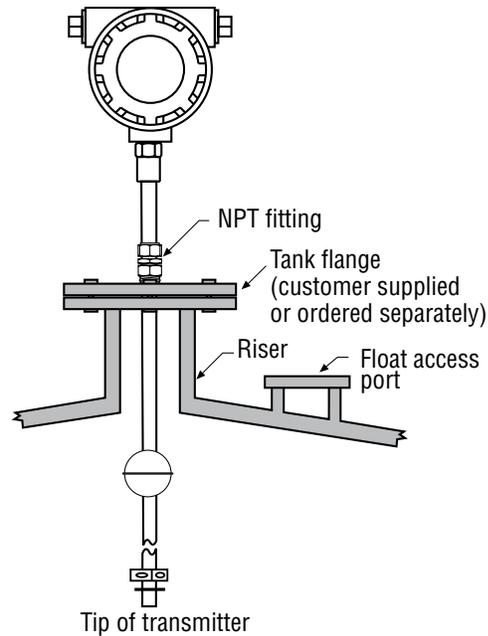

**Figure 6.** Threaded flange mounting for rigid (shown) and flexible pipe

**WELDED FLANGE MOUNTING**

The Model MG transmitter can also be mounted to a tank flange as shown in *Figure 7*. First, install float(s) onto the transmitter. Second, install the float retaining hardware on the tip of the transmitter. To complete the installation, mount the transmitter, flange and float(s) as a unit in to the tank.

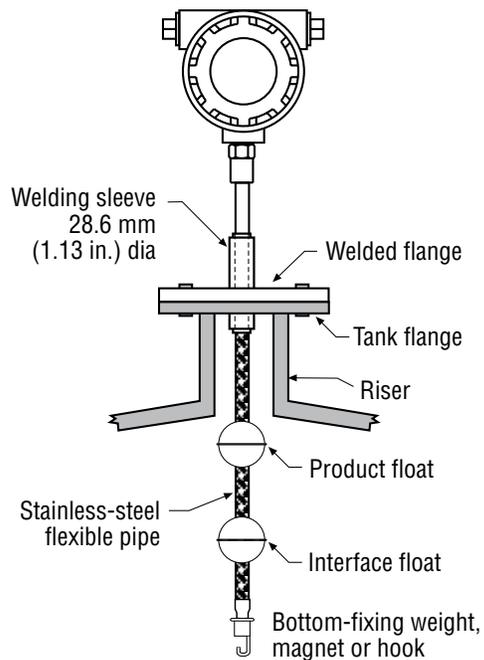

**Figure 7.** Welded flange mounting for rigid and flexible (shown) pipe

### SANITARY TRI-CLAMP MOUNTING

In sanitary applications, the M-Series transmitter is mounted to the tank using a standard sanitary connection and clamp as shown in *Figure 8*. In most cases it is not necessary to remove the float as the sanitary end-plug fitting is sized to allow installation with the float in place. Please note that some sanitary end-plug styles have float(s) permanently mounted as shown in *Figure 8*. To install the clamp, the transmitter and float(s) into the mating process connection and attach the sanitary tri-clamp.

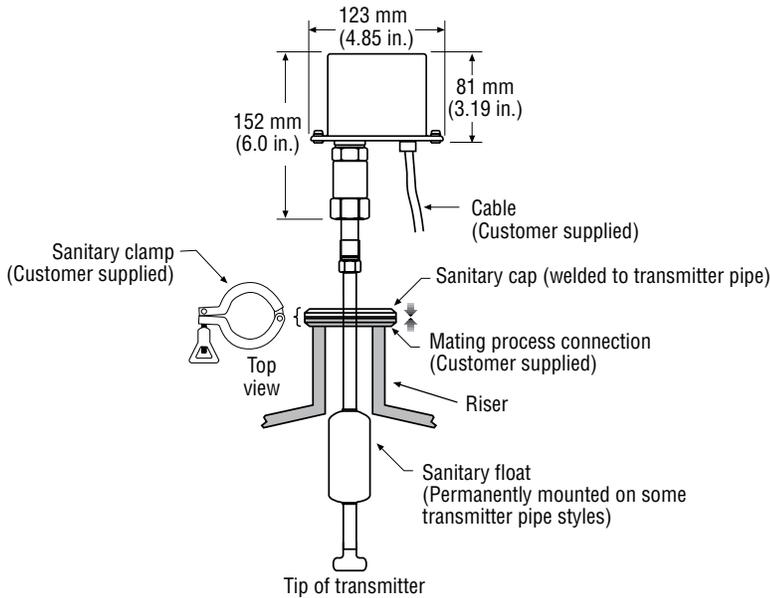

**Figure 8.** M-Series Model MG transmitter. Tank mounted with sanitary connection

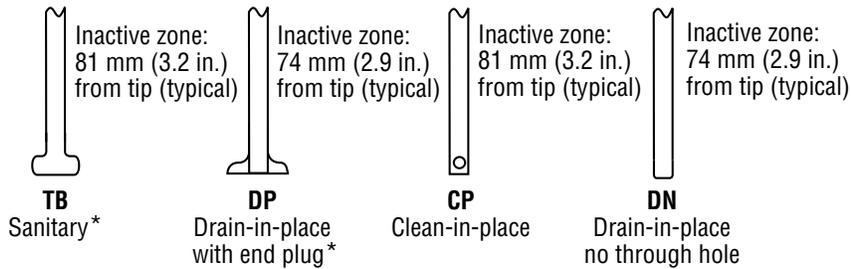

\* This end plug style has permanently mounted floats. Floats cannot be removed from pipe.

**Figure 9.** End-plug options for transmitters in a sanitary pipe application

## Electrical connections and wiring procedures

A typical intrinsically safe connection for the Level Plus M-Series transmitter includes protective safety barriers, a power supply and a reading or monitoring device. Refer to *Agency information* and *Brief Operation Manual for Safe Use* for detailed information.

A typical explosion proof connection for the M-Series transmitter includes a power supply and a reading or monitoring device connected using explosion proof conduit. Refer to *Agency information* and *Brief Operation Manual for Safe Use* for detailed information.

### Notes:

For explosion proof installation, safety barriers are not required and wiring shall be installed in accordance with the National Electric Code ANSI/NFPA 70, Article 501-30 or the regional equivalent.

## Safety recommendations for installation

Always follow applicable local and national electrical codes and observe polarity when making electrical connections. Never make electrical connections to the M-Series transmitter with power turned on. Make sure that no wire strands are loose or sticking out of the terminal block connection which could short and cause a problem. Make sure that no wire strands, including shield, are in contact with the electronic module enclosure. The electronics module enclosure is grounded through internal circuitry and electrically isolated from the explosion-proof enclosure.

## Industrial topologies

There are four topologies described and illustrated below. However, the daisy chain topology is not recommended by MTS.

### POINT-TO-POINT

The point-to-point topology consists of having only one device on the loop as shown in *Figure 10*. This topology is not usually used with a bus network since it does not take advantage of placing multiple devices on a loop.

### BUS WITH SPURS

The bus with spurs topology has a main trunk cable that has each device connected via its own spur at a junction box as shown in *Figure 11*. The bus with spurs and tree topologies can also be used together to form a hybrid topology.

### TREE ALIGNMENT

The tree topology is very similar to the bus with spurs topology with the main difference of having a common junction box for all of the transmitters as shown in *Figure 12*. Bus with spurs and tree topologies can also be used together to form a hybrid topology.

### DAISY CHAIN

The daisy-chain topology utilizes a single cable that is connected to all of the transmitters with the cable being interconnected at each field device. When using this topology make sure that the wiring practice allows for one transmitter to be disconnected without disconnecting the entire loop as shown in *Figure 13*. MTS does not suggest using the daisy-chain topology.

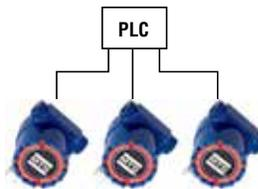

Figure 10. Point-to-point topology

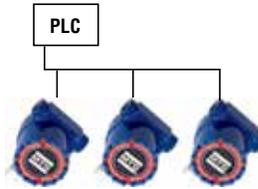

Figure 11. Bus with spurs topology

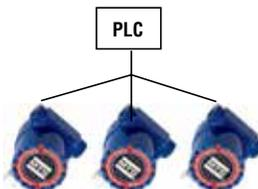

Figure 12. Tree topology

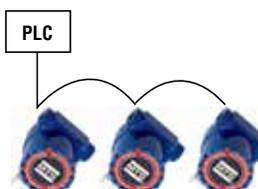

Figure 13. Daisy-chain topology

## Recommended cable types

Listed below are general requirements of cable types for the Level Plus Model MG digital transmitter.

### CABLE RECOMMENDATION FOR MODBUS AND DDA

#### Cable recommendation:

- Shielded, twisted pair, 24 AWG or heavier
- Minimum 85 °C temperature rating.
- Minimum 0.010 in. (0.25 mm) insulation thickness
- 30 picofarads/foot or less. (*see Notes*).

#### Notes:

1. The return conductor for the power supply circuit is connected to the shield at the safety barrier ground terminal. When determining the capacitance of cable for the power supply circuit, use the manufacturer's capacitance specifications shown for one conductor and the other conductor connected to the shield.
2. Most cable manufacturers do not list inductance properties for cables. Where the inductance properties are unavailable, ISA RP12.6 (Installation of Intrinsically Safe Instrument Systems in Class I Hazardous Locations) recommends the use of 0.2  $\mu\text{H}$  (micro henries) per foot as a value for cable inductance.
3. Termination and biasing of RS-485 data lines are as follows:
  - **Biasing** - Each M-Series transmitter has internal high impedance biasing resistors (30K  $\Omega$ ) on both RS-485 data lines. No additional biasing resistors should be present on the connecting devices (PLC, DCS, PC, converter).
  - **Termination** - Each M-Series transmitter has an internal termination resistor (100K  $\Omega$ ) installed across the RS-485 signal lines. No additional termination resistors are necessary in the connecting devices (PLC, DCS, PC, converter).

### CABLE RECOMMENDATION FOR FOUNDATION™ FIELDBUS

General requirements of cable types for the M-Series FOUNDATION™ fieldbus transmitter:

Type A, FOUNDATION™ fieldbus cable (*see Table 1 to the right*)

#### Parameter Value

Resistance	15 $\Omega$ /km to 150 $\Omega$ /km
Inductance	0.4mH/km to 1mH/km
Capacitance	80nF/km to 200nF/km

## Electrical conduit installation

#### Important:

Seal all conduits within 18 inches.

#### Notes:

1. Use an explosion proof type conduit sealing fitting.
2. Tighten housing cover (both front and back covers if dual cavity) to full stop against the O-ring.
3. Do not over-tighten compression fittings.
4. Use side conduit entry only.
5. In high humidity areas, use a breather drain type conduit sealing fitting to minimize moisture intrusion.

Table 1. Type A cable

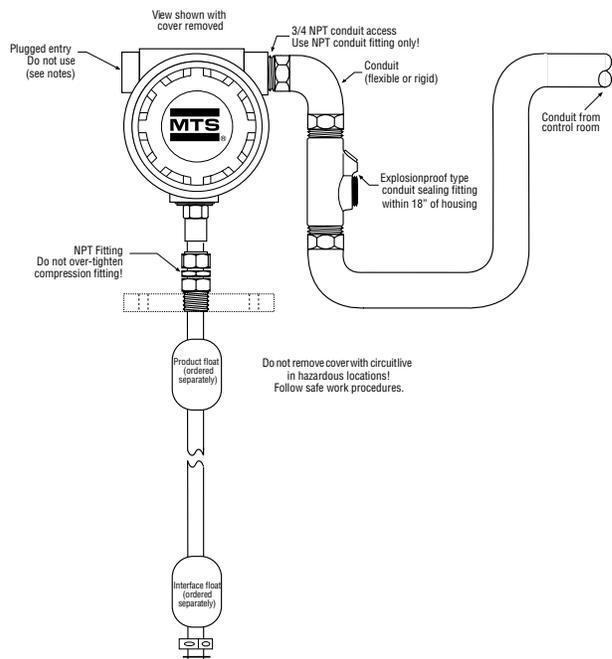

## Grounding

**Note:**

Grounding the transmitter through a threaded conduit connection does not provide sufficient ground.

There are two methods to provide an earth ground to the earth ground of the electronics.

- Run an earth ground through the conduit and connect directly to the earth ground of the electronics
- Run an earth ground directly to the ground lug on the outside of the housing and connect the ground lug inside of the housing to the earth ground of the electronics. Refer to *Table 2* and *Table 3* below for a limited listing of possible barrier selections.

## Safety barriers

**Entity Parameter**

FM	V <sub>max</sub> = 28 Vdc I <sub>max</sub> = 200 mA C <sub>i</sub> = 0µF L <sub>i</sub> = 0 mH
ATEX	U <sub>i</sub> = 28 Vdc Σ I <sub>i</sub> = 200 mA C <sub>i</sub> = Negligibly low L <sub>i</sub> = Negligibly low
CSA	V <sub>max</sub> = 30 Vdc I <sub>max</sub> = 100 mA C <sub>i</sub> = 0µF L <sub>i</sub> = 0 mH

Supplier	Type	Maximum voltage	Maximum current	Maximum power	Maximum resistance	Number of channels
STAHL	9001/01-280-165-101	28 Vdc	165 mA	1155 mW	198Ω	1
STAHL	9001/01-280-110-101	28 Vdc	110 mA	770 mW	294Ω	1
MTL	728	28 Vdc	93 mA	651 mW	300Ω	1
MTL	728+	28 Vdc	93 mA	651 mW	300Ω	1
MTL	7028+	28 Vdc	93 mA	651 mW	300Ω	1
MTL	7128+	28 Vdc	93 mA	651 mW	300Ω	1
MTL	7728+	28 Vdc	93 mA	651 mW	300Ω	1

**Table 2.** Power supply (+24 Vdc)

Supplier	Type	Maximum voltage	Maximum current (each channel)	Maximum power (each channel)	Maximum resistance (each channel)	Number of channels
STAHL	9001/01-086-010-101	8.6 Vdc	10 mA	21.5 mW	963Ω	1
STAHL	9002/11-120-024-001	12 Vdc	12 mA	70 mW	1156Ω	2
MTL	764+	12 Vdc	24 mA	72 mW	1075Ω	2

**Table 3.** Communication lines (TX/RX+ and TX/RX-)

## Maintenance and field service

This section contains information about post installation maintenance and provides an overview of MTS Sensors' repair and replacement procedures.

### General maintenance and field service requirements

#### Notes:

Please contact Technical Support or Customer Service for help when damage occurs in order to obtain a return materials authorization (RMA) number. Packages without a RMA number may be rejected. Any unit that was used in a process must be properly cleaned in accordance with OSHA standards, before it is returned to the factory. A Material Safety Data Sheet (MSDS) must accompany material that was used in any media.

#### FLOAT MAINTENANCE

Level Plus M-Series transmitters use magnetostrictive technology and only have one moving part—the float. This technology ensures no scheduled maintenance or recalibration is required. However, MTS recommends that you check the transmitter pipe annually for build up of process material. Floats should move freely along the pipe. If they do not, routine cleaning should be performed.

#### FIELD SERVICE

If damage does occur to a M-Series transmitter, the transmitter can be serviced in the field with replacement parts. All electronic parts can be changed in the field without having to open the process vessel. Please contact Technical Support and refer to the Transmitter Electronics Replacement Guide (MTS part no. 551104) for detailed steps of field replacement.

#### SERVICE / RMA POLICY

If the customer suspects their transmitter is damaged or not functioning correctly, call *MTS Technical Support* for further instruction. If it is necessary to return the transmitter to the factory, an RMA number is required and can only be issued by Technical Support. Product returns that do not include an RMA will be returned to the customer. MTS evaluates the transmitter and advises the customer whether a repair or replacement is necessary and any cost that might be incurred. If the customer declines repair/replacement or the transmitter has no fault found, the unit is sent back as is and the customer is charged with a standard evaluation fee.

If the transmitter is under warranty and a manufacturer's defect is detected, there will be no cost to the customer for repair or replacement. If the transmitter is out of warranty or if the customer has damaged the transmitter, a repair or replacement quote will be provided. In specific cases where the transmitter can not be removed and returned to the factory for evaluation, field evaluations can be performed on location by an MTS technician. If field evaluation must be performed, the customer is responsible for all expenses incurred for travel, evaluation, parts and repair time. However, if the transmitter is under warranty and the problem is due to a manufacturer's defect, there is no cost to the customer for replacement parts. To discuss all service options, contact *Technical Support*.

**Troubleshooting**

Table 4 below contains troubleshooting information for the Model MG digital transmitter.

**Troubleshooting procedures**

**Troubleshooting Procedures**

Symptom	Possible Cause	Action
<b>No communication with transmitter</b>	No power	Check voltage at transmitter
	Wiring incorrect	Reference installation drawing ( <i>see 'Electrical connections and wiring'</i> )
	Wrong address	DDA factory default is '192' Modbus factory default is '247'
	Wrong software	Confirm correct software
	Wrong protocol	Confirm software and transmitter are same protocol
<b>Missing magnet error</b>	Float not recognized	Confirm that the float is attached
	Float is in the dead zone	Raise float to see if the error stops
	Wrong number of floats selected	Confirm that the number of floats on the transmitter and the number of floats the transmitter is attempting to verify are the same.
<b>Trigger level error</b>	Gain needs to be adjusted	Consult Factory
	SE is damaged	Consult Factory
	Min. trigger level too high	Consult Factory
<b>Volume calculation error</b>	No strap table entered	Enter strap table
	Level outside range of strap table	Enter additional points in strap table
	Strap table incorrect	Check value entries
<b>VCF error</b>	No VCF table entered	Enter VCF table
	VCF table incorrect	Check VCF value entries

**Table 4.** Troubleshooting reference

## Quick start-up guide (Modbus and DDA)

### BEFORE YOU BEGIN

**Note:**

You must use a RS-485 converter with “*Send Data Control*” and the M-Series Set-up Software to ensure proper operation.

*Example:*

B & B Electronics 485BAT3 (815-433-5100 www.bb-elec.com).

### Default communication parameters

Modbus: 4800 BAUD	8, N, 1
DDA: 4800 BAUD	8, E, 1

### QUICK START-UP PROCEDURE

1. Connect +24 Vdc to terminals.
2. Connect data lines to terminals.
3. Connect the PC (or other device) to data lines.  
(If you are using a PC, use a RS-232 to RS-485 converter. See *Note* above for more information.)
4. Turn on power to the transmitter.
5. Start the M-Series Setup Software. Click the ‘**Data From Device**’ tab. Click the ‘**Device**’ pull down menu (located in the upper right corner of the window) to verify communications using factory default address ‘247’ for *Modbus* or factory default ‘192’ for *DDA*.
6. Change the address to one that is suitable for the installation network.
7. Verify proper operation of product and or interface floats and temperature.
8. Turn off power to the transmitter.
9. Remove data lines.
10. Install the transmitter into the vessel (*see Installation and mounting on page 11*).
11. Reconnect power and data lines.
12. Verify communications with the host system (*repeat step 5*).
13. Calibrate current tank level (optional). Setup is complete.

Modbus Interface

**Notes:**

Termination and biasing of RS-485 data lines are as follows:

- **Biasing**  
Each M-Series transmitter has internal high impedance biasing resistors (30K Ω) on both RS-485 data lines. No additional biasing resistors should be present on the connecting devices (PLC, DCS, PC, Converter).
- **Termination**  
Each M-Series transmitter has an internal termination resistor (100K Ω) installed across the RS-485 signal lines. No additional termination resistors are necessary in the connecting devices (PLC, DCS, PC, Converter).

**MODBUS IMPLEMENTATION**

The Modbus implementation for the M-Series digital transmitter conforms to the 'Modicon Modbus Protocol Reference Guide, PIMBUS-300 Rev. G' available from Modicon, Inc. The information provided below assumes familiarity with the Modbus protocol as outlined in this reference guide. All information provided applies to Modbus RTU protocol only.

**MODBUS FUNCTION CODES**

**Communication parameters:**

Modbus:	4800 BAUD or 9600	8, N, 1
(Reference) Monitor:	Modbus RTU Variable BAUD Rate	8, E, 1

The following Modbus function codes are supported:

- Function 03** - Read Holding Registers
- Function 04** - Read Input Registers
- Function 06** - Preset Single Register
- Function 08** - Diagnostics (Subfunction 00, Return Query Data)
- Function 08** - Diagnostics (Subfunction 01, Restart Communications Option)
- Function 08** - Diagnostics (Subfunction 04, Force Listen Only Mode)
- Function 16** - Preset Multiple Registers
- Function 17** - Report Slave ID

**Function 03 - Read Holding Registers**

The device responds to this message by returning the contents of the requested data register(s).  
(See 'Device Modbus Register Maps' on page 22).

The following implementation-specific considerations apply:

- If an unsupported or reserved register is requested, a maximum negative value (8000H or 80000000H for paired registers) is returned (See 'Device Modbus Register Maps' on page 212 for unsupported/reserved registers).
- If a register contains an device error a maximum negative value is returned.
- If a register is blank, indicating that the desired function is not

enabled (e.g., volume calculations) a value of 0000H is returned.

- Unsupported or reserved bits will always be set to 0. See 'Device Modbus Register Maps' on page 22 for alarm bit definitions.

**Function 04 - Read Input Registers**

This function is handled exactly the same as *Function 03*. (Be advised that all registers are read-only in this implementation).

**Function 06 – Preset Single Registers**

Confirmation of successful transmission is confirmed when the device responds by echoing back what was sent.

**Function 08 - Diagnostics (Subfunction 00, Return Query Data)**

The device responds to this request with the following data:

- Slave address: echoed
- Function: 08H
- Subfunction high: 00H
- Subfunction low: 00H
- Query data (16-bit): echoed
- Error check: 16-bit CRC/8-bit LRC

**Function 08 - Diagnostics (Subfunction 01, Restart Communications Option)**

**Note:**

The communications event log is not supported. The "Query data" field is irrelevant (normally, FF00H would clear the log).

If the device is in listen-only mode, the device responds to this message by switching out of listen-only mode - (resulting in no response being sent to the request).

If the device is not in listen only mode, it responds as follows:

- Slave address: echoed
- Function: 08H
- Subfunction high: 00H
- Subfunction low: 01H
- Query data (16-bit): echoed (0000H or FF00H)
- Error check: 16-bit CRC/8-bit LRC

**Function 08 - Diagnostics (Subfunction 04, Force Listen-Only Mode)**

The device responds to this request by switching to listen-only mode. Messages are still received and parsed, but no responses are transmitted. To switch out of listen-only mode, issue a '**Restart Communications Option**' request (function 08, subfunction 01) or cycle power.

**Function 16 - Preset Multiple Registers**

The device response returns the slave address, function code, starting address, and quantity of registers preset.

**MODBUS FUNCTION CODES (CONTINUED)**

**Function 17 - Report Slave ID**

The device responds to this request with the following data:

- Slave address: echoed
- Function: 11H
- Byte count: 05H
- Slave ID: FFH
- Run indicator status: FFH (ON)
- Additional data: 'DMS'
- Error check: 16-bit CRC/8-bit LRC

**Modbus Exceptions**

The following standard Modbus exceptions are implemented:

**Error code 01 (Illegal Function)**

*Reported when:*

- A function other than 03, 04, 06, 08, 16 or 17 is requested
- Function 08 is requested, and a subfunction other than 00, 01, or 04 is requested

**Error code 02 (Illegal Data Address)**

*Reported when:*

- Function 03 or 04 is requested and the starting register number is greater than 5198 (register greater than 35198 or 45198)

**Error code 03 (Illegal Data Value)**

*Reported when:*

- Function 03 or 04 is requested and the number of data points is greater than 800.

**DEVICE MODBUS REGISTER MAPS**

Modbus Register	Data Address	Data Description ‡ denotes duplicate register	Note Reference
30001	0000	Product Level High Word (x 1000)	2, Page 26 3, Page 27
30002	0001	Product Level Low Word (x 1000)	
30003	0002	Interface Level High Word (x 1000)	
30004	0003	Interface Level Low Word (x 1000)	
30005	0004	Roof Level High Word (x 1000)	Inactive
30006	0005	Roof Level Low Word (x 1000)	Inactive
30007	0006	Temperature 1 High Word (x 10000)	4, Page 27
30008	0007	Temperature 1 Low Word (x 10000)	
30009	0008	Temperature 2 High Word (x 10000)	
30010	0009	Temperature 2 Low Word (x 10000)	
30011	0010	Temperature 3 High Word (x 10000)	
30012	0011	Temperature 3 Low Word (x 10000)	
30013	0012	Temperature 4 High Word (x 10000)	
30014	0013	Temperature 4 Low Word (x 10000)	
30015	0014	Temperature 5 High Word (x 10000)	
30016	0015	Temperature 5 Low Word (x 10000)	
30017	0016	Temperature Average High Word (x 10000)	5, Page 27

Modbus Register	Data Address	Data Description ‡ denotes duplicate register	Note Reference
30018	0017	Temperature Average Low Word (x 10000)	
30019	0018	GOVP High Word	6, Page 27
30020	0019	GOVP Low Word	
30021	0020	GOVI High Word	7, Page 27
30022	0021	GOVI Low Word	
30023	0022	GOVT High Word	8, Page 27
30024	0023	GOVT Low Word	
30025	0024	GOVU High Word	9, Page 27
30026	0025	GOVU Low Word	
30027	0026	NSVP High Word	10, Page 27
30028	0027	NSVP Low Word	
30029	0028	MASS High Word	
30030	0029	MASS Low Word	
30031	0030	Temperature Correction Method High Word	11, Page 27
30032	0031	Temperature Correction Method Low Word	
30033	0032	API Gravity High Word (x 100)	
30034	0033	API Gravity Low Word (x 100)	
30035	0034	Working Capacity High Word (x 10)	
30036	0035	Working Capacity Low Word (x 10)	
30037	0036	TEC High Word (x 10000000)	12, Page 27
30038	0037	TEC Low Word (x 10000000)	

## Model MG Operation and Installation Manual

### Modbus User Interface

#### DEVICE MODBUS REGISTER MAPS (CONTINUED)

Modbus Register	Data Address	Data Description ‡ denotes duplicate register	Note Reference
30039	0038	Density High Word (x 100)	13, Page 27
30040	0039	Density Low Word (x 100)	
30041	0040	Reference Temperature High Word (x 10)	14, Page 27
30042	0041	Reference Temperature Low Word (x 10)	
30043	0042	Volume Calculation Mode High Word	15, Page 27
30044	0043	Volume Calculation Mode Low Word	
30045	0044	Sphere Radius High Word (x 10)	16, Page 27
30046	0045	Sphere Radius Low Word (x 10)	
30047	0046	Sphere Offset High Word (x 10)	17, Page 27
30048	0047	Sphere Offset Low Word (x 10)	
30049	0048	Average Interval High Word	18, Page 27
30050	0049	Average Interval Low Word	
30051	0050	Alarm/Status High Word	19, Page 27
30052	0051	Alarm/Status Low Word	
30053	0052	VCF Calculation Error Status	20, page 29
30054	0053	Volume Calculation Error Status	21, page 29
30055 - 30099	0054 - 0098	Reserved	22, page 29
30100	0099	Temperature Units High	23, page 29
30101	0100	Temperature Units Low	
30102	0101	Density Units High	24, page 29
30103	0102	Density Units Low	
30104	0103	Volume Units High	25, page 29
30105	0104	Volume Units Low	
30106	0105	Length Units High	26, page 29
30107	0106	Length Units Low	
30108	0107	Mass Units High	27, page 29
30109	0108	Mass Units Low	
30110	0109	Set New Device Address	28, page 29
30200	199	Product Level High Word (x1000) ‡	2, Page 26 3, Page 27
30201	200	Product Level Low Word (x1000) ‡	

Modbus Register	Data Address	Data Description ‡ denotes duplicate register	Note Reference
30202	201	Interface Level High Word (x1000) ‡	
30203	202	Interface Level Low Word (x1000) ‡	
30204	203	Roof Level High Word (x1000) ‡	Inactive
30205	204	Roof Level Low Word (x1000) ‡	Inactive
30206	205	Temperature 1 High Word (x10000)	4, Page 27
30207	206	Temperature 1 Low Word (x10000)	
30208	207	Temperature 2 High Word (x10000)	
30209	208	Temperature 2 Low Word (x10000)	
30210	209	Temperature 3 High Word (x10000)	
30211	210	Temperature 3 Low Word (x10000)	
30212	211	Temperature 4 High Word (x10000)	
30213	212	Temperature 4 Low Word (x10000)	
30214	213	Temperature 5 High Word (x10000)	
30215	214	Temperature 5 Low Word (x10000)	
30216	215	Temperature 6 High Word (x10000)	
30217	216	Temperature 6 Low Word (x10000)	
30218	217	Temperature 7 High Word (x10000)	
30219	218	Temperature 7 Low Word (x10000)	
30220	219	Temperature 8 High Word (x10000)	
30221	220	Temperature 8 Low Word (x10000)	
30222	221	Temperature 9 High Word (x10000)	
30223	222	Temperature 9 Low Word (x10000)	
30224	223	Temperature 10 High Word (x10000)	
30225	224	Temperature 10 Low Word (x10000)	
30226	225	Temperature 11 High Word (x10000)	
30227	226	Temperature 11 Low Word (x10000)	
30228	227	Temperature 12 High Word (x10000)	
30229	228	Temperature 12 Low Word (x10000)	

DEVICE MODBUS REGISTER MAPS (CONTINUED)

Modbus Register	Data Address	Data Description ‡ denotes duplicate register	Note Reference
30230	229	Temperature Average High Word (x10000)	5, Page 27
30231	230	Temperature Average Low Word (x10000)	
30232	231	GOVP High Word ‡	6, Page 27
30233	232	GOVP Low Word ‡	
30234	233	GOVI High Word ‡	7, Page 27
30235	234	GOVI Low Word ‡	
30236	235	GOVT High Word ‡	8, Page 27
30237	236	GOVT Low Word ‡	
30238	237	GOVU High Word ‡	9, Page 27
30239	238	GOVU Low Word ‡	
30240	239	NSVP High Word ‡	10, Page 27
30241	240	NSVP Low Word ‡	
30242	241	MASS High Word ‡	
30243	242	MASS Low Word ‡	
30244	243	Temperature Correction Method High Word ‡	11, Page 27
30245	244	Temperature Correction Method Low Word ‡	
30246	245	API Gravity High Word (x100) ‡	
30247	246	API Gravity Low Word (x100) ‡	
30248	247	Working Capacity High Word (x10) ‡	
30249	248	Working Capacity Low Word (x10) ‡	
30250	249	TEC High Word (x10000000) ‡	12, Page 27
30251	250	TEC Low Word (x10000000) ‡	
30252	251	Density High Word (x100) ‡	13, Page 27
30253	252	Density Low Word (x100) ‡	
30254	253	Reference Temperature High Word (x10) ‡	14, Page 27
30255	254	Reference Temperature Low Word (x10) ‡	
30256	255	Volume Calculation Mode High Word ‡	15, Page 27
30257	256	Volume Calculation Mode Low Word ‡	
30258	257	Sphere Radius High Word (x10) ‡	16, Page 27

Modbus Register	Data Address	Data Description ‡ denotes duplicate register	Note Reference
30259	258	Sphere Radius Low Word (x10) ‡	
30260	259	Sphere Offset High Word (x10) ‡	17, Page 27
30261	260	Sphere Offset Low Word (x10) ‡	
30262	261	Average Interval High Word ‡	18, Page 27
30263	262	Average Interval Low Word ‡	
30264	263	Alarm/Status High Word ‡	19, Page 27
30265	264	Alarm/Status Low Word ‡	
30266	265	VCF Calculation Error Status ‡	20, page 28
30267	266	Volume Calculation Error Status ‡	21, page 28
30300	299	Temperature Units High ‡	23, page 28
30301	300	Temperature Units Low ‡	
30302	301	Density Units High ‡	24, page 28
30303	302	Density Units Low ‡	
30304	303	Volume Units High ‡	25, page 28
30305	304	Volume Units Low ‡	
30306	305	Length Units High ‡	26, page 28
30307	306	Length Units Low ‡	
30308	307	Mass Units High ‡	27, Page 27
30309	308	Mass Units Low ‡	
30310	309	Set New Device Address ‡	28, page 28
31101	1100	Tank offset High (x 10)	29, page 28
31102	1101	Tank Offset Low (x 10)	
31103	1102	Calibrate Using Current Product Level High (x 1000)	30, page 28
31104	1103	Calibrate Using Current Product Level Low (x 1000)	
31105	1104	Calibrate Using Current Interface Level High (x 1000)	31, page 28

DEVICE MODBUS REGISTER MAPS (CONTINUED)

Modbus Register	Data Address	Data Description ‡ denotes duplicate register	Note Reference
31106	1105	Calibrate Using Current Interface Level Low (x 1000)	
31107	1106	Calibrate Using Current Roof Level High (x 1000)	32, Page 29
31108	1107	Calibrate Using Current Roof Level Low (x 1000)	
31109	1108	Alarm Units High	33, Page 29
31110	1109	Alarm Units Low	
31111	1110	Interface High Alarm High (x 100)	34, Page 29
31112	1111	Interface High Alarm Low (x 100)	
31113	1112	Interface Low Alarm High (x 100)	35, Page 29
31114	1113	Interface Low Alarm Low (x 100)	
31115	1114	Product High Alarm High (x 100)	36, Page 29
31116	1115	Product High Alarm Low (x 100)	
31117	1116	Product Low Alarm High (x 100)	37, Page 29
31118	1117	Product Low Alarm Low (x 100)	
31119	1118	Roof High Alarm High (x 100)	38, Page 29
31120	1119	Roof High Alarm Low (x 100)	
31121	1120	Roof Low Alarm High (x 100)	39, Page 29
31122	1121	Roof Low Alarm Low (x 100)	
31123	1122	Temperature Average High Alarm High (x 100)	40, Page 29
31124	1123	Temperature Average High Alarm Low (x 100)	
31125	1124	Temperature Average Low Alarm High (x 100)	41, Page 29
31126	1125	Temperature Average Low Alarm Low (x 100)	
31127–31998	1126 – 1997	Reserved	22, page 28
31999	1998	Number Of Strap Table Entries High	42, Page 29
32000	1999	Number Of Strap Table Entries Low	
32001	2000	Strap Table Level 1 High (x 10000)	43, Page 29

Modbus Register	Data Address	Data Description ‡ denotes duplicate register	Note Reference
32002	2001	Strap Table Level 1 Low (x 10000)	
32003	2002	Strap Table Level 2 High (x 10000)	
32004	2003	Strap Table Level 2 Low (x 10000)	
32005	2004	Strap Table Level 3 High (x 10000)	
32006	2005	Strap Table Level 3 Low (x 10000)	
↓	↓		
32199	2198	Strap Table Level 100 High (x 10000)	44, Page 29
32200	2199	Strap Table Level 100 Low (x 10000)	
32201	2200	Strap Table Volume 1 High	45, Page 29
32202	2201	Strap Table Volume 1 Low	
32203	2202	Strap Table Volume 2 High	
32204	2203	Strap Table Volume 2 Low	
32205	2204	Strap Table Volume 3 High	
32206	2205	Strap Table Volume 3 Low	
↓	↓		
32399	2398	Strap Table Volume 100 High (x 10000)	46, Page 29
32400	2399	Strap Table Volume 100 Low (x 10000)	
32401 – 34998	2400 – 4997	Reserved	
34999	4998	Number Of VCF Table Entries High	47, Page 29
35000	4999	Number Of VCF Table Entries Low	
35001	5000	VCF Table Temperature 1 High (x 10000)	48, Page 29
35002	5001	VCF Table Temperature 1 Low (x 10000)	
35003	5002	VCF Table Temperature 2 High (x 10000)	

DEVICE MODBUS REGISTER MAPS (CONTINUED)

Modbus Register	Data Address	Data Description ‡ denotes duplicate register	Note Reference
35004	5003	VCF Table Temperature 2 Low (x 10000)	
35005	5004	VCF Table Temperature 3 High (x 10000)	
35006	5005	VCF Table Temperature 3 Low (x 10000)	
↓	↓		
35099	5098	VCF Table Temperature 50 High (x 10000)	49, page 30
35100	5099	VCF Table Temperature 50 Low (x 10000)	
35101	5100	VCF Table Correction 1 High (x 10000)	50, page 30

Modbus Register	Data Address	Data Description ‡ denotes duplicate register	Note Reference
35102	5101	VCF Table Correction 1 Low (x 10000)	
35103	5102	VCF Table Correction 2 High (x 10000)	
35104	5103	VCF Table Correction 2 Low (x 10000)	
35105	5104	VCF Table Correction 3 High (x 10000)	
35106	5105	VCF Table Correction 3 Low (x 10000)	
↓	↓		
35199	5198	VCF Table Correction 50 High (x 10000)	51, page 30
35200	5199	VCF Table Correction 50 Low (x 10000)	

SPECIAL/ADVANCED DIAGNOSTIC REGISTER MAPS

Modbus Register	Data Address	Data Description	Note Reference
35201	5200	Num_Lineariztion_Entries_Hi Num_Lineariztion_Entries_Lo	
35203	5202 - 5999	Lintable_Level1_Hi Lintable_Level1_Lo	
35601	5600	Lintable_Level200_Hi Lintable_Level200_Lo	
35603	5602 - 5999	Lintable_Error1_Hi Lintable_Error1_Lo	

Modbus Register	Data Address	Data Description	Note Reference
36001	6000	Lintable_Error200_Hi Lintable_Error200_Lo	
36003	6002 - 6399	Lintable_Slope1_Hi Lintable_Slope1_Lo	
36401	6400	Lintable_Slope200_Hi Lintable_Slope200_Lo	

HOW UNITS ARE USED

Registers that are read or preset are done so using the current unit type's programmed unit.

For example:

If the current unit type is 'Length' and you currently have selected 'Feet' as your unit, then the value returned will be in that unit. Make sure the value programmed is also done so using that unit.

MODBUS REGISTER MAP NOTE REFERENCES

1. All registers can be accessed using either *Modbus Function 03* (Read Holding Registers) or *Modbus Function 04* (Read Input Registers). However, all registers are read-only in this implementation.

For example:

Registers 30001 and 30002 (using Function 03) can also be read as registers 40001 and 40002 (using Function 04).

2. Pairs of registers identified as 'High Word' and 'Low Word' must be read together reading the 'High Word' first. Both values need to be concatenated by the master to form a 32-bit unsigned 'long word' quantity.

For example:

Register 30001 (16-bit high word) = 0002H (Must be read first) Register 30002 (16-bit low word) = 3F8CH

Long word (32-bit) = 00023F8CH (decimal 147340)

Or:

Register 30001 (high word) = 2

Register 30002 (low word) = 16268

Multiply register 30001 x 65536 : 2 x 65536 = 131072

Add result to register 30002 : 131072 + 16268 = 147340

DEVICE MODBUS REGISTER MAPS (CONTINUED)

- 3. All registers identified as '(x 10)', '(x 100)', '(x 10000)', '(x 100000000)' or '(x 1000)' have been scaled (multiplied) by a factor of 10, 100, 1000, 10000 or 100000000 before transmission to preserve the fractional portion of the data value. The master must divide these values by the scale factor as necessary.

For example:

Register 30001 (16-bit high word) = 0002H  
Long word (32-bit) = 00023F8CH (decimal 147340)  
Divide by 1000, actual value = 147.340

- 4. **Individual digital temperature**
- 5. **Average submerged temperature**
- 6. **GOVP** = Gross Observed Volume Product
- 7. **GOVI** = Gross Observed Volume Interface
- 8. **GOVT** = Gross Observed Volume Total
- 9. **GOVU** = Gross Observed Volume Ullage
- 10. **NSVP** = Net Standard Volume of Product

11. **Temperature Correction Method**

There are five methods to choose from:

- 1 = (6A) Heavy Oils
- 2 = (6B) Light Oils
- 3 = (6C) Chemicals
- 4 = Chemicals with wider coefficients than 6C and a movable reference temperature (6C Mod).
- 5 = Custom Table.

12. **Thermal Expansion Coefficient (TEC)**

Temperature correction method '6C' uses the thermal expansion coefficient of the product being measured to determine the volume correction factor. Allowable values are 270.0 to 930.0. TEC Units are in 10E-6/Deg F.

13. **Density**

Temperature correction method '6C' and 'Custom Table' requires you to enter the density (at the given reference temperature) of the product being measured for the net mass calculation.

14. **Reference Temperature**

This is the desired base temperature for the VCF calculation when Temperature Correction Method '6C Mod' is used.

15. **Volume Calculation Mode**

This is the mode you wish the volume calculations to be performed by:

- 1 = Use Strap Table
- 0 = Use Sphere Calculation

16. **Sphere Radius**

The radius of the sphere when volume calculations are performed (using the sphere calculation mode).

17. **Sphere Offset**

The offset of the sphere when volume calculations are performed (using the sphere calculation mode).

18. **Average Interval**

All level, temperature and volume calculation can be averaged using timed method. Allowable values are as follows:

- 0 = 1 second (default)
- 5 = 5 seconds
- 10 = 10 seconds
- 15 = 15 seconds
- 20 = 20 seconds
- 25 = 25 seconds
- 30 = 30 seconds
- 35 = 35 seconds
- 40 = 40 seconds
- 45 = 45 seconds
- 50 = 50 seconds
- 55 = 55 seconds
- 60 = 60 seconds

19. **Alarm/Status bit definitions:**

- D1 Interface Alarm High
- D2 Interface Alarm Low
- D3 Product Alarm High
- D4 Product Alarm Low
- D5 Roof Alarm High
- D6 Roof Alarm Low
- D7 Average Temperature Alarm High
- D8 Average Temperature Alarm Low
- D9 Magnet Is Missing
- D10 Digital Temperature 0 Error
- D11 Digital Temperature 1 Error
- D12 Digital Temperature 2 Error
- D13 Digital Temperature 3 Error
- D14 Digital Temperature 4 Error
- D15 Digital Temperature Average Error
- D16 – D32 Reserved

For each corresponding alarm bit:

- 0 = ALARM OFF
- 1 = ALARM ON
- Reserved bits will always be set to 0 (OFF).

## DEVICE MODBUS REGISTER MAPS (CONTINUED)

### 20. Volume Correction Factor Calculation Error Status.

This value can only be read. If there is no error performing the volume correction factor then the value is zero otherwise, the value is a non-zero code and one of the following:

- 1 = Invalid API value or invalid temperature input value for 6A or 6B VCF calculation.
- 2 = Invalid API value or invalid temperature input range for 6A VCF calculation.
- 3 = Invalid API value or invalid temperature input range for 6B VCF calculation.
- 4 = Invalid API value or invalid temperature input value for 6C VCF calculation.
- 5 = Invalid API value or invalid temperature range for 6C VCF calculation.
- 6 = Invalid API value or invalid temperature range for 6C Wide VCF calculation.
- 7 = Invalid delta temperature for 6C VCF calculation.
- 8 = Interpolation error, temperature value not found in the table.
- 9 = Invalid or No VCF method selected.

### 21. Volume Calculation Error Status

This value can only be read. If there is no error performing the volume calculations then the value is zero otherwise the value is a non-zero code and one of the following:

- 1 = Negative table entries are not allowed.
- 2 = Interpolation error, level value not found in the table.
- 3 = Sphere Calculation error, level exceeds sphere radius x 2.
- 4 = Calculated a negative volume value.

22. **Undefined or reserved registers within the register map** will return a maximum negative value (*8000H*, or *80000000H* for register pairs). Attempting to read registers outside the register map (*35198 or higher*) will cause a Modbus Exception Error Code 02 (*Illegal Data Value*) to be returned.

### 23. Temperature Units

The value for temperature units can be one of the following codes:

- 0 = Celsius
- 1 = Fahrenheit

### 24. Density Units High

The value for density units can be one of the following codes:

- 0 = Grams/Milliliters
- 1 = Grams/Liter
- 2 = Kilograms/Cubic Meters
- 3 = Kilograms/Liter
- 4 = Pounds/Cubic Inch
- 5 = Pounds/Cubic Foot
- 6 = Pounds/Gallon
- 7 = Tonnes/Cubic Meter
- 8 = Tons/Cubic Yard

### 25. Volume Units

The value for volume units can be one of the following codes:

- 0 = Liters
- 1 = Cubic Millimeters
- 2 = Cubic Meters
- 3 = Cubic Inches
- 4 = Cubic Feet
- 5 = Gallons
- 6 = Barrels

### 26. Length Units

The value for length units can be one of the following codes:

- 0 = Millimeters
- 1 = Centimeters
- 2 = Meters
- 3 = Kilometers
- 4 = Inches
- 5 = Feet
- 6 = Yards

### 27. Mass Units

The value for mass units can be one of the following codes:

- 0 = Kilograms
- 1 = Grams
- 2 = Ounces
- 3 = Pounds
- 4 = Tons
- 5 = Tonnes

### 28. Set New Device Address

This register will program the new device address. Valid values for *Modbus* are between: 1 – 247.

### 29. Tank Offset

This is the value that will be added or subtracted from the level measurements.

This allows the tank level reading to be calibrated to the users hand gauged tank reading (or other reference guide).

(See notes 30, 31 and 32) for more information.

### 30. Calibrate Using Current Product Level

This is used to calibrate the level measurements. This allows the user to enter the hand gauged tank reading (or other level reference guide) of the Product and the device will calculate the necessary calibration offset.

The calculated value will then be stored as the 'Tank Offset'. (See note 29)

### 31. Calibrate Using Current Interface Level

This is used to calibrate the level measurements. This allows the user to enter the hand gauged tank reading (or other level reference guide) of the Interface and the device will calculate the necessary calibration offset.

The calculated value will then be stored as the 'Tank Offset'. (See note 29)

DEVICE MODBUS REGISTER MAPS (CONTINUED)

32. Calibrate Using Current Roof Level

This is used to calibrate the level measurements. This allows the user to enter the hand gauged tank reading (or other level reference guide) of the Roof and the device will calculate the necessary calibration offset.

The calculated value will then be stored as the 'Tank Offset'.  
(See note 29)

33. Alarm Units

This register programs the unit type for which you can configure alarms. Product and Interface can be 'Volume or 'Length' unit type, however Roof can only be 'Length' unit type.

Valid Values are as follows:

- 2 = Volume Units Type.
- 3 = Length Units Type.

34. Interface High Alarm

The value for which the Interface cannot be >=. Make sure the value is programmed in the current Alarm Units type.  
(See Note 33)

35. Interface Low Alarm

The value for which the Interface cannot be <=. Make sure the value is programmed in the current Alarm Units type. (See Note 33)

36. Product High Alarm

The value for which the Product cannot be >=. Make sure the value is programmed in the current Alarm Units type. (See Note 33)

37. Product Low Alarm

The value for which the Product cannot be <=. Make sure the value is programmed in the current Alarm Units type. (See Note 33)

38. Roof High Alarm

The value for which the Roof cannot be >=. This value can only be in unit type of Length. (See Note 33)

39. Roof Low Alarm

The value for which the Roof cannot be <=. This value can only be in unit type of Length. (See Note 33)

40. Temperature Average High Alarm

The value for which the Average Temperature cannot be >=.

41. Temperature Average Low Alarm

The value for which the Average Temperature cannot be <=.

42. Number Of Strap Table Entries

This value specifies the number of strap table entries to be used in the tank-strapping table.  
Table sizes can range from 2 to 100 entries.

43. Strap Table Level 1

This is the register for the first strap table level value entry. Each register can be accessed individually (but programmed in pairs) using the following formula:

$$\text{Strap Table Level 1 High} + ((\text{Desired Entry \#}) * 2) - 2.$$

For example,

if you wanted to program the 50th table entry:  
 $32000 + ((50 * 2) - 2) = 32098.$

You can program the entire table by setting the strap table Level 1 High register (32000) as your first register and a length of 100 using Modbus Function 16. You could also use Modbus Function 6 to program a single register pair.

44. Strap Table Level 100

This is the register for the last strap table Level value entry.  
(See note 43) for details.

45. Strap Table Volume 1

This is the register for the first strap table volume value entry. Each register can be accessed individually (but programmed in pairs) using the following formula:

$$\text{Strap Table Volume 1 High} + ((\text{Desired Entry \#}) * 2) - 2$$

For example,

If you wanted to program the 50th table entry:  
 $32200 + ((50 * 2) - 2) = 32298.$

You can program the entire table by providing the strap Table Volume 1 High register (32000) as your first register and a length of 100 using Modbus Function 16. You could also use Modbus Function 6 to program a single register pair.

46. Strap Table Volume 100

This is the register for the last strap table Volume value entry.  
(See note 45) for details.

47. Number of VCF Table Entries

This value specifies the number of VCF table entries to be used in the volume correction factor table.  
Table sizes can range from 2 to 50 entries.

48. VCF Table Temperature 1

This is the register for the first VCF table Temperature value entry.

Each register can be accessed individually (but programmed in pairs) using the following formula:

$$\text{VCF table Temperature 1 High} + ((\text{Desired Entry \#}) * 2) - 2.$$

For example,

if you wanted to program the 25th table entry:  
 $35000 + ((25 * 2) - 2) = 35048.$

You can program the entire table by providing the VCF table

Temperature 1 High register (35000) as your first register and a length of 50 using Modbus Function 16. You could also use Modbus Function 6 to program a single register pair.

**49. VCF Table Temperature 50**

This is the register for the last VCF table Temperature value entry. (See note 48) for more information.

**50. VCF Table Correction 1**

This is the register for the first VCF table Correction value entry. Each register can be accessed individually (but programmed in pairs) using the following formula:

VCF table Correction 1 High + ((Enter Entry #) \* 2) – 2.  
For example,  
if you wanted to program the 25th table entry:  
 $35100 + ((25 * 2) - 2) = 35148.$

You can program the entire table by providing the VCF table Correction 1 High register (35100) as your first register and a length of 50 using Modbus Function 16. You could also use Modbus Function 6 to program a single register pair.

**51. VCF Table Correction 50**

This is the register for the last VCF table Correction value entry. (See note 50) for more information.

**Formulas used in volume calculation**

- 1. **GOVP = GOVT - GOVI** (two float system)  
**GOVP = GOVT** (one float system)  
**GOVT = GOVP + GOVI** (two float system)  
**GOVT = GOVP** (one float system)  
**GOVU = WORKING CAPACITY - GOVT** (one or two float system)

The gross observed volume of the product (GOVP) is equal to the total volume of the tank (GOVT) minus the interface volume (GOVI). The GOVT is measured by the product float (the float closest to the flange of the transmitter) and the GOVI is measured by the interface float (the float closest to the tip of the transmitter). The level information from the transmitter is used along with the strap table to calculate the corresponding gross observed volumes.

**2. NSVP = GOVP x VCF**

The net standard volume of the product (NSVP) is equal to the gross observed volume of the product (GOVP) multiplied by the volume correction factor (VCF). The VCF is calculated from thermal expansion properties of the product (programmed by the user) and the temperature information from the gauge. (see 4. VOLUME CORRECTION FACTOR) for details.

**3. MASS = NSVP x DENSITY**

The mass of the product (MASS) is equal to the net standard volume of the product (NSVP) multiplied by the density of the product (DENSITY) programmed by the user.

**4. VOLUME CORRECTION FACTOR**

$$VCF = EXP \{- A(T) \times (t-T) \times [1 + (0.8 \times A(T) \times (t-T))]\}$$

Where:

- t = any temperature\*
- T = BASE TEMPERATURE (60 DEGREES F)
- A(T) = coefficient of thermal expansion at the base temperature T

Where:

EXP is the exponential function (e<sup>x</sup>).

The coefficient of thermal expansion at the base temperature is related to the density of the product at the base temperature T by:

$$A(T) = [K0 + K1 \times DEN(T)] / [DEN(T) \times DEN(T)]$$

Where:

- Density is defined in units of KG/M<sup>3</sup>
- K0 and K1 are constants related to each product.
- \*API 2540 states that temperature data is rounded to the nearest tenth (0.1) degree.

This section includes all the constants used by the software to calculate the volume correction factors and valid ranges for the API (density) and temperature data.

<b>Constants:</b>	K0 = 341.0957	
	K1 = 0.0	
<b>Valid temperature range</b>	<b>Valid gravity ranges (API)</b>	
0 to +300.0 °F	0 to 40.0 °API	
0 to +250.0 °F	40.1 to 50.0 °API	
0 to +200.0 °F	50.1 to 100.0 °API	

**Table 5.** 6A heavy oils

FORMULAS USED IN VOLUME CALCULATIONS (CONTINUED)

Product type	Constants	Valid gravity range (API)
Fuel oil	K0 = 103.8720 K1 = 0.2701	0.0 to 37.0 °API
Jet group	K0 = 330.3010 K1 = 0.0	37.1 to 47.9 °API
Transition group	K0 = 1489.0670 K1 = -0.0018684	48.0 to 52.0 °API
Gasoline	K0 = 192.4571 K1 = 0.2438	52.1 to 85.0 °API
Valid temperature ranges		Valid TEC ranges
0 to +300.0 °F		0 to 40.0 °API
0 to +250.0 °F		40.1 to 50.0 °API
0 to +200.0 °F		50.1 to 85.0 °API

Table 6. 6B light oils

Valid temperature range	Valid TEC ranges
0 to +300.0 °F	270.0 to 510.0 * 10E-6/ °F
0 to +250.0 °F	510.5 to 530.0 * 10E-6/ °F
0 to +200.0 °F	530.5 to 930.0 * 10E-6/ °F

\*For the transition group, A(T) = [K1 + K0 (DEN (T) x DEN (T))]  
\*\*TEC is the thermal expansion coefficient of the product being measured

Table 7. 6C chemicals

Valid temperature range	Valid TEC ranges
0 to +300.0 °F	100.0 to 999.0 * 10E-6/ °F

\*For the transition group, A(T) = [K1 + K0 (DEN (T) x DEN (T))]

Table 8. 6C MOD

**Note:**

Volumetric modes 6C MOD and CUST TAB are not intended for custody transfer applications since they do not follow API standard 2540 exactly. The software for 6C MOD incorporates a moveable temperature reference and allows for a wider range of TEC values.

Installing the M-Series Digital Setup Software

Adjustments to the calibration and set up parameters of the transmitter can be performed using the M-Series Digital Setup Software package. The software can be run from any PC using a RS-485 to RS-232 converter (See Table 9 MTS part number references). In the 'MTS Digital Gauge Configuration - Modbus -COM' window, you will see two tabs labeled 'Data From Device' (see Figure 14) on page 32 and 'Volume Calculations' (see Figure 15 on page 32). You will use these tabs to calibrate the transmitter and change setup parameters.

**Note:**

You must use a RS-485 converter with 'Send Data Control' when using the M-Series Digital Setup software to ensure proper operation.  
Example: B & B Electronics 485BAT3 (815-433-5100 www.bb-elec.com).

M-Series PC Digital Setup Software (Modbus) CD and RS-485 to RS-232 converter	M-Series PC Digital Setup Software (Modbus) CD	RS-485 to RS-232 converter
Order number: 625051	Order number: 625052	Order number: 380075

Table 9. MTS part number references

Perform the following steps to install the transmitter setup software to establish communications with the transmitter:

1. Install Setup Software from the CD that came with your transmitter or go to [www.mtssensors.com](http://www.mtssensors.com) to download the latest version.
2. Connect transmitter to the RS-485 to RS-232 converter and attach the converter to your PC. Some PC's will require an additional Serial to USB converter.
3. Open the Software program.
4. Select **COM Port**. If you do not know which COM port to select, right click **My Computer** and select **Properties -> Hardware Tab -> Device Manager -> Ports (COM & LPT)** to view the list.
5. Click the **Device:** pull-down window and select the 'transmitter address', the factory default for Modbus is **247**.

INSTALLING THE SETUP SOFTWARE (CONTINUED)

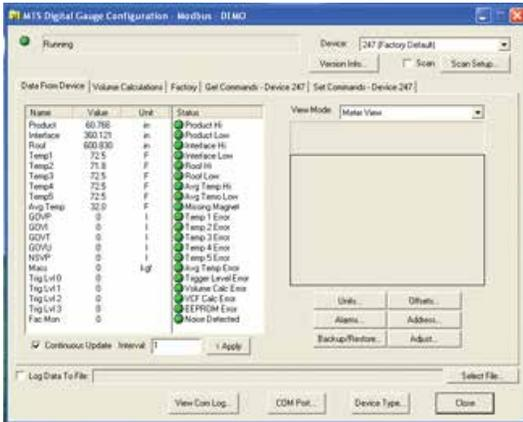

Figure 14. Data From Device tab window



Figure 15. Volume Calculations tab window

Setting up and calibrating the Model MG digital transmitter

Pages 32 to 36 contain the following software parameter information for both 'Data From Device' and 'Volume Calculations' tabs:

DATA FROM DEVICE PARAMETERS:

- Units
- Alarms
- Offset
- Address
- Backup/Restore File
- Adjust
- COM Port
- Continuous Update
- Data Logging

VOLUME CALCULATIONS PARAMETERS:

- Correction Method
- API Gravity
- Thermal Expansion Coefficient (TEC)
- Reference Temperature
- Density
- Volume Correction Factor (VCF)
- Volume Calculation Mode
- Sphere Radius
- Sphere Offset
- Working Capacity
- Average Readings
- Strap Table

DATA FROM DEVICE TAB

Units

To change Unit parameters, click the 'Units' button in the 'Data From Device' tab window. In the 'Select Units' window (See Figure 16) you can update units of measurement for length, temperature, volume, mass and density can be changed by selecting the appropriate parameter in the drop down menu, then click 'Send'. A confirmation popup window confirms the send is successful.

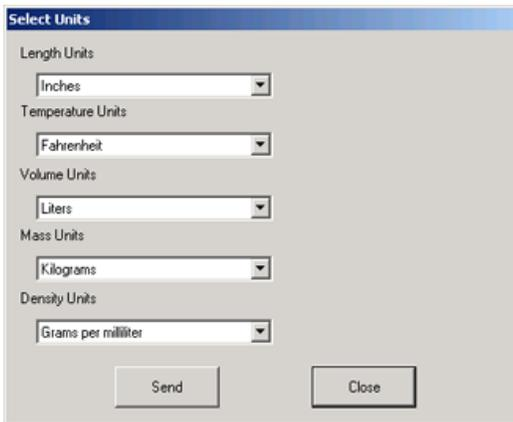

Figure 16. Select Units window

Alarms

To set the Alarms, select the 'Alarms' button in the 'Data From Device' tab window. A high and low alarm is offered for the product, interface, and average temperature and can be set to either length units or volume units from the pull down menu (See Figure 17). Each alarm needs to be checked and entered before you click the 'Send' button. A confirmation popup window confirms the send is successful.

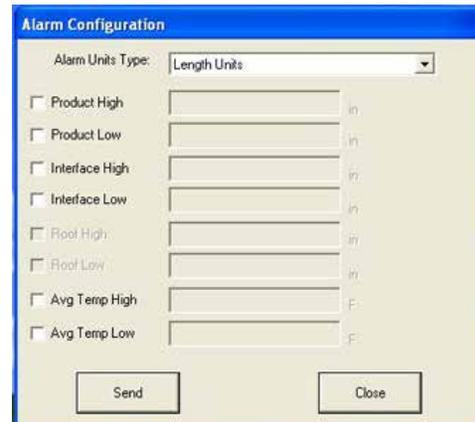

Figure 17. Alarm Configuration window

DATA FROM DEVICE TAB (CONTINUED)

Calibration

When you click the **'Offset'** button in the 'Data From Device' tab window, the *'Offsets'* window opens. There are two calibration 'Offset Methods' to choose from, **'Enter Current Tank Level'** and **'Enter Level Offset'**. Click to open the **'Offset Method:'** drop down menu and select a calibration method. Choose either method **'Enter Current Tank Level'** or **'Enter Current Interface Level'** and type a value in the active field, then click the **'Send'** button. A confirmation popup window confirms the send is successful.

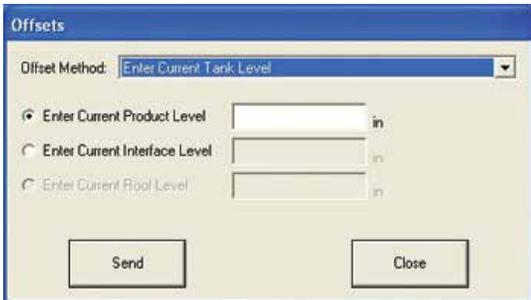

Figure 18. Offsets window - Enter Current Tank Level

When you choose **'Enter Level Offset'** from the *'Offset Method:'* drop down menu, you can adjust the offset where the transmitters zero point is located. This adjustment will significantly shorten the span of the transmitter or counter inactive zones. Adjust the value accordingly and click **'Send'**. A confirmation popup window confirms the send is successful.

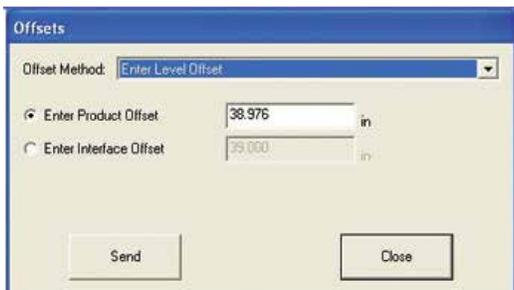

Figure 19. Offsets window - Enter Level Offset method

Address

To change the transmitter address, click the **'Address'** button in the *'Data From Device'* tab window. In the *'Change Address'* window, type the **'New Address'** in the active field and click **'Send'**. A confirmation popup window confirms the send is successful.

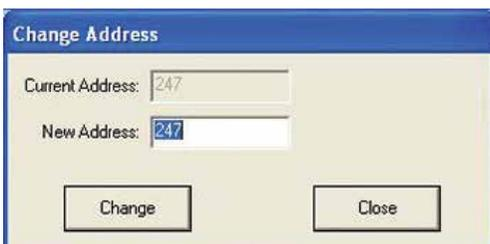

Figure 20. Change Address window - New Address entry

Backup / Restore File

If your electronics requires a replacement or if your current settings need to be refreshed, it is recommended that you create a backup or restoration file. To create a backup, click the **'Backup/Restore'** button in the *'Data From Device'* tab window. In the *'Backup and Restore Device Settings'* window, click the **'Get Data From Sensor'** button and **'Save Settings to File'** button. When prompted, save the file to a designated place where you can find it. To upload a file, click the **'Read Settings from File'** button and select your backup file. Click **'Write Data to Sensor'**. A confirmation popup window confirms the upload is successful.

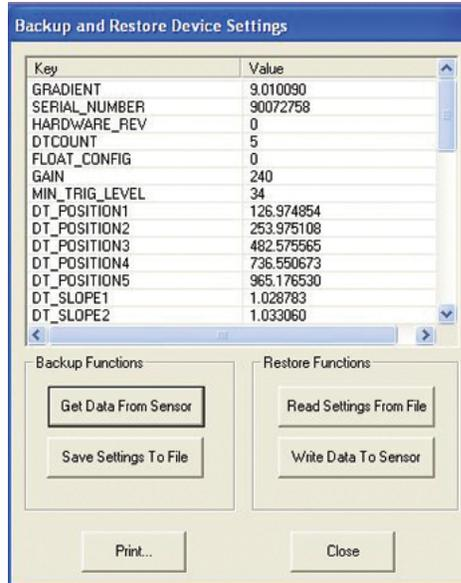

Figure 21. Backup and Restore Device Settings window

Adjust

To adjust the Gain, click the **'Adjust'** button located in the *'Data From Device'* tab window. The *'Modbus Adjust Gain'* window displays different parameter settings depending on the firmware of the transmitter. All transmitters will have the ability to adjust the *'Gain'* from this menu. Other transmitters will have the ability to adjust the gain, and display the following; magnet blanking, delta, and blanking reference. None of these parameters should be changed without *MTS Technical Support* and are password protected. ~mtsdda~

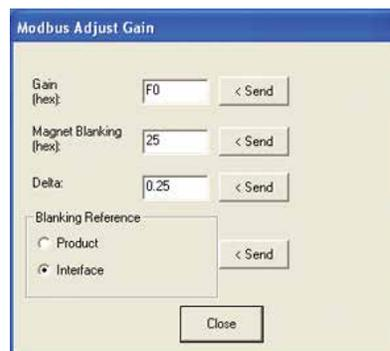

Figure 22. Modbus Adjust Gain window

Modbus User Interface

## DATA FROM DEVICE TAB (CONTINUED)

### COM Port

To select the Setup Software communication port, click the **'COM Port'** button in the *'Data From Device'* tab window. Select the appropriate communication port and click **'OK'**.

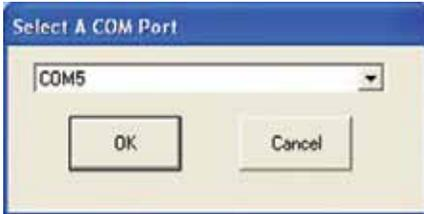

Figure 23. Select a COM Port window

## Volume Calculations tab

### Note:

As a first step always press the **'Read'** button to determine the transmitter's current configuration. After editing any parameters always press the **'Write'** button to program the transmitter.

### Correction Method

The correction method is selected by clicking the pull down menu and selecting the appropriate correction method. Available selections include 6A (Heavy Oils), 6B (Light Oils), 6C (Chemical), 6C Mod, Custom Table, and Disabled. If *'Custom Table'* is chosen, you must click **'Volume Correction Factor Table'** and enter the table.

### API Gravity

Enter the *'API gravity'* (normalized density) value for the product being measured in the applicable field. Allowable values are:

- 6A - 0.0 deg to 100.0 deg API
- 6B - 0.0 deg to 85.0 deg API

### TEC (Thermal Expansion Coefficient)

Temperature Correction Method *'6C'* uses the thermal expansion coefficient of the product being measured to determine the volume correction factor. Allowable values are 270.0 to 930.0. TEC units are in 10 E-6/deg F. In the *'TEC (6C)'* field, enter the appropriate value.

### Reference Temperature

When selecting correction method 6C Mod you will need to enter the desired base temperature for the volume calculations in the *'Reference Temperature'* field. The allowable values are 32 deg F to 150 deg F.

### Density

Entering a density is required when using Temperature Correction Method *'6C'* or *'Custom Table'* for net mass calculations. The density measurement should be entered as *'LB/cu.ft.'* at the given reference temperature.

### Volume Correction Factor Table

When Custom Table is chosen as the temperature correction method the user has to enter the volume correction factor table. The table will hold up to 50 entries of temperature points and correction fac-

### Continuous Update

To view realtime data using the Setup Software interface, select the **'Continuous Update'** box. The Interval may be changed to slow down updates but is not necessary.

### Data Logging

To download a transmitter data log, Click **'Select File'** in the *'Data From Device'* tab window. Select an Excel file and check the **'Log Data to File'** box to save your data.

tors. Once the file is created it can be saved to a file and kept on a computer for safe keeping or transferred to multiple transmitters. Before closing the user must click **'Send'** to send the VCF table to the transmitter.

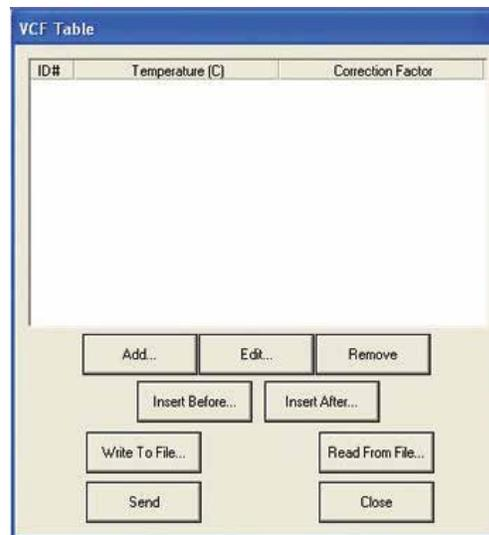

Figure 24. Volume Correction Factor Table window

### Volume Calculation Mode

Select between *'Use Sphere'* and *'Use Strap Table'* as the volume calculation mode.

### Sphere Radius

Enter the radius of the sphere the transmitter is mounted in.

### Sphere Offset

In the *'Sphere Offset'* field, enter the *'sphere offset parameter'* which is used to add or subtract a fixed volume from the calculated sphere volume. This parameter is typically used to account for volume errors created by non-uniform sphere geometry (i.e. Flat bottoms or internal structures)

## Model MG Operation and Installation Manual

### Modbus User Interface

#### VOLUME CALCULATIONS TAB (CONTINUED)

##### Working Capacity

In the working capacity field, enter the volume of safe fill level using the same units defined in the strap table. to calculate Gross Observed Volume Ullage (GOVU).

##### Average Readings

In the '*Average Ratings*' pull-down menu, select from preset averaging for the data being calculated. Selections are available from 5 to 60 seconds.

##### Strap Table

When selecting the '*Use Strap Table*' volume calculation mode the user must enter a strap table. The model MG with Modbus is capable of handling a 100 point strap table. To enter a strap table click '**Strap Table**' and click '**Add**' to start entering each volume and distance point. Once the strap table is entered save a copy to your PC by clicking '**Write to File.**' Before closing the user must click '**Send**' to send the strap table to the transmitter.

Straptable default password is 'becareful'.

## FOUNDATION™ fieldbus interface

FOUNDATION™ fieldbus is an open, integrated total architecture for information integration that is an all digital, two way communication system. A differentiator for FOUNDATION™ fieldbus is it's built in capability to distribute the control application across the network. The model MG transmitter interfaces via H1 that interconnects field devices at 31.25 kbit/s.

The H1 FOUNDATION™ Fieldbus retains and optimizes the desirable features of the 4 to 20 mA analog system such as:

- Single loop integrity
- A standardized physical interface to the wire
- Bus-powered devices on a single wire pair
- Intrinsic safety options

## Device description

The Device Description (DD) file provides information needed for a control system or host to understand the meaning of the data from the field device. DD files are platform and operating system independent so any control system or host can operate a device if it has the device's DD files. The DD files are similar to the drivers that a PC uses to operate printers, USB's, and other devices. Current DD files are available for download from <http://www.fieldbus.org>.

## Transducer block

The model MG transmitter contains two transducers blocks: *Setup* and *Factory*. All of the information and functions needed to setup, calibrate, and troubleshoot the model MG are located in the transducer blocks. Please contact Technical Support for help before changing parameters in the transducer blocks. Some of the parameters are password protected for the end users' benefit.

SETUP TRANSDUCER BLOCK		
Index	Parameter mnemonic	Description
1	ST_REV	
2	TAG_DESC	
3	STRATEGY	
4	ALERT_KEY	
5	MODE_BLK	
6	BLOCK_ERR	
7	UPDATE_EVT	
8	BLOCK_ALM	
9	TRANSDUCER_DIRECTORY	
10	TRANSDUCER_TYPE	
11	XD_ERROR	
12	COLLECTION_DIRECTORY	

SETUP TRANSDUCER BLOCK		
Index	Parameter mnemonic	Description
<i>Dynamic variables (Setup transducer block)</i>		
13	PRODUCT_LEVEL_AI	Output Level 1 (Product)
14	INTERFACE_LEVEL_AI	Output Level 2 (Interface)
15	AVERAGE_TEMPERATURE	Output Average Temp of submersed DTs (Temperature sensors)
16	NSVP	NSVP = GOVP x VCF(Volume Correction Factor)
17	GOVP	GOVP = Total Volume - Interface Volume
18	GOVI	GOVI = Interface Volume
20	TEMPERATURE1	DT 1 (Temperature sensor 1)
21	TEMPERATURE2	DT 2 (Temperature sensor 2)
22	TEMPERATURE3	DT 3 (Temperature sensor 3)
23	TEMPERATURE4	DT 4 (Temperature sensor 4)
24	TEMPERATURE5	DT 5 (Temperature sensor 5)
25	GOVT	GOVT = GOVP - GOVI
26	GOVU	GOVU = Working capacity - GOVT
27	MASS	MASS = NSVP x Density

**FOUNDATION™  
fieldbus**

**Model MG Operation and Installation Manual**  
**FOUNDATION™ fieldbus User Interface**

**FOUNDATION™  
fieldbus**

SETUP TRANSDUCER BLOCK		
Index	Parameter mnemonic	Description
<i>Setup parameters (Setup transducer block)</i>		
28	TEMP_CORR_METHOD	There are five methods to choose from: 1 = Heavy Oils 2 = Light Oils 3 = Chemicals 4 = Chemicals with wider coefficients than 6C and a movable reference temperature 5 = custom table
29	API_GRAVITY	Normalized Density value
30	WORKING_CAPACITY	Working capacity of tank
31	TEC	Thermal correction method 6C uses the thermal expansion coefficient of the product being measured to determine the volume correction factor. Allowable values are 270.0 to 930.0 TEC Units. TEC Units are in 10E-6/DegF.
32	DENSITY	Temperature correction method 6C and “custom table” requires you to enter the density (at a given reference temperature) of the product being measured.
33	REF_TEMPERATURE	This is the desired base temperature for the VCF calculation when Temperature Correction Method 4 (6C Wide) is used.
34	VOL_CALC_MODE	This is the mode you wish the volume calculations to be performed by: 1 = Use Strap Table 0 = Use Sphere Calculations
35	SPHERE_RADIUS	The radius of the sphere when volume calculations are performed (using the sphere calculation mode).
36	SPHERE_OFFSET	The offset of the sphere when volume calculations are performed (using the sphere calculation mode).
37	AVERAGE_INTERVAL	All level, temperature, and volume calculations can be averaged using timed method.
38	ALARM_STATUS	

SETUP TRANSDUCER BLOCK		
Index	Parameter mnemonic	Description
39	VCF_COR_ERR_STATUS	If there is no error performing the volume correction factor then the value is zero otherwise the value is a non-zero code.
40	VOL_CAL_ERR_STATUS	If there is no error performing the volume calculations then the value is zero otherwise the value is a non-zero code.
41	TEMP_UNITS	Celsius, Fahrenheit
42	DENSITY_UNITS	Grams per Milliliter, Grams per Liter, Kilograms per Cubic Meter, Kilograms per Liter, Pounds per Cubic Inch, Pounds per Cubic Foot, Pounds per Gallon, Metric Tonnes per Cubic Meter, Tons per Cubic Yard
43	VOLUME_UNITS	Liters, Cubic Millimeters, Cubic Meters, Cubic Inches, Cubic Feet, Gallons, or Barrels
44	LENGTH_UNITS	Millimeters, Centimeters, Meters, Kilometers, Inches, Feet, or Yards
45	MASS_UNITS	Kilograms, Grams, Ounces, Pounds, Tons, or Metric Tonnes
46	TANK_OFFSET	This is the value that will be added or subtracted from the level measurement. This allows the tank level reading to be calibrated to the users gauged tank reading (or other reference guide.)
47	INTERFACE_TANK_OFFSET	This is the value that will be added or subtracted from the interface measurement. This allows the tank interface reading to be calibrated to the users gauged tank reading (or other reference guide.)

*(Transducer block - Setup parameters continued on next page)*

SETUP TRANSDUCER BLOCK		
Index	Parameter mnemonic	Description
<i>Setup parameters (Setup transducer block) continued</i>		
48	CAL_CURRENT_PROD_LEV	This is used to calibrate the level measurement. This allows the user to enter the hand gauged tank reading (or other level reference guide) of the Product and the device will calculate the necessary calibration offset. The calculated value will then be stored as the “Tank Offset”.)
49	CAL_CURRENT_INTER_LEV	This is used to calibrate the level measurement. This allows the user to enter the hand gauged tank reading (or other level reference guide) of the Interface and the device will calculate the necessary calibration offset. The calculated value will then be stored as the “Tank Offset”.)
50	ALARM_UNITS	This parameter the unit type for which you can program the alarm. Product and Interface can be “volume” or “length” unit types, however Roof can only be “Length” unit type.
51	INTERFACE_HI_ALM	The value for which the Interface cannot be >=. Make sure that the value is programmed in the current Alarm unit type.
52	INTERFACE_LO_ALM	The value for which the Interface cannot be <=. Make sure that the value is programmed in the current Alarm unit type.
53	PRODUCT_HI_ALM	The value for which the Product cannot be >=. Make sure that the value is programmed in the current Alarm unit type.
54	PRODUCT_LO_ALM	The value for which the Product cannot be <=. Make sure that the value is programmed in the current Alarm unit type.
57	TEMP_AVR_HI_ALM	The value for which the Average Temperature cannot be >=.
58	TEMP_AVR_LO_ALM	The value for which the Average Temperature cannot be <=.

SETUP TRANSDUCER BLOCK		
Index	Parameter mnemonic	Description
59	NUM_STRAP_TAB_ENTRIES	The value specifies the number of strap table entries to be used in the tank-strapping table. Table size can range from 2 to 100 entries
60 - 63	STRAP_TAB_LEVEL	
64 - 67	STRAP_TAB_VOL	
68	NUM_VCF_TAB_ENTRIES	The value specifies the number of VCF table entries to be used in the volume correction factor table. Table size can range from 2 to 50 entries
69 - 70	VCF_TAB_TEMP	
71 - 72	VCF_TAB_CORR	

FACTORY TRANSDUCER BLOCK		
Index	Parameter Mnemonic	Description
1	1ST_REV	
2	TAG_DESC	
3	STRATEGY	
4	ALERT_KEY	
5	MODE_BLK	
6	BLOCK_ERR	
7	UPDATE_EVT	
8	BLOCK_ALM	
9	TRANSDUCER_DIRECTORY	
10	TRANSDUCER_TYPE	
11	XD_ERROR	
12	COLLECTION_DIRECTORY	
13	PASSWORD	Password, 43991
14	REG_MEAS_LENGTH	Length of the Transmitter
15	REG_SER_NO	Serial Number
16	REG_SW_REV	Software Revision
17	REG_GRADIENT	Gradient
18	REG_NUM_TEMPS	Number of DT's
19	REG_SIGNAL_GAIN	Signal Gain
20	REG_MIN_TRIG_LEVEL	Min Trigger Level
21	REG_TRANSMIT_DELAY	Transmission Delay, Always 0
22	REG_SARA_BLANKING	SARA Blanking
23	REG_MAGNET_BLANKING	Magnet Blanking
24	REG_DELTA	Delta
25	REG_MEAS_INTER-FACE_FIRST	Measure Interface First

**FOUNDATION™  
fieldbus**

FACTORY TRANSDUCER BLOCK		
Index	Parameter Mnemonic	Description
26	REG_FLOAT_CONFIG	Float Configuration
27	REG_DIG_TEMP_POS1	Digital Temp Position 1
28	REG_DIG_TEMP_INTER-CEPT1	Digital Temp Intercept 1
29	REG_DIG_TEMP_SLOPE1	Digital Temp Slope 1
30	REG_DIG_TEMP_POS2	Digital Temp Position 2
31	REG_DIG_TEMP_INTER-CEPT2	Digital Temp Intercept 2
32	REG_DIG_TEMP_SLOPE2	Digital Temp Slope 2
33	REG_DIG_TEMP_POS3	Digital Temp Position 3
34	REG_DIG_TEMP_INTER-CEPT3	Digital Temp Intercept 3
35	REG_DIG_TEMP_SLOPE3	Digital Temp Slope 3

FACTORY TRANSDUCER BLOCK		
Index	Parameter Mnemonic	Description
36	REG_DIG_TEMP_POS4	Digital Temp Position 4
37	REG_DIG_TEMP_INTER-CEPT4	Digital Temp Intercept 4
38	REG_DIG_TEMP_SLOPE4	Digital Temp Slope 4
39	REG_DIG_TEMP_POS5	Digital Temp Position 5
40	REG_DIG_TEMP_INTER-CEPT5	Digital Temp Intercept 5
41	REG_DIG_TEMP_SLOPE5	Digital Temp Slope 5
42	REG_TRIGGER_LEV0	
43	REG_TRIGGER_LEV1	
44	REG_TRIGGER_LEV2	
45	REG_TRIGGER_LEV3	
46	NUM_TEMP_AVR_HI	Num Temp Average

### Analog input function blocks

The Model MG transmitter contains 6 Analog Inputs with the output options of product, interface, average temperature, NSVP, GOVP, and GOVI. The Interface and GOVI Analog Inputs require the transmitter to be configured for measuring product and interface levels. To perform a quick configuration of the function blocks configure the following:

#### Channel

Analog Input	Channel #	Units
Product	1	Length units
Interface	2	Length units
Average Temperature	3	Temperature units
NSVP	4	Volume units
GOVP	5	Volume units
GOVI	6	Volume units

#### Linearization Type

<b>Direct</b>	Choose direct when the output is the transmitter's value.
<b>Indirect</b>	Choose indirect when the output is calculated based off of the transmitter's value and the relationship is linear, i.e. 0 to 100%
<b>Indirect Square Root</b>	Choose indirect square root when the output is calculated based off of the transmitter's and the output is the square root of the transmitter's value.

#### Transducer Scale and Output Scale

<b>Direct</b>	Transducer Scale and Output Scale do not need to be configured.
<b>Indirect or Indirect Square Root</b>	The transducer scale should be set to the full operating range that the transmitter will see during use. The output scale should contain the values that would be outputted when the transducer scale is at its minimum and maximum. The relationship is linear.

The *Transducer Scale* and *Output Scale* can also be configured to display in set units and with a set number of significant digits.

*Transducer Scale* units will be the same as the units programmed into the transmitter; the default settings are *Inches* for length, *Fahrenheit* for temperature, and *Gallons* for volume. Units can be changed under **MTS\_SETUP\_TB** -> **Setup Parameters** -> **Data from device** -> **Units**. It is best to double check the units in the transmitter and the Transducer Scale incase someone has changed them accidentally.

#### Example 1: Output of product level

Parameter	Configured Value
Channel	1 - Product
Linearization Type	Direct
Transducer Scale: EU at 100%	N/A
Transducer Scale: EU at 0%	N/A
Transducer Scale: Units Index	N/A
Transducer Scale: Decimal	N/A
Output Scale: EU at 100%	N/A
Output Scale: EU at 0%	N/A
Output Scale: Units Index	N/A
Output Scale: Decimal	N/A

#### Example 2: Output of Product Level in Percent for 10 m (33 ft.) Transmitter

Parameter	Configured Value
Channel	1 - Product
Linearization Type	Indirect
Transducer Scale: EU at 100%	396
Transducer Scale: EU at 0%	0
Transducer Scale: Units Index	In
Transducer Scale: Decimal	3
Output Scale: EU at 100%	100
Output Scale: EU at 0%	0
Output Scale: Units Index	%
Output Scale: Decimal	3

## Resource block

The Resource Block describes characteristics of the Fieldbus device such as the device name, manufacturer, and serial number. A device has only one Resource Block.

## LAS/Back-up LAS

The model MG transmitter is designed as a Link Master and can be used as a primary or secondary Link Active Scheduler (LAS). For the majority of networks the host system will be the primary LAS with a field device acting as secondary LAS in the event that the primary LAS fails. The typical use of the model MG transmitter will be as a secondary LAS for back-up.

## Setup and calibration

Setup and Calibration can be conducted from any host with a different process. Below are common parameters that will need to be changed. Please consult the Transducer Block section to locate the parameters. Specific parameters are password protected to keep users from accidentally changing factory parameters that should not be changed unless advised by Technical Support.

### Note:

The mode will have to be changed to Out of Service (OOS) when editing parameters. When making this change most host systems will warn you that this may upset the process and create a dangerous situation in your plant. Before making the change to OOS, verify that taking the transmitter out of service will not negatively affect control of the plant.

## UNITS

The model MG transmitter allows the user to select the units for length, temperature, volume, mass, and density.

<b>TEMP_UNITS</b>	Celsius, Fahrenheit
<b>DENSITY_UNITS</b>	Grams per Milliliter, Grams per Liter, Kilograms per Cubic Meter, Kilograms per Liter, Pounds per Cubic Inch, Pounds per Cubic Foot, Pounds per Gallon, Metric Tonnes per Cubic Meter, Tons per Cubic Yard
<b>VOLUME_UNITS</b>	Liters, Cubic Millimeters, Cubic Meters, Cubic Inches, Cubic Feet, Gallons, or Barrels
<b>LENGTH_UNITS</b>	Millimeters, Centimeters, Meters, Kilometers, Inches, Feet, or Yards
<b>MASS_UNITS</b>	Kilograms, Grams, Ounces, Pounds, Tons, or Metric Tonnes

## CALIBRATION

Calibration can be done either using the current tank level or entering an offset for both the product and interface level. The TANK\_OFFSET and INTERFACE\_TANK\_OFFSET contain values that adjust the reference point for the zero point on the transmitter. By adjusting the offsets up or down the user can change the value the transmitter outputs. This process is harder than it sounds and Technical Support should be contacted before proceeding.

An alternative method of calibration is to use CAL\_CURRENT\_PROD\_LEV and CAL\_CURRENT\_INTER\_LEV to calibrate the product and interface levels respectively. In order to do so the tank should be static and the user can hand gauge the tank. The user can then take the hand gauge measurement and input it into the transmitter. Make sure that the level does not move from the time the measurement is taken until the transmitter is calibrated. The transmitter will take the current level that is entered and calculate the offsets for the user.

## VOLUME CALCULATION

The model MG will calculate the volume of the vessel using either a sphere or a strap table formula. The user can choose which method by selecting a 1 for Strap Table or a 0 for a Sphere under VOL\_CALC\_MODE. When selecting to use the Sphere method the user will have to enter the SPHERE\_RADIUS and SPHERE\_OFFSET. Despite which method is chosen, the user should enter the WORKING\_CAPACITY and AVERAGE\_INTERVAL.

When the user selects to calculate volume based off of a strap table the user will need to enter the strap table. The first step is to enter the NUM\_STRAP\_TAB\_ENTRIES between 2 and 100. For each strap table point the user will have to enter the STRAP\_TAB\_LEVEL and STRAP\_TAB\_VOL for every entry.

## TEMPERATURE CORRECTION METHOD

The TEMP\_CORR\_METHOD is selected by selecting the appropriate correction method.

Available selections include:

- 1 = 6A (Heavy Oils)
- 2 = 6B (Light Oils)
- 3 = 6C (Chemical)
- 4 = 6C Mod
- 5 = Custom Table

If Custom Table is chosen the user will need to enter the NUM\_VCF\_TAB\_ENTRIES.

Enter the API\_GRAVITY (normalized density) value for the product being measured in the applicable field. Allowable values are:

- 6A - 0.0 deg to 100.0 deg API
- 6B - 0.0 deg to 85.0 deg API

TEC (Temperature Correction Method) 6C uses the thermal expansion coefficient of the product being measured to determine the volume

## Model MG Operation and Installation Manual

### FOUNDATION™ fieldbus User Interface

correction factor. Allowable values are 270.0 to 930.0. TEC units are in 10 E-6/deg F. In the TEC (6C) field, enter the appropriate value.

When selecting correction method 6C Mod you will need to enter the desired base temperature for the volume calculations in the REF\_TEMPERATURE. The allowable values are 32 deg F to 150 deg F.

Entering a DENSITY is required when using Temperature Correction Method 6C or Custom Table for net mass calculations. The density measurement should be entered as LB/cu.ft. at the given reference temperature.

When the user selects to calculate temperature correction based off of a custom table the user will need to enter the custom table. The first step is to enter the NUM\_VCF\_TAB\_ENTRIES between 2 and 50. For each custom table point the user will have to enter the VCF\_TAB\_TEMP and VCF\_TAB\_CORR for every entry.

### FOUNDATION fieldbus handheld menu tree

---

#### MTS\_SETUP\_TB

##### FB dynamic variables

##### Other dynamic variables

##### Alarm Status

- Alarm Status
- VCF Calc Error Status
- Volume Calc Error

##### Setup Parameters

- Data from device

##### Units

- Length Units
- Temperature Units
- Volume Units
- Mass Units
- Density Units

##### Alarms

##### Offsets

- Enter Product Offset
- Enter Interface Offset
- Enter Current Product Level
- Enter Current Interface Level

- Volume Calculations

##### Temperature Correction Methods

- Temperature Correction Method
- API Gravity
- TEC (6C)
- Ref Temperature (6C Mod)
- Density
- Custom Table
  - Num of VCF table entries
  - Enter Custom Table
    - VCF Corr Table: Temperature
    - VCF Corr Table: Correction Factor

##### Volume Calculations

- Mode
- Working Capacity
- Average Interval

#### MTS\_FACTORY\_TB

##### Password

##### Settings

- Gradient
- Serial Number
- Software Revision
- Number of DT's
- Signal Gain
- Min Trigger Levels
- Transmission Delay
- SARA Blanking
- Magnet Blanking
- Delta
- Measure Interface First

##### Digital Temperature Setup

- Number of DT's
- Enter Temperature Points

##### Float Configuration

##### Set Trigger Levels

## DDA interface

### Data line termination and biasing:

Termination and biasing of RS-485 data lines are as follows:

- Biasing**  
 Each M-Series transmitter has internal high impedance biasing resistors (30K  $\Omega$ ) on both RS-485 data lines. No additional biasing resistors should be present on the connecting devices (PLC, DCS, PC, converter).
- Termination**  
 Each M-Series transmitter has an internal termination resistor (100K  $\Omega$ ) installed across the RS-485 signal lines. No additional termination resistors are necessary in the connecting devices (PLC, DCS, PC, converter).

### Communication parameters:

The 2-wire differential communication interface and all data transmissions must be at half duplex. Only one device (either the master or a single transmitter) can transmit data at any given time. BAUD rate limitations are listed below.

<b>Modbus:</b>	4800 or 9600 BAUD	8, N, 1
<b>DDA:</b>	<b>4800 BAUD</b>	<b>8, E, 1</b>
(Reference) Monitor:	Modbus RTU Variable BAUD Rate	8, E, 1

## Hardware and software environments

The Level Plus Model MG digital transmitter operates in a networked, intrinsically safe RS-485 DDA software environment. This environment supports up to 8 multi-dropped transmitters on one communication line. The network requires a 4-wire bus to provide both power and communications to each of the transmitters located in the hazardous area. The transmitters are connected in multi-point configuration (see Figure 25).

The RS-485 network operates in a master/slave mode where the master (host computer or similar type network controller) interrogates each slave (DDA transmitter) for a specific type of data. Each slave has a unique switch programmable hardware address that is issued

by the host computer to activate a particular transmitter. In addition, the DDA hardware supports a command decoder that supports up to 128 different commands. The host computer interrogates a transmitter for data by sending an address byte, followed immediately by a command byte. The addressed transmitter will 'wake up', identify itself by transmitting an echo of its own local address followed by the received command, and then perform the requested action. After the requested action has been completed, the data (if any) will be transmitted back to the host computer on the RS-485 network. Refer to Section 'DDA Command decoder examples' on page 43 for more information.

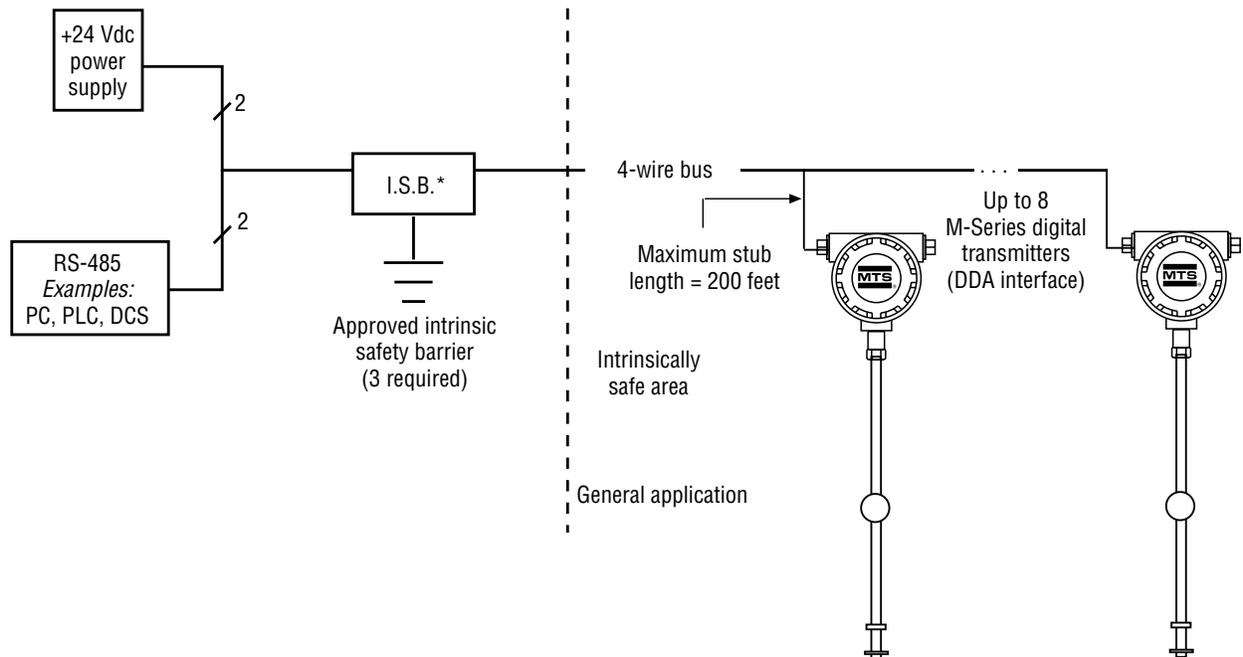
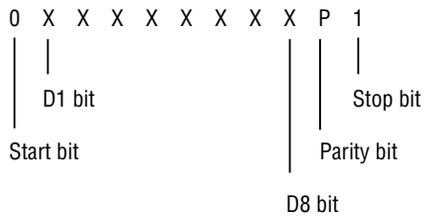

Figure 25. Typical Electrical Connections - Intrinsically Safe System

## DDA command decoder examples

### SERIAL DATA TRANSMISSION FORMAT

Example 1:



After the DDA address decoder circuitry receives the 11-bit word, an even parity check is performed across the 8-bit data field. If a parity error is found, the word is ignored and the decoder circuitry resets for the next transmission. If the parity check is good, the decoder circuitry checks for a valid address byte. The address decoder circuitry uses the 'D8' bit to distinguish the difference between address bytes and command bytes. Address bytes are defined as having the most significant bit 'D8' set equal to one. Valid address byte values include 'C0' hex to 'FD' hex (192 to 253 decimal). Address byte values from 80 hex to 'BF' hex are reserved for future use, address byte values 'FE' and 'FF' hex are reserved for test functions. (see Example 2).

### ADDRESS BYTE

Example 2:

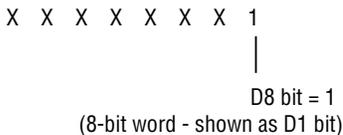

If the received address byte matches the local DDA address, the DDA power supply circuitry is activated. If a valid address byte has been command.

## DDA/Host computer communication protocol

The DDA/Host computer communication protocol consists of two parts: the interrogation sequence generated by the host computer and the data response generated by the interrogated DDA transmitter. The host interrogation sequence always consists of an address byte followed immediately by a command byte (see Example 4).

### DDA/HOST COMMUNICATION

Example 4:

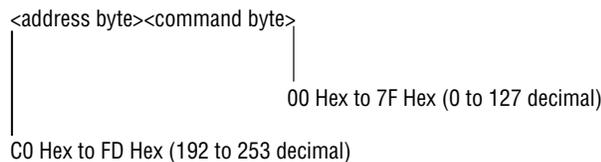

The maximum delay between the address byte and the command byte is 5 milliseconds. The DDA transmitter will not receive the new command byte if this delay period is exceeded (and the old command byte will be left in the command buffer). See previous section for additional information on verification of the Address/Command bytes. An example of an interrogation sequence to access a transmitter programmed for address 'F0' hex (see Example 5).

The transmitter response consists of several components. After a transmitter has been interrogated, the transmitter first responds by

found, the decoder circuitry checks to see if the next received word is a command byte. Valid command byte values include '00' hex to '7F' hex (0 to 127 decimal). In addition, all data byte values are restricted to be within '00' hex and '7F' hex (see Example 3).

### COMMAND BYTE (AND DATA BYTES)

Example 3:

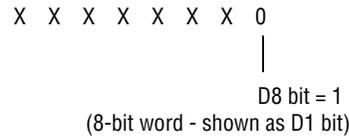

Again, an even parity check is performed on the command byte. If the parity check is good, the eight bit data word is latched into a command buffer. This buffer is read by the DDA software to determine which command to execute. If the parity check fails, the command byte is rejected and the old command (from the previous interrogation sequence) will be left in the command buffer. The DDA hardware cannot determine if the current command was possibly rejected. The host computer must then verify if the correct command was received by reading the echo of the address byte and command byte sent by the DDA transmitter. This is the only guaranteed way to determine that both the address and command bytes were received properly.

This method also insures proper verification, even if the parity check fails to detect a multiple bit data error in either the address byte or command byte. If the host computer determines that either the address byte or command byte has been corrupted, it must wait the proper time-out period and ignore the received message from the DDA transmitter that was improperly interrogated. The time-out period is variable and is based on the duration of the selected DDA

transmitting its own local address and the command that was received from the host computer. This re-transmission of the transmitter address and received command serves two purposes. The first being a simple identification that the correct transmitter received the correct command and that it is currently active. The second purpose is to reset the DDA Address/Command decoder circuitry for the next interrogation sequence.

### INTERROGATION DATA SEQUENCE

Example 5:



#### Note:

If the DDA transmitter does not respond to the first interrogation by the host, the Address/Command decoder will be left in an intermediate state. If this occurs, the host will have to reinterrogate the respective transmitter to reset the Address/Command decoder circuitry and then interrogate the respective transmitter again to perform a new transmitter measurement. This hardware feature must be considered when writing software communication drivers to access DDA transmitter data.

## DDA/Host computer communication protocol (Continued)

After the DDA transmitter has retransmitted its local address and received command, it will perform the requested measurement as defined by the received command. After the requested measurement has been completed, the data for that measurement will be transmitted to the host in a predefined format including certain control characters. The DDA transmitted data format begins with a 'start of text' '**STX**' character (STX = 02 hex). The '**STX**' character set is immediately followed by the requested data and then terminated with an 'end of text' '**ETX**' character set (ETX = 03 hex). Certain commands allow multiple data fields to be transmitted within one transmitted data sequence. For these data transmissions, each data field is separated by an ASCII colon ':' character (: = 3A hex), (see Examples 6 and 7).

### Single field data transmission

Example 6:

```
<STX><ddd.d><ETX>
```

### Multiple field data transmission

Example 7:

```
<STX><ddd.d:ddd.d:ddd.d><ETX>
```

All transmitted data will consist of 7-bit ASCII characters limited to hex values between '**00**' hex and '**7F**' hex (i.e. data bit D8 = 0).

After a DDA transmitter has completed a data transmission, the host must wait 50 milliseconds before another interrogation can be performed. This delay is required to enable the previously interrogated transmitter to go into sleep mode and release the network communication lines.

All DDA control commands support a checksum calculation function, *Data Error Detection* (DED) that allows the host computer (master) to check the integrity of the transmitted data. The actual checksum value that is transmitted is the compliment (2's compliment) of the calculated value. The checksum scheme is based on a 16-bit summation of the hex data within the transmitted block (including '**STX**' and '**ETX**' character sets) without regard to overflow. The two byte result of the adding process is then complimented and appended to the transmitted data block.

This compliment process makes the final checksum comparison more efficient in that the checksum result added to its compliment will always result in a zero sum for uncorrupted data transmissions. Checksum data (two hex bytes) can range from '**0000**' hex to '**FFFF**' hex. Since the communication network only allows transmitted data values between '**00**' and '**7F**' hex, special processing is required on the hex checksum value before it can be transmitted.

This two byte hex value must first be converted to numeric (decimal) ASCII characters before transmission. For example, a checksum value of '**FFFF**' hex would be transmitted as *ASCII 65535*. The host computer would then have to convert ASCII 65535 back to FFFF hex and perform its own checksum calculation and comparison for the received data from the DDA transmitter. An example is shown (see Example 8) of a single field data transmission including checksum data and a sample checksum calculation.

### Checksum calculation

Example 8:

```
<STX><ddd.d><ETX><cccc>
                                     |
                                     v
                               Append checksum value
```

#### Note:

The appended checksum value will always consist of five decimal (ASCII) characters ranging from 00000 to 65535. The checksum function can be enabled or disabled.

Message transmitted from DDA transmitter (command 12 Hex):

```
<STX><265.322.109.456><ETX>64760
```

Hex character equivalent of transmitted data record including <STX> and <ETX> characters:

```
02, 32, 36, 35, 2E, 33, 32, 32, 3A, 31, 30, 39, 2E, 34, 35, 36, 03
```

Two byte Hex summation of data:

0308 Hex

Two's compliment:

FCF8 Hex

Convert to decimal ASCII:

64760

To verify transmitted data from the DDA transmitter, perform the two byte Hex summation over the data record (including '<STX>' and '<ETX>') shown in (Example 8). The result in this example is 0308 Hex. Then convert the decimal ASCII checksum value back to Hex (for example, 64760 to FCF8 Hex). Add the Hex summation value to the Hex checksum value and the result will be zero (disregarding overflow) for uncorrupted data. 0308 Hex + FCF8 Hex = 0000 Hex.

#### Note:

Cyclic Redundancy Check (CRC) error checking will be offered at a later date. A command switch will be defined that will let the DDA data be transmitted with CRC error checking instead of checksum error checking. The checksum calculations will use the CRC-CCITT defined polynomial with a 16-bit CRC result. This 16-bit CRC value will be appended to each transmitted message. Since the communication network only allows transmitted data values between 00 and 7F hex, special processing is required on the 16-bit hex CRC value before it can be transmitted. This 16-bit (two byte) hex value must first be converted to numeric (decimal) ASCII characters before transmission. For example, a checksum value of '**FFFF**' hex would be transmitted as *ASCII 65535*.

NETWORK PROTOCOL/TIMING CONSIDERATIONS

The DDA network has several timing constraints that must be considered when designing and coding communication drivers. The DDA network follows the RS-485 standard which defines a multi-drop communication interface that uses differential drivers and receivers operating in half-duplex mode. When using the RS-485 standard configuration, each device's driver and receiver are wired together (see Figure 26).

Each device drive on the network must be disabled (high impedance) except when the device is ready to transmit data. In order to keep devices from transmitting data at the same time, one device is selected as the host (or master). In a DDA network, the host computer (or other communication interface) is the master, and controls the communication timing and protocol. The DDA transmitters act as slave devices, only transmitting data when requested by the host computer device. In this case, the host computer enables its driver and transmits the 'Address/Command' interrogation sequence.

After the Address/Command has been completely transmitted, the host disables its driver to allow reception of the data from the DDA transmitter. The transmitter with the matching address then becomes active, enables its driver and transmits the Address/Command echo followed by the requested data. The transmitter then disables its driver and goes back into sleep mode. Since all devices operate independently, certain timing constraints are imposed on the protocol to eliminate multiple devices from transmitting data simultaneously.

Network protocol timing sequences (interrogation sequences) are shown in (Figure 27). This time line representation of data transmission sequences also provides information about host computer control of the RS-485 communication card and also illustrates driver enabled control through the RTS control line.

The following steps provide an interrogation sequence example:

1. The start of the sequence begins when the host enables its RS-485 driver to transmit the Address/Command bytes (see time line 'T0' in Figure 27).
2. After the driver is enabled, the host performs a small time delay 'T1'. In this example, the host enables the driver by raising the RTS control line of the computer to the active (enabled) state. This typically requires no more than 1 millisecond. If the communication lines are extremely long, additional time may be required due to the additional capacitance of the wires.
3. The host then transmits the address byte followed immediately by the command byte. For 4800 Baud transmission rates, the time to transmit one byte (11-bit word size) is fixed at 2.3 milliseconds. Then time delays 'T2' and 'T4' are fixed at 2.3 milliseconds. Time delay 'T3' is the interbyte transmission time. Normally this is at least one bit time

Note:

Many available communication cards (line drivers) for use with the host computer device use a special control line input to control the enabling and disabling of the RS-485 driver. Typically this input is connected to the computers RTS or DTR communication port control line. The computer can then control the state of the driver by toggling the RTS or DTR signal lines via software control. An example of this control method is shown in (Figure 27). Other control methods are also used depending on the manufacturer of the equipment.

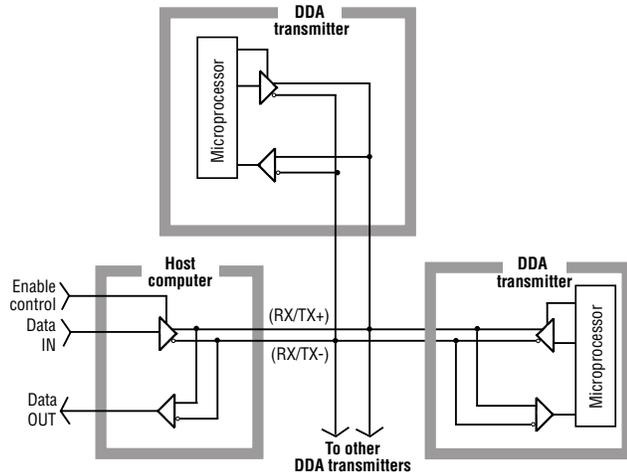

Figure 26. RS-485 Multi-drop example

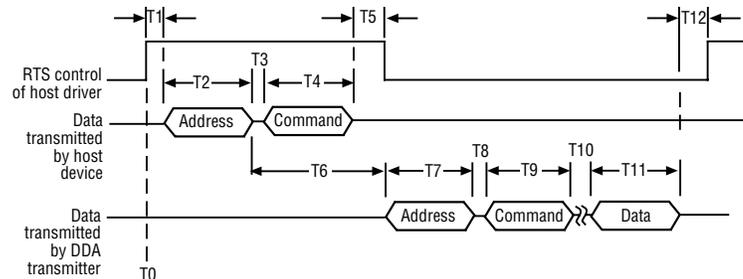

Figure 27. Network protocol timing information

4. After the host transmits the address and command bytes, the host disables its driver to allow the transmitter to transmit the Address/Command echo and the requested data. Before the driver is disabled, the software must insure that the command byte has been completely transmitted. This can be done by observing control flags from 'UART' of the communication port, such as Transmit Register Empty (TRE) and Transmit Holding Register Empty (if the UART is double buffered). Software delay methods based on maximum character transmission times for 4800 Baud rates can also be

### Interrogation sequence examples (Continued)

used but are less reliable. Once it has been verified that the command byte '0' has been completely transmitted, an additional delay should be added before the driver is disabled.

This delay 'T5' will insure that data has propagated the network wiring before the driver goes to the high impedance (disabled) state. A delay period of 'T5' = 1 millisecond is adequate for most long cable runs. The maximum delay allowed for 'T5' is based on the fact that time period 'T6' is fixed in the DDA hardware to be 22 (+/-2) milliseconds. The host driver should be disabled well before (at least 5 milliseconds) the DDA transmitter enables its driver and begins transmission of the Address/Command echo. Assuming the maximum delay of 5 milliseconds for period 'T3', and 2.3 milliseconds for 'T4', and that the host driver should be disabled for 5 milliseconds before the transmitter begins transmitting data, the maximum delay for 'T5' then is 7.7 milliseconds.

**Note:**

If 'T3' is less than 5 milliseconds, then the maximum delay for 'T5' can be extended by the difference (5 milliseconds - T3 actual).

5. The transmitter will begin to transmit the Address/Command echo in 22 (+/- 2) milliseconds after the address byte is received from the host computer. This is defined as period 'T6' and is fixed by the DDA hardware. Based on a Baud rate of 4800, the address echo is transmitted in 2.3 milliseconds (period 'T7'). The interbyte delay period 'T8' for the DDA transmitter is fixed at 0.1 milliseconds and the command echo is transmitted 2.3 milliseconds (period 'T9').
6. Period 'T10' is the time required for the DDA electronics to perform the requested command. This is a variable

delay based on the command requested. The typical transmitter response time for each command is listed in section '11.4 DDA command definitions'.

7. Period 'T11' is the time required for the DDA electronics to transmit the data for the requested command. This is a variable delay based on the command requested. The typical data transmission time for each command is listed in section '11.4 DDA command definitions'.
8. After the transmitter has completed the data transmission for the requested command, it will disable its driver and go back to inactive mode. The transmitter electronics require 50 milliseconds to transition from active mode to inactive mode. Another transmitter (or the same transmitter) cannot be interrogated until time period 'T12' = 50 milliseconds has elapsed.
9. Repeat the sequence for the next transmitter.

### Other protocol considerations

1. The transmitted ASCII data from the DDA transmitter may contain data fields with 'Exxx' error codes. All DDA error codes are preceded by ASCII 'E' (45 hex, 69 decimal). Communication interface drivers must parse and handle DDA error codes properly or data processing errors could result. For additional information about DDA error codes, (see page 54).
2. Use the DDA 'Data Error Detection' function to verify the integrity of the data transmitted from the transmitter.
3. Certain RS-485 communication cards and (RS-232 to RS-485 converter cards) allow user control of the receiver function. This feature must be considered when developing communication drivers. Due to the half-duplex RS-485 loopback wire connections, all data that is transmitted by the host computer device will be 'echoed' into the receiver inputs. If the receiver function is enabled, then the host transmitted data along with the DDA transmitter transmitted data will be received into the computer receive buffer.

## DDA Command definitions (includes protocol information)

### SPECIAL CONTROL COMMANDS

#### Command 00 Hex (0 Dec) - Transmitter disable command

This command can be used to disable an active transmitter (force transmitter back to sleep mode). This command does not need to be preceded by an address byte and can only be issued when DDA transmitters are not transmitting data. This 'disabled' command is typically used with other commands that could leave the transmitter in active mode, i.e. certain memory transfer commands, test mode commands, etc.

**Note:**

During normal mode operation, a DDA transmitter will force itself back into sleep mode if any data is transmitted on the network by any other device. This is a safety feature added to the firmware to avoid data collisions on the network.

#### Command 01 Hex (1 Dec): Module identification command

**Data format:** <STX><DDA><ETX><cccc>

- Fixed length record containing 3 ASCII characters '<DDA>'
- Five (5) character checksum appended after '<ETX>' character set

#### Command 02 Hex (2 Dec): Change address

**Data format:** <SOH><ddd><EOT>

- Fixed length record with three (3) characters
- The data field is the new address
- The data range is the new address
- The data range is from 192 - 253
- '<SOH>' is ASCII 01 Hex
- '<EOT>' is ASCII 04 Hex
- Default Address is '192'

#### Command 03 Hex - Command Hex 09 - Not Defined

LEVEL COMMANDS

**Command 0A Hex (10 Dec):** *Output level 1 (product) at 0.1 inch resolution (with checksum)*

- Data format:** <STX><dddd.d><ETX><cccc>
- Variable length record with one (1) to four (4) characters to the left of decimal character
  - Fixed at one (1) character to the right of decimal character
  - Five (5) character checksum appended after the '<ETX>' character set

**Note:**  
 <cccc> Checksum characters are only appended if the Data Error Detection (DED) function is enabled.

**Command 0B Hex (11 Dec):** *Output level 1 (product) at 0.01 inch resolution (with checksum)*

- Data format:** <STX><dddd.dd><ETX><cccc>
- Variable length record with one (1) to four (4) characters to the left of decimal character
  - Fixed at two (2) characters to the right of decimal character
  - Five (5) character checksum appended after the '<ETX>' character set

**Command 0C Hex (12 Dec):** *Output level 1 (product) at 0.001 inch resolution (with checksum)*

- Data format:** <STX><dddd.ddd><ETX><cccc>
- Variable length record with one (1) to four (4) characters to the left of decimal character
  - Fixed at three (3) characters to the right of decimal character

**Data characters can include the following:**

- 0 through 9
- (-) minus sign
- (.) decimal point
- (E) ASCII 45 Hex precedes all error codes
- (:) ASCII 3A Hex is used as a data field separator for multiple data field transmissions
- (space) ASCII 20 Hex space character

**Command 0D Hex (13 Dec):** *Output level 2 (interface) at 0.1 inch resolution (with checksum)*

**Data format:** Same as Command 0A

**Command 0E Hex (14 Dec):** *Output level 2 (interface) at 0.01 inch resolution (with checksum)*

**Data format:** Same as Command 0B

**Command 0F Hex (15 Dec):** *Output level 2 (interface) at 0.001 inch resolution (with checksum)*

**Data format:** Same as Command 0C

**Command 10 Hex (16 Dec):** *Output level 1 (product) and level 2 interface at 0.1 inch resolution (with checksum)*

- Data format:** <STX><dddd.d.ddd.d><ETX><cccc>
- Variable length record with one (1) to four (4) characters to the left of each decimal character in each data field
  - Fixed at one (1) character to the right of each decimal character in each

data field

- Level 1, level 2 data fields separated by ASCII colon (:) character
- Five (5) character checksum appended after the '<ETX>' character set

**Command 11 Hex (17 Dec):** *Output level 1 (product) and level 2 (interface) at 0.01 inch resolution (with checksum)*

**Data format:** <STX><dddd.dd.ddd.dd><ETX><cccc>

- Variable length record with one (1) to four (4) characters to the left of each decimal character in each data field
- Fixed at two (2) characters to the right of each decimal character in each data field.
- Level 1, level 2 data fields separated by ASCII colon (:) character
- Five (5) character checksum appended after the '<ETX>' character set

**Command 12 Hex (18 Dec):** *Output level 1 (product) and level 2 (interface) at 0.001 inch resolution (with checksum)*

**Data format:** <STX><dddd.ddd.ddd.ddd><ETX><cccc>

- Variable length record with one (1) to four (4) characters to the left of each decimal character in each data field
- Fixed at three (3) characters to the right of each decimal character in each data field
- Level 1, level 2 data fields separated by ASCII colon (:) character
- Five (5) character checksum appended after the '<ETX>' character set

**Command 13 Hex - Command 18 Hex - Not Defined**

TEMPERATURE COMMANDS

**Command 19 Hex (25 Dec):** *Average Temperature at 1.0 °F resolution (with checksum)*

**Data format:** <STX><dddd><ETX><cccc>

- Variable length record with one (1) to four (4) characters
- Five (5) character checksum appended after the '<ETX>' character set

**Note:**  
 Average temperature is the average temperature reading from all DTs submerged by approximately 1.5 inches of product.

**Command 1A Hex (26 Dec):** *Average temperature at 0.2 °F resolution (with checksum)*

**Data format:** <STX><dddd.d><ETX><cccc>

- Variable length record with one (1) to four (4) characters to the left of decimal character
- Fixed at one (1) character to the right of decimal character
- Five (5) character checksum appended after the '<ETX>' character set

**Command 1B Hex (27 Dec):** *Average temperature at 0.02 °F resolution (with checksum)*

**Data format:** <STX><dddd.dd><ETX><cccc>

- Variable length record with one (1) to four (4) characters to the left of decimal character
- Fixed at two (2) characters to the right of decimal character
- Five (5) character checksum appended after the '<ETX>' character set

## TEMPERATURE COMMANDS (CONTINUED)

### Command 1C Hex (28 Dec):

*Individual DT temperature at 1.0 °F resolution (with checksum)*

#### Data format:

`<STX><dddd:dddd:dddd:dddd:dddd><ETX><cccc>`

- Variable length record with one (1) to four (4) characters in each data field
- Variable number of data fields (up to 5) separated by ASCII colon (:) characters. Number of data fields is based on the number of DTs programmed in DDA transmitter memory
- First data field is always DT #1, second data field is DT #2, etc
- Five (5) character checksum appended after the '<ETX>' character set

### Command 1D Hex (29 Dec):

*Individual DT temperature at 0.2 °F resolution (with checksum)*

#### Data format:

`<STX><dddd.d:dddd.d:dddd.d:dddd.d:dddd.d><ETX><cccc>`

- Variable length record with one (1) to four (4) characters to the left of decimal character in each data field
- Fixed at one (1) character to the right of each decimal character in each data field
- Variable number of data fields (up to 5) separated by ASCII colon (:) characters. Number of data fields is based on the number of DTs programmed in DDA transmitter memory
- First data field is always DT #1, second data field is DT #2,...etc
- Five (5) character checksum appended after the '<ETX>' character set

### Command 1E Hex (30 Dec):

*Individual DT temperature at 0.02 °F resolution (with checksum)*

#### Data format:

`<STX><dddd.dd:dddd.dd:dddd.dd:dddd.dd:dddd.dd><ETX><cccc>`

- Variable length record with one (1) to four (4) characters to the left of decimal character in each data field
- Fixed at two (2) characters to the right of each decimal character in each data field
- Variable number of data fields (up to 5) separated by ASCII colon (:) characters. Number of data fields is based on the number of DTs programmed in DDA transmitter memory
- First data field is always DT#1, second data field is DT #2,...etc
- Five (5) character checksum appended after the '<ETX>' character set

### Command 1F Hex (31 Dec):

*Average and individual DT temperature at 1.0 °F resolution (with checksum).*

#### Data format:

`<STX><dddd:dddd:dddd:dddd:dddd:dddd><ETX><cccc>`

- Variable length record with one (1) to four (4) characters in each data field
- Variable number of data fields (up to 6) separated by ASCII colon (:) characters. The number of data fields is based on the number of DTs programmed in DDA transmitter memory (number of DTs + 1)
- The first data field is always the average of the individual DTs submerged by at least 1.5 inches of product
- The second data field is always DT #1, third data field is DT #2, ... etc
- Five (5) character checksum appended after the '<ETX>' character set

### Command 20 Hex (32 Dec):

*Average and individual DT temperature at 0.2 °F resolution (with checksum).*

#### Data format:

`<STX><dddd.d:dddd.d:dddd.d:dddd.d:dddd.d><ETX><cccc>`

- Variable length record with one (1) to four (4) characters to the left of decimal character in each data field
- Fixed at one (1) character to the right of each decimal character in each data field
- Variable number of data fields (up to 6) separated by ASCII colon (:) characters. The number of data fields is based on the number of DTs programmed in DDA transmitter memory (number of DTs + 1)
- The first data field is always the average of the individual DTs submerged by at least 1.5 inches of product
- The second data field is always DT #1, third data field is DT #2, ... etc
- Five (5) character checksum appended after the '<ETX>' character set

### Command 21 Hex (33 Dec):

*Average and individual DT temperature at 0.02 °F resolution (with checksum).*

#### Data format:

`<STX><dddd.dd:dddd.dd:dddd.dd:dddd.dd:dddd.dd><ETX><cccc>`

- Variable length record with one (1) to four (4) characters to the left of decimal character in each data field
- Fixed at two (2) characters to the right of each decimal character in each data field
- Variable number of data fields (up to 6) separated by ASCII colon (:) characters. The number of data fields is based on the number of DTs programmed in DDA transmitter memory (number of DTs + 1)
- The first data field is always the average of the individual DTs submerged by at least 1.5 inches of product
- The second data field is always DT #1, third data field is DT #2, ... etc
- Five (5) character checksum appended after the '<ETX>' character set

### Command 22 Hex - Command 24 Hex - Reserved

### Command 25 Hex (37 Dec):

*Fast average and individual DT temperature at 1.0 °F resolution (with checksum)*

#### Data format:

*Same as command 1F Hex*

### Command 26 Hex - Command 27 Hex - Not defined

## MULTIPLE OUTPUT COMMANDS (LEVEL AND TEMPERATURE)

### Command 28 Hex (40 Dec):

*Level 1 (product) at 0.1 inch resolution, and average temperature at 1.0 °F resolution (with checksum)*

#### Data format:

`<STX><dddd.d:dddd><ETX><cccc>`

- Variable length record with one (1) to four (4) characters to the left of decimal character in first data field
- Fixed at one (1) character to the right of decimal character in first data field
- Variable length record with one (1) to four (4) characters in second data field
- Level 1 temperature data fields separated by ASCII colon (:) character
- Five (5) character checksum appended after the '<ETX>' character set

MULTIPLE OUTPUT COMMANDS (CONTINUED)

**Command 29 Hex (41 Dec):** *Level 1 (product) at 0.01 inch resolution, and average temperature at 0.2 °F resolution (with checksum)*

**Data format:** <STX><dddd.dd:dddd.d><ETX><cccc>

- Variable length record with one (1) to four (4) characters to the left of decimal character in first data field
- Fixed at two (2) characters to the right of decimal character in first data field
- Variable length record with one (1) to four (4) characters to the left of decimal character in second data field
- Fixed at one (1) character to the right of decimal character in second data field.
- Level 1, temperature data fields separated by ASCII colon (:) character.
- Five (5) character checksum appended after the '<ETX>' character set

**Command 2A Hex (42 Dec):** *Level 1 (product) at 0.001 inch resolution, and average temperature at 0.02 °F resolution (with checksum)*

**Data format:** <STX><dddd.dd:dddd.dd><ETX><cccc>

- Variable length record with one (1) to four (4) characters to the left of decimal character in first data field
- Fixed at three (3) characters to the right of decimal character in first data field
- Variable length record with one (1) to four (4) characters to the left of decimal character in second data field
- Fixed at two (2) characters to the right of decimal character in second data field
- Level 1, temperature data fields separated by ASCII colon (:) character
- Five (5) character checksum appended after the '<ETX>' character set

**Command 2B Hex (43 Dec):**  
*Level 1 (product), level 2 (interface) at 0.1 inch resolution, and average temperature at 1.0 °F resolution (with checksum)*

**Data format:** <STX><dddd.d:dddd.d:dddd><ETX><cccc>

- Variable length record with one (1) to four (4) characters to the left of decimal character in first data field
- Fixed at one (1) character to the right of decimal character in first data field
- Variable length record with one (1) to four (4) characters to the left of decimal character in second data field
- Fixed at one (1) character to the right of decimal character in second data field
- Variable length record with one (1) to four (4) characters in third data field
- Level 1, level 2, temperature data fields separated by ASCII colon (:) character
- Five (5) character checksum appended after the '<ETX>' character set

**Command 2C Hex (44 Dec):**  
*Level 1 (product), level 2 (interface) at 0.01 inch resolution, and average temperature at 0.2 °F resolution (with checksum)*

**Data format:** <STX><dddd.dd:dddd.dd:dddd.d><ETX><cccc>

- Variable length record with one (1) to four (4) characters to the left of

decimal character in first data field

- Fixed at two (2) characters to the right of decimal character in first data field
- Variable length record with one (1) to four (4) characters to the left of decimal character in second data field
- Fixed at two (2) characters to the right of decimal character in second data field
- Variable length record with one (1) to four (4) characters to the left of decimal character in third data field.
- Fixed at one (1) character to the right of decimal character in third data field
- Level 1, level 2, temperature data fields separated by ASCII colon (:) character
- Five (5) character checksum appended after the '<ETX>' character set

**Command 2D Hex (45 Dec):** *Level 1 (product), level 2 (interface) at 0.001 inch resolution, and average temperature at 0.02 °F resolution (with checksum)*

**Data format:** <STX><dddd.dd:dddd.dd:dddd.dd><ETX><cccc>

- Variable length record with one (1) to four (4) characters to the left of decimal character in first data field.
- Fixed at three (3) characters to the right of decimal character in first data field.
- Variable length record with one (1) to four (4) characters to the left of decimal character in second data field.
- Fixed at three (3) characters to the right of decimal character in second data field.
- Variable length record with one (1) to four (4) characters to the left of decimal character in third data field.
- Fixed at two (2) characters to the right of the decimal character in third data field.
- Level 1, level 2, temperature data fields separated by ASCII colon (:) character.
- Five (5) character checksum appended after the '<ETX>' character set

**Command 2E Hex - Command 30 Hex - Not Defined**

**Command 31 Hex - Command 40 Hex - Reserved for factory use**

HIGH-LEVEL MEMORY READ COMMANDS

**Command 4B Hex (75 Dec):** *Read 'number of floats and number of DTs' control variables*

**Data format:** <STX><d:d><ETX><cccc>

- Fixed length record with one (1) character in each field.
- The first data field is the number of floats, second data field is the number of DTs
- Five (5) character checksum appended after the '<ETX>' character set

**Command 4C Hex (76 Dec):** *Read 'gradient' control variable*  
**Data format:** <STX><d.ddddd><ETX><cccc>

- Fixed length record with seven (7) characters (including decimal point).
- Five (5) character checksum appended after the '<ETX>' character set

**Command 4D Hex (77 Dec):** *Read float zero position data (float #1 and #2)*

**Data format:** <STX><dddd.dd:dddd.d><ETX><cccc>  
*(Continued on next page)*

## HIGH-LEVEL MEMORY READ COMMANDS (CONTINUED)

### Command 4D Hex (77 Dec): continued

- Variable length record with one (1) to four (4) characters to the left of decimal character in first data field. The data may include an ASCII (-) negative sign character (2D Hex) in the first character position
- Fixed at three (3) characters to the right of decimal character in first data field
- Variable length record with one (1) to four (4) characters to the left of decimal character in second data field. The data may include an ASCII(-) negative sign character (2D Hex) in the first character position
- Fixed at three (3) characters to the right of decimal character in second data field
- Float #1, float #2 data fields separated by ASCII colon (:) character
- Five (5) character checksum appended after the '<ETX>' character set

### Command 4E Hex (78 Dec):

*Read DT position data (DTs 1 - 5)*

#### Data format:

<STX><ddd.d:ddd.d:ddd.d:ddd.d:ddd.d><ETX><cccc>

- Variable length record with one (1) to four (4) characters to the left of decimal character in each data field
- Fixed at one (1) character to the right of decimal character in each data field
- Variable number of data fields (up to 5) separated by ASCII colon (:) characters. The number of data fields is based on the 'number of DTs' control variable. (see command 4B Hex)
- The first data field is always DT #1, second field is always DT #2,...etc.
- Five (5) character checksum appended after the '<ETX>' character set

#### Note:

DT position data is referenced from the mounting flange of the transmitter housing. DT #1 is the DT closest to the tip of the transmitter.

### Command 4F Hex (79 Dec):

*Read factory serial number data and software version number*

#### Data format:

<STX><dddd...dddd:Vd.ddd><ETX><cccc>

- Fixed length record of 50 characters to the left of the colon character and 6 characters to the right of the colon character (57 total)
- Five character checksum appended after the '<ETX>' character set

### Command 50 Hex (80 Dec):

*Read firmware control code #1*

#### Data format:

<STX><d:d:d:d:d><ETX><cccc>

- Fixed length record with one (1) character in each data field
- First data field is the control variable for the data error detection (DED) mode
- The second data field is the control variable for the communication time-out timer (CTT)
- The third data field is the control variable for temperature data units
- The fourth data field is the control variable for linearization enable/disable
- The fifth data field is the control variable for innage/ullage level output
- The sixth data field is reserved for future use; the output value for this

field is ASCII '0'

- See write command (5A Hex) for field value assignments
- Five (5) character checksum appended after the '<ETX>' character set

**Command 51 Hex (81 Dec):** *Read hardware control code #1*  
**Data format:** <STX><dddd><ETX><cccc>

- Fixed length record with six (6) characters
- The hardware control code controls various functions in the DDA electronic hardware
- The hardware control code must match the hardware control code stamped on the transmitter label; the control code on the label is preceded by 'CC' (for example, CC001122)
- Five (5) character checksum appended after the '<ETX>' character set
- For additional information about the hardware control code, (see section 8, Quick Start-up Guide Modbus and DDA)

**Command 52 Hex (82 Dec):** *Not defined*

**Command 53 Hex (83 Dec):** *Reserved for factory use*

**Command 54 Hex (84 Dec):** *Not defined*

## HIGH-LEVEL MEMORY WRITE COMMANDS

**Command 55 Hex (85 Dec):** *Write 'number of floats and number of DTs' control variables*

### Host Issued Command (Part 1)

**Data format:** <addr><commands>

- '<addr>' is the DDA transmitter address
- '<command>' is DDA command 55
- After the address and command byte have been transmitted by the host, the respective DDA transmitter will 'wake up' and retransmit (echo) the local DDA address and received command. The DDA transmitter will remain active, waiting for the second part of the memory write command to be issued by the host. If the second part of the memory write command is not received within 1.0 seconds (see note below), or the command is not received in the proper format, the DDA transmitter will cancel the current command sequence and go back to sleep mode.

#### Note:

The time-out timer function can be enabled or disabled.

### Host Issued Command (Part 2)

**Data format:** <SOH><d:d><EOT>

- Fixed length record with two (2) data fields
- '<SOH>' is ASCII 01 Hex
- The first data field contains the 'number of floats' value to be written to the 'number of floats' control variable. This variable is limited to a value of 1 or 2 (ASCII)
- The second data field contains the 'number of DTs' value to be written to the 'number of DTs' control variable. This variable is limited to a value between 0 and 5 (ASCII)
- ASCII colon (:) is the 'number of floats/number of DTs' field separator.
- '<EOT>' is ASCII 04 Hex

### DDA Transmitter Response (verification sequence)

**Data format:** <STX><d:d><ETX><cccc>

HIGH-LEVEL MEMORY WRITE COMMANDS (CONTINUED)

- Fixed length record with two (2) data fields
- '<STX>' is ASCII 02 Hex
- The first data field contains the 'number of floats' value to be written to the 'number of floats' control variable. This variable is limited to a value of 1 or 2 (ASCII)
- The second data field contains the 'number of DTs' value to be written to the 'number of DTs' control variable. This variable is limited to a value between 0 and 5 (ASCII)
- ASCII colon (:) is the 'number of floats/number of DTs' field separator
- '<ETX>' is ASCII 03 Hex
- '<ccccc>' is a five (5) character checksum appended after the '<ETX>' character set

Host Issued Command (Part 3)

Data format: <ENQ>

- '<ENQ>' is ASCII 05 Hex. This character set is sent by the host to initiate the EEPROM write cycle. After the EEPROM memory locations have been successfully written to, the DDA transmitter will respond back to the host with a 'ACK' character set signifying the memory write cycle was successful, or with a 'NAK' character signifying the memory write cycle was unsuccessful. See DDA transmitter response below.
- EEPROM write time is 10 milliseconds per byte. The 'ACK/NAK' response will not be transmitted by the DDA transmitter until the memory bytes have been written and verified or a memory write error has caused the DDA transmitter to time-out.

**Note:**  
EEPROM write time is 10 milliseconds per byte. The ACK/NAK response will not be transmitted by the DDA transmitter until the memory bytes have been written and verified or a memory write error has caused the DDA transmitter to time-out.

DDA Transmitter Response:

Data format: <ACK>

- '<ACK>' is ASCII 06 Hex. This character set is sent by the DDA transmitter to confirm to the host that the EEPROM memory write cycle was completed successfully.

Data format: <NAK><Exxx><ETX><ccccc>

- '<NAK>' is ASCII 15 Hex. This character set is sent by the DDA transmitter to confirm to the host that the EEPROM memory write cycle was not completed successfully.
- '<Exxx>' is an error code defining the memory write error that occurred during the EEPROM write cycle. 'E' is ASCII 45 Hex and 'xxx' is the numeric ASCII error code ranging from 000 to 999. For additional information about DDA error codes, (see section X.X).
- '<ETX>' is ASCII 03 Hex
- '<ccccc>' is a five character checksum appended after the '<ETX>' character set
- Value can range from 00000 to 65535.

All high level memory write commands adhere to the communication sequence as described above, and consist of the following six components:

1. Host issued command (Part 1): <address><command>
2. DDA transmitter response: <address><command> echo
3. Host issued command (Part 2):  
data to be written (including necessary control characters)
4. DDA transmitter response: verification sequence
5. Host issued command (Part 3): <ENQ>
6. DDA transmitter response: <ACK> or <NAK>

Descriptions for other high level memory write commands will include only the Data format for Part 2 of each host issued command.

Command 56 Hex (86 Dec): Write 'gradient' control variable  
Data format: <SOH><d.ddd><EOT>

- Fixed length record with one data field
- '<SOH>' is ASCII 01 Hex
- The fixed length data field contains the 'gradient' value to be written to the 'gradient' control variable. This variable is limited to a value between 7.00000 and 9.99999 (ASCII)
- '<EOT>' is ASCII 04 Hex

Command 57 Hex (87 Dec): Write float zero position data (float #1 or #2)

Data format: <SOH><c.ddd.d><EOT>

- Variable length record with two (2) data fields
- The first data field contains one character that controls which zero position memory location is written to (i.e., float #1 or float #2). This control character is limited to a value of 1 or 2 (ASCII)
- The second data field contains the 'zero position' data value to be written to the 'zero position' memory location. This is a variable length data field with one (1) to four (4) characters to the left of the decimal character and fixed at three (3) characters to the right of the decimal character. The data may include the ASCII (-) negative sign character (2D Hex) in the first position. The zero position data is limited to a value between -999.999 and 9999.999 (ASCII)
- '<EOT>' is ASCII 04 Hex

**Note:**  
Zero position is referenced from the mounting flange of the transmitter housing.

Command 58 Hex (88 Dec): Write float zero position data (float #1 or #2) using DDA calibrate mode.

Data format: <SOH><c.ddd.d><EOT>

- Variable length record with two (2) data fields
- The first data field contains one character that controls which zero position memory location is written to (i.e., float #1 or float #2). This control character is limited to a value of 1 or 2 (ASCII)
- The second data field contains the 'current float position' data value to be used to calculate the 'zero position' value that is to be written to the 'zero position' memory location. This is a variable length data field with one (1) to four (4) characters to the left of the decimal character and fixed at three (3) characters to the right of the decimal character. The data may include the ASCII (-) negative sign character (2D Hex) in the first position. The 'current float position' data is limited to a value between -999.999 and 9999.999 (ASCII)
- '<EOT>' is ASCII 04 Hex

## HIGH-LEVEL MEMORY WRITE COMMANDS (CONTINUED)

**Command 59 Hex (89 Dec):** Write DT position data (DT1-5).

**Data format:** <SOH><c:ddd.d><EOT>

- Variable length record with two (2) data fields
- The first data field contains one (1) character that controls which 'DT position' memory location is written to (i.e. DT position #1, 2, 3, 4 or 5)
- This control character is limited to a value between 1 and 5 (ASCII)
- The second data field contains the 'DT position' data value to be written to the respective 'DT position' memory location. This is a variable length data field with one (1) to four (4) characters to the left of the decimal character and fixed at one (1) character to the right of the decimal character. The DT position data is limited to a value between 0.0 and 9999.9 (ASCII)
- '<EOT>' is ASCII 04 Hex

**Command 5A Hex (90 Dec):** Write firmware control code #1

**Data format:** <SOH><d:d:d:d:d><EOT>

- Fixed length record with one character in each data field
- '<SOH>' is ASCII 01 Hex
- The first data field is the control variable for the data error detection (DED) function. This variable can have a value of 0, 1, or 2. A value of 0 enables the DED function, using a 16-bit checksum calculation. A value of 1 enables the DED function, using a 16-bit CRC calculation. A value of 2 disables the DED function
- The second field is the control variable for the communication time-out timer (CTT) function. This variable can have a value of 0 or 1. A value of 0 enables the CTT function, and a value of 1 disables the CTT function
- The third data field is the control variable for temperature data units. This variable can have a value of 0 or 1. A value of 0 enables Fahrenheit temperature units. A value of 1 enables Celsius temperature units
- The fourth data field is the control variable for linearization control. This variable can have a value of 0 or 1. A value of 0 disables linearization of the level data. A value of 1 enables linearization
- The fifth data field is the control variable for innage/ullage level output. This variable can have a value of 0,1 or 2. A value of 0 enables normal innage level output. A value of 1 enables ullage level output and a value of 2 enables ullage level output with reversed DT submersion processing. Mode 2 is used for inverted transmitter applications where the transmitter is installed from the bottom of the tank
- The sixth data field is reserved for future use. The data value for this field must be '0' (ASCII 30 Hex)
- '<EOT>' is ASCII 04 Hex

**Command 5B Hex (91 Dec):** Write hardware control code #1

**Data format:** <SOH><dddddd><EOT>

- Fixed length record with six (6) characters
- '<SOH>' is ASCII 01 Hex
- The hardware control code controls various functions in the DDA electronic hardware
- The hardware control code must match the hardware control code stamped on the transmitter label. The control code on the label is preceded by 'CC' (i.e. CC001122)
- '<EOT>' is ASCII 04 Hex

**Command 5C Hex (92 Dec):** Not Defined

**Command 5D Hex (93 Dec):** Reserved for factory use

**Command 5F Hex - 7F Hex - Reserved for future use**

## DIAGNOSTIC/SPECIAL COMMAND SET

<b>enum alarmStatusBits</b>	
<b>INTERFACE_ALARM_HIGH</b>	= 0x0001
<b>INTERFACE_ALARM_LOW</b>	= 0x0002
<b>PRODUCT_ALARM_HIGH</b>	= 0x0004
<b>PRODUCT_ALARM_LOW</b>	= 0x0008
<b>ROOF_ALARM_HIGH</b>	= 0x0010
<b>ROOF_ALARM_LOW</b>	= 0x0020
<b>AVG_TEMP_ALARM_HIGH</b>	= 0x0040
<b>AVG_TEMP_ALARM_LOW</b>	= 0x0080
<b>MAGNET_IS_MISSING</b>	= 0x0100
<b>DIG_TEMP0_ERROR</b>	= 0x0200
<b>DIG_TEMP1_ERROR</b>	= 0x0400
<b>DIG_TEMP2_ERROR</b>	= 0x0800
<b>DIG_TEMP3_ERROR</b>	= 0x1000
<b>DIG_TEMP7_ERROR</b>	= 0x2000
<b>DIG_AVG_TEMP_ERROR</b>	= 0x4000
<b>DELIVERY_IN_PROGRESS</b>	= 0x8000
<b>TRIGGER_LEVEL_ERROR</b>	= 0x10000
<b>EEPROM_ERROR</b>	= 0x20000

## DDA ERROR CODES

All error codes are preceded by a capital letter 'E' ASCII (45 hex) and are in the form of 'Exxx' where 'xxx' can be any number from '000' to '999'. Error codes can be embedded in any data field within a transmitted record. Certain DDA commands can generate multiple error codes. Refer to the following examples:

**Command 0A Hex:**

<STX><Exxx><ETX><cccc>

**Command 2D Hex:**

<STX><Exxx:Exxx:ddd.dd><ETX><cccc>

**Command 1E Hex:**

<STX><E203:dddd.dd:dddd.dd:E207:ddd.dd><ETX><cccc>

**E102:** Missing Float(s) (Level 1 or Level 2)

The number of floats measured by the hardware is less than the 'number of floats' control variable.

**E201:** No DTs Programmed

A request for temperature data has been made with the 'number of DTs' control variable set to equal zero (0) or all programmed DTs are set inactive (for example, DT position data is set equal to zero (0.000)).

**E212:** DT Communication Error

The indicated DT is not active (for example, DT position data is set equal to zero (0) or is not responding).

**Model MG Digital setup software installation, setup and calibration**

Adjustments to the calibration and set up parameters of the transmitter can be performed using the M-Series Digital Setup Software package. The software can be run from any PC using a RS-485 to RS-232 converter (see Table 10 MTS part number references). In the 'MTS Digital Gauge Configuration - DDA -COM' window, you will see one tab labeled 'Data From Device' (see Figure 28). You will use this tab and its button selections to calibrate the transmitter and change setup parameters.

**Note:**  
 You must use a RS-485 converter with 'Send Data Control' when using the M-Series Digital Setup software to ensure proper operation.  
*Example:* B & B Electronics 485BAT3 (815-433-5100 www.bb-elec.com).

<b>Level Plus M-Series PC Digital Setup Software (DDA) CD</b>	<b>RS-485 to RS-232 converter</b>
Order number: 625053	Order number: 380075

**Table 10.** MTS part number references

**DATA FROM DEVICE TAB**

Perform the following steps to install the transmitter setup software to establish communications with the transmitter:

1. Install Setup Software from the CD that came with your transmitter or go to [www.mtssensors.com](http://www.mtssensors.com) to download the latest version.
2. Connect transmitter to the RS-485 to RS-232 converter and attach the converter to your PC. Some PC's will require an additional Serial to USB converter.
3. Open the Software program.
4. Select **COM Port**. If you do not know which COM port to select, right click **My Computer** and select **Properties -> Hardware Tab -> Device Manager -> Ports (COM & LPT)** to view the list.
5. Click the 'Data From Device' tab, click the **Device:** pull-down and select the 'transmitter address', the factory default for DDA is **192** (see Figure 28).

Parameter settings and calibration is performed from within the Data From Device tab window (see Figure 28).

**DATA FROM DEVICE tab options:**

- Calibrate
- Change Address
- COM port
- Adjust settings
- Backup and restore device settings

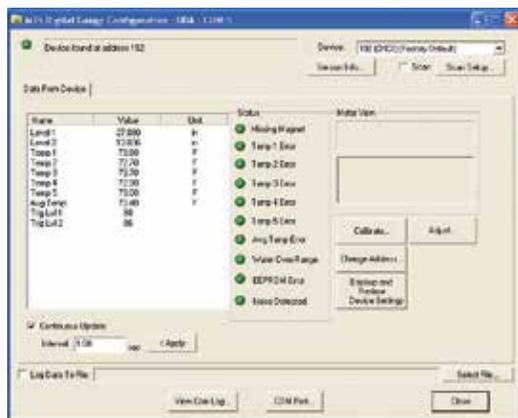

**Figure 28.** Data from device tab

**CALIBRATION**

When you click the '**Calibrate**' button in the 'Data From Device' tab window, the '*Calibrate DDA Device*' window opens. There are two calibration 'Float Methods' to choose from, '**Enter Float Positions (Calibrate)**' and '**Enter Float Zero Positions**'. Click the '**Offset Method:**' drop down menu to select a calibration method. Type a *value* in the active field, then click the '**Send**' button. A confirmation window displays when the send is successful.



**Figure 29.** Calibrate DDA Device window - Offset Method

When you choose '**Enter Float Zero Positions**' from the '*Offset Method:*' drop down menu, you can adjust the offset where the transmitters zero point is located. This adjustment will significantly shorten the span of the transmitter or counter inactive zones. Adjust the value accordingly and click '**Send**'. A confirmation window displays when the send is successful.



**Figure 30.** Calibrate DDA Device - Offset Method

**DDA User Interface**

## CHANGE ADDRESS

To change the transmitter address, click the **'Change Address'** button in the *'Data From Device'* tab window. In the *'Change Address'* window, type the **'New Address'** in the active field and click **'Change'**. A popup window confirms the change is successful.

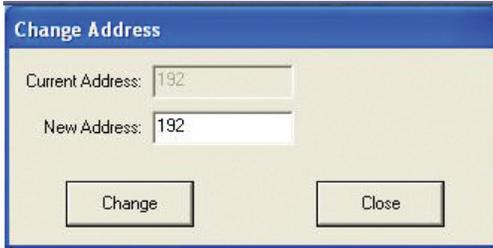

Figure 31. Change Address window - New Address entry

## BACKUP AND RESTORE DEVICE SETTINGS

If your electronics requires a replacement or if your current settings need to be refreshed, it is recommended that you create a backup or restoration file. To create a backup, click the **'Backup/Restore'** button in the *'Data From Device'* tab window. In the *'Backup and Restore Device Settings'* window, click the **'Get Data From Sensor'** button and **'Save Settings to File'** button. When prompted, save the file to a designated place where you can find it.

To upload a file, click the **'Read Settings from File'** button and select your backup file. Click **'Write Data to Sensor'**. A popup window confirms the upload is successful.

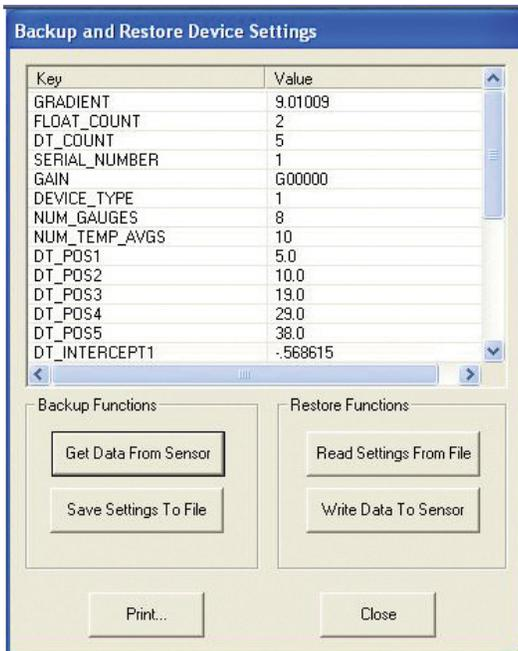

Figure 32. Backup and Restore Device Settings window

### Adjust settings

To adjust settings, click the **'Adjust'** button located in the *'Data From Device'* tab window (see Figure 28). The *'Adjust DDA Gain'* window displays different parameter settings. All transmitters will have the

ability to adjust the *'Gain, SARA Blanking and Magnet blanking'* from this menu. These parameters are password protected, changes will require assistance from *MTS Technical Support*.

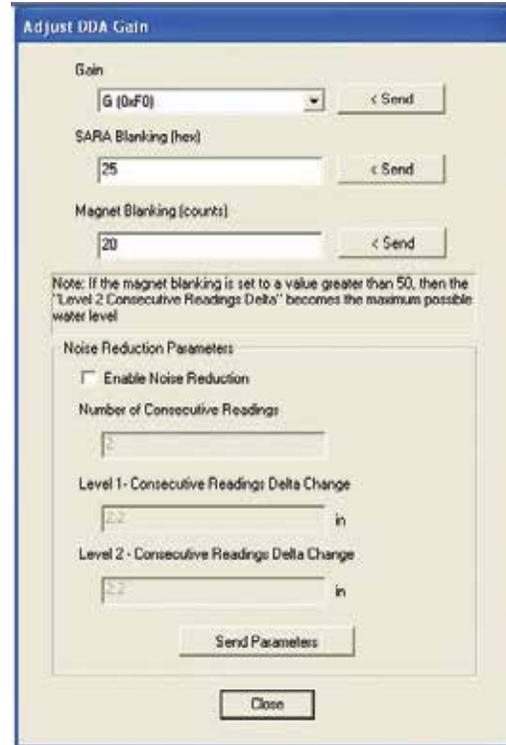

Figure 33. Adjust DDA Gain window

## COM PORT

To select the Setup Software communication port, click the **'COM Port'** button in the *'Data From Device'* tab window. Select the appropriate communication port and click **'OK'**.

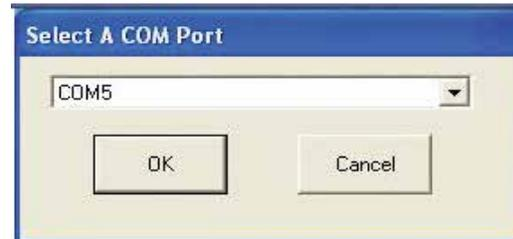

Figure 34. Select a COM Port window

## CONTINUOUS UPDATE

To view realtime data using the Setup Software interface, select the **'Continuous Update'** box. The Interval may be changed to slow down updates but is not necessary.

## DATA LOGGING

To download a transmitter data log, Click **'Select File'** in the *'Data From Device'* tab window. Select an Excel file and check the **'Log Data to File'** box to save your data.

## Agency approvals

### FM/CSA

#### FM/CSA SPECIFIC MODEL MG NUMBER REQUIRED AS SHOWN ON PAGE 8.

Model	Approval Type	Classification	Standard
<b>MGAM</b> <b>MGAD</b>	Explosion Proof	Class I, Division 1, Groups B, C, D Class II, Division 1, Groups E, F, G Division 1, Type 4X Ta = 71° C	FM 3600:2011 FM 3615:2006 CSA C22.2 No. 0-M91 (R2001) CSA C22.2 No. 30-M1986
	Intrinsically Safe	Class I, Division 1, Groups A, B, C, D Class II, Division 1, Groups E, F, G Division 1, Type 4X Ta = 71° C	FM 3610:2010 CSA C22.2 No. 157-92
<b>MGAF</b>	Explosion Proof	Class I, Division 1, Groups B, C, D Class II, Division 1, Groups E, F, G Division 1, Type 4X Ta = 71° C	FM 3600:2011 FM 3615:2006 CSA C22.2 No. 0-M91 (R2001) CSA C22.2 No. 30-M1986

### ATEX

#### ATEX SPECIFIC MODEL MG NUMBER REQUIRED AS SHOWN ON PAGE 9.

Model	Approval Type	Classification	Standard
<b>MGEM</b> <b>MGED</b>	Flame Proof	FM13ATEX0050X ⊕ II 1/2 G Ex d IIB T4 Ga/Gb Ta = -20° C to 40° C	EN 60079-0:2012 EN 60079-1:2007 EN 60079-26:2007
	Intrinsically Safe	PTB 04 ATEX 2028X ⊕ II 1/2 G bzw. II 2 G EEx ia IIB T4 bzw. EEx ia IIA T4 Ta = -20° C to 80° C	EN 50014:1997+A1+A2 EN 50020:2002 EN 50284:1999
<b>MGEF</b>	Flame Proof	FM13ATEX0050X ⊕ II 1/2 G Ex d IIB T4 Ga/Gb Ta = -20° C to 40° C	EN 60079-0:2012 EN 60079-1:2007 EN 60079-26:2007

### CCOE

#### CCOE USES ATEX SPECIFIC MODEL NUMBER AS SHOWN ON PAGE 9.

Model	Approval Type	Classification	Standard
<b>MGP</b>	Flame Proof	P336577/1 Ex d IIB T4 Ga/Gb Ta = -20° C to 40° C	EN 60079-0: 2012 EN 60079-1:2007 EN 60079-26:2007

### KC

#### KC USES IEC EX SPECIFIC MODEL NUMBER AS SHOWN ON PAGE 9, CONSULT 550720 (KOR) FOR DETAILS

Model	Approval Type	Classification	Standard
<b>MGK</b>	Flame Proof	14-KB4BO-0300X Ex d IIB T4 Ga/Gb Ta = -20° C to 40° C	Announcement No. 2013-54 of Ministry of Employment and Labor

## Agency approvals (Cont.)

### IECEX

#### IECEX SPECIFIC MODEL MG NUMBER REQUIRED AS SHOWN ON PAGE 9.

Model	Approval Type	Classification	Standard
<b>MGHM</b> <b>MGHD</b> <b>MGHF</b>	Flame Proof	IECEX FMG 13.0019X Ex d IIB T4 Ga/Gb Ta = -20° C to 40° C	IEC 60079-0:2011 IEC 60079-1:2007 IEC 60079-26:2006

### INMETRO

#### INMETRO USES ATEX SPECIFIC MODEL NUMBER AS SHOWN ON PAGE 9, CONSULT 550720 (PT) FOR DETAILS

Model	Approval Type	Classification	Standard
<b>MGB</b>	Flame Proof	TÜV 14.0935 Ex d IIB T4 Ga/Gb IP66 Ta = -20° C to 40° C	ABNT NBR IEC 60079-0:2008 ABNT NBR IEC 60079-1:2009 e ABNT NBR IEC 60079-26:2008 Portaria INMETRO no 179 de 18/05/2010

### NEPSI

#### NEPSI USES FM/CSA SPECIFIC MODEL MG NUMBER REQUIRED AS SHOWN ON PAGE 8.

Model	Approval Type	Classification	Standard
<b>MGAM</b> <b>MGAD</b>	Flame Proof	Ex d IIB T4 Gb Ta = -20° C to 60° C	GB3836.1-2010 GB3836.2-2010
	Intrinsically Safe	Ex ia IIC T4 Ta = -20° C to 60° C	GB3836.1-2000 GB3836.4-2000
<b>MGAF</b>	Flame Proof	Ex d IIB T4 Gb Ta = -20° C to 60° C	GB3836.1-2010 GB3836.2-2010

### ABS

MTS Sensors has Type Approval on the MG level transmitter. Please see attached certificate or listing on the ABS website for more details.

Hazardous area installation

FM/CSA FOR MODBUS AND DDA

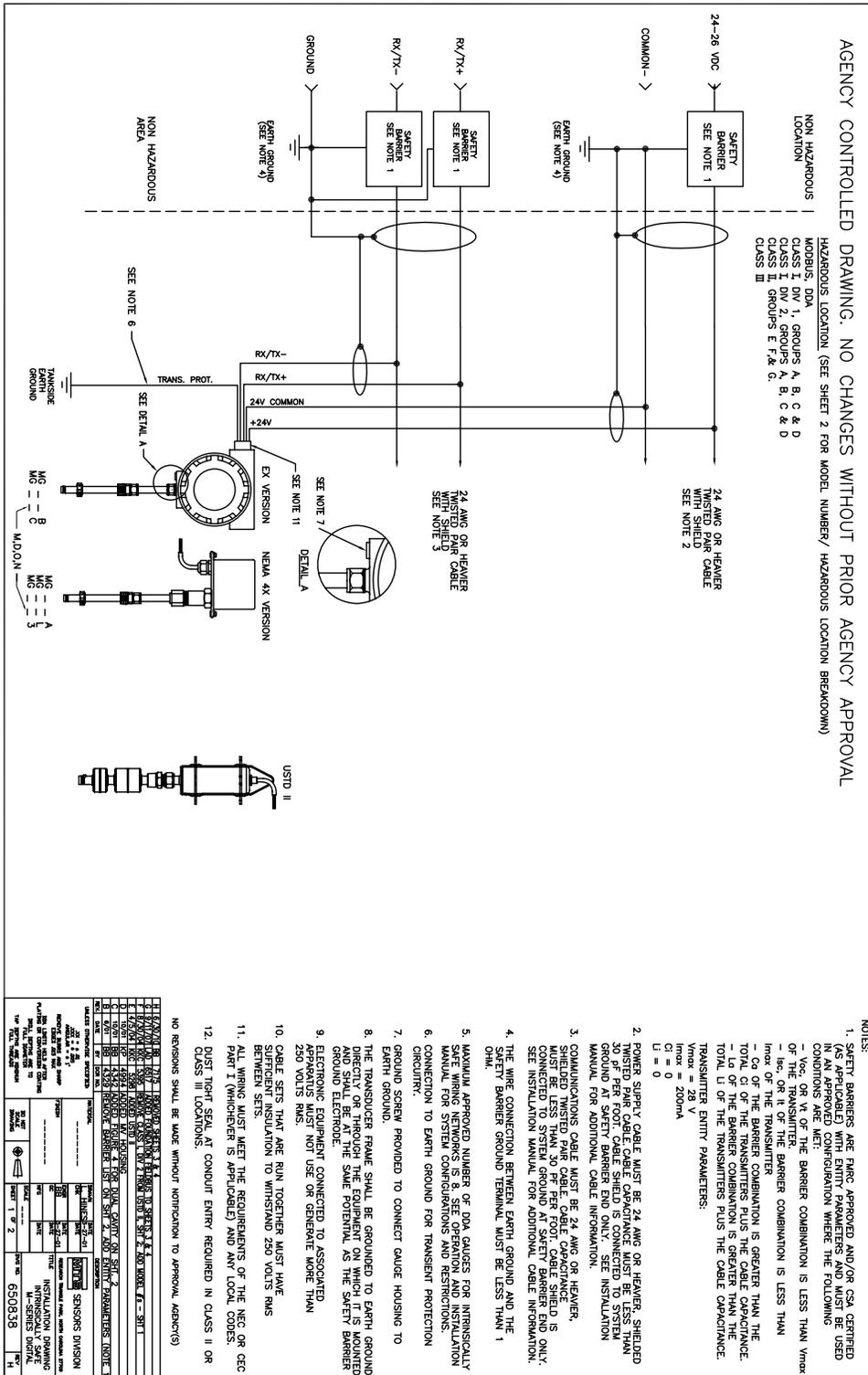

Figure 35. Modbus and DDA installation drawing

**INSTALLATION DRAWING NOTES (FIGURE 35)**

Model number	Approval agency		Approval type		Approval classification	Ground connection <i>(Figure references)</i>
	FM	CSA	EX	IS		
<b>MGA_B</b>	X	X	X		CL. I, DIV. 1, GR. B, C, D CL. II, DIV. 1, GR. E,F,G CLASS III	Figure 36
	X	X		X	CL. I, DIV. 1, GR. A, B, C, D CL. II, DIV. 1, GR. E,F,G CLASS III	
<b>MGA_C</b>	X	X	X		CL. I, DIV. 1, GR. B, C, D CL. II, DIV. 1, GR. E,F,G CLASS III	Figure 37
	X	X		X	CL. I, DIV. 1, GR. A, B, C, D CL. II, DIV. 1, GR. E,F,G CLASS III	
<b>MGA_L</b>	X	X		X	CL. I, DIV. 1, GR. A, B, C, D	Figure 38
<b>MGA_3</b>	X	X		X	CL. I, DIV. 1, GR. A, B, C, D CL. II, DIV. 1, GR. E,F,G CLASS III	Figure 39

**Table 11.** Product Model / Hazardous location breakdown, Modbus DDA

**WIRING CONNECTIONS**

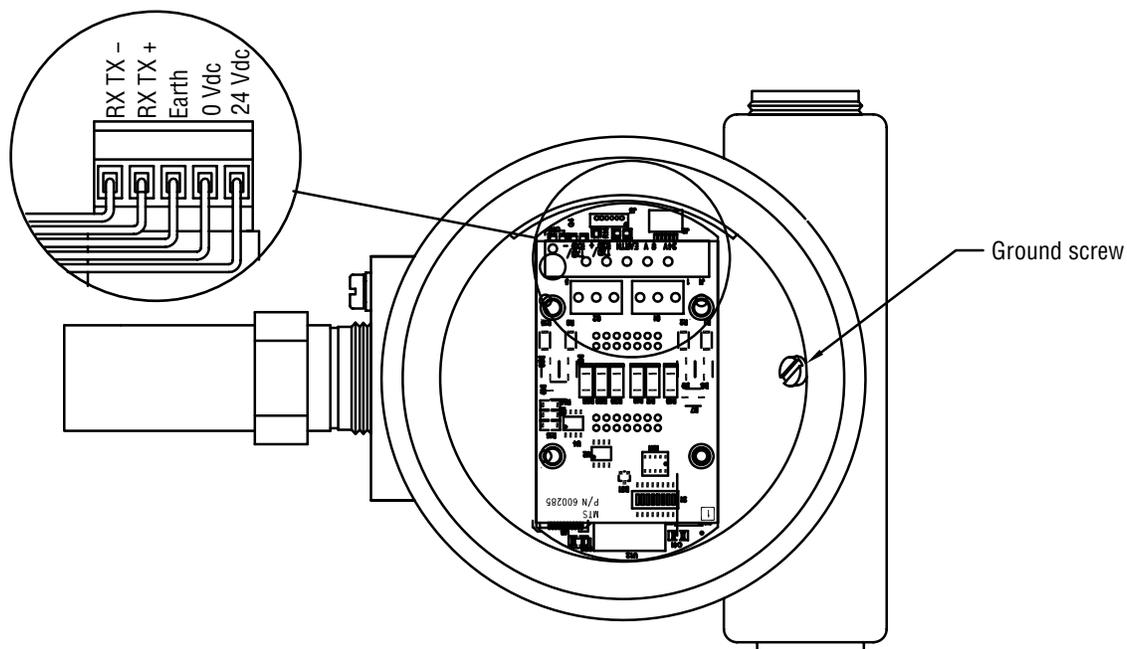

**Figure 36.** Single cavity housing

**Note:**

Ground screw provided in housing to connect gauge housing to earth ground.

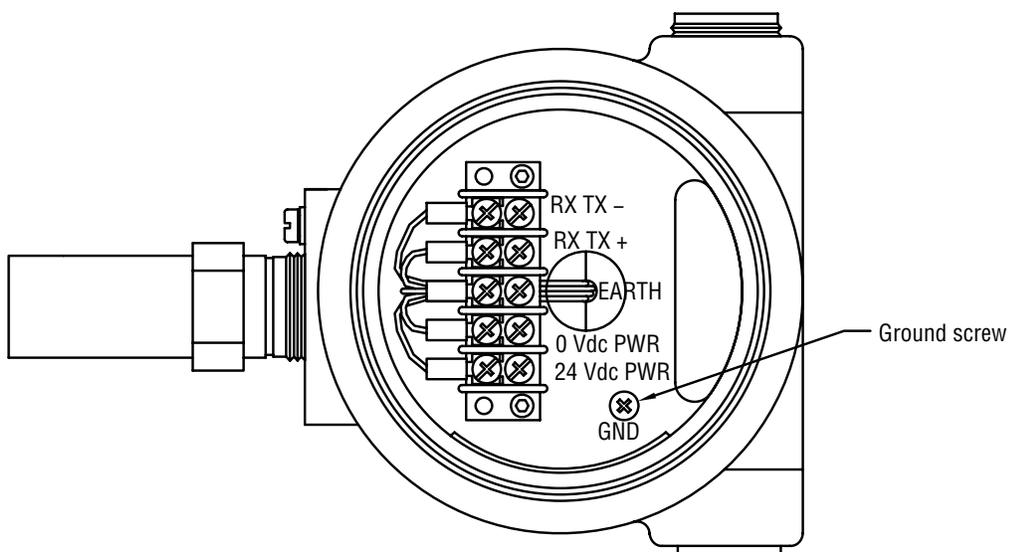

**Figure 37.** Dual cavity housing

**WIRING CONNECTIONS (CONTINUED)**

**Note:**  
 The transient protection pin on the connector (pin 6) is designated as the enclosure earth ground and should be at the same potential as the zener barrier earth ground.

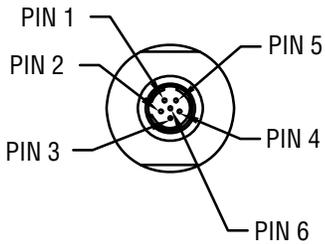

Wiring diagram (MG__L)	
Pin number	Signal
Pin 1	24 Vdc Power
Pin 2	0 Vdc Power
Pin 3	Earth ground
Pin 4	RX TX+
Pin 5	RX TX -
Pin 6	Transient protection

**Figure 38.** NEMA housing with connector

**Note:**  
 On customer installed cable version, customer to attach earth ground lead to connector as shown below and install transient protection lead (cable shield) with ground screw, lock washer, terminal cup, and bracket as shown above.

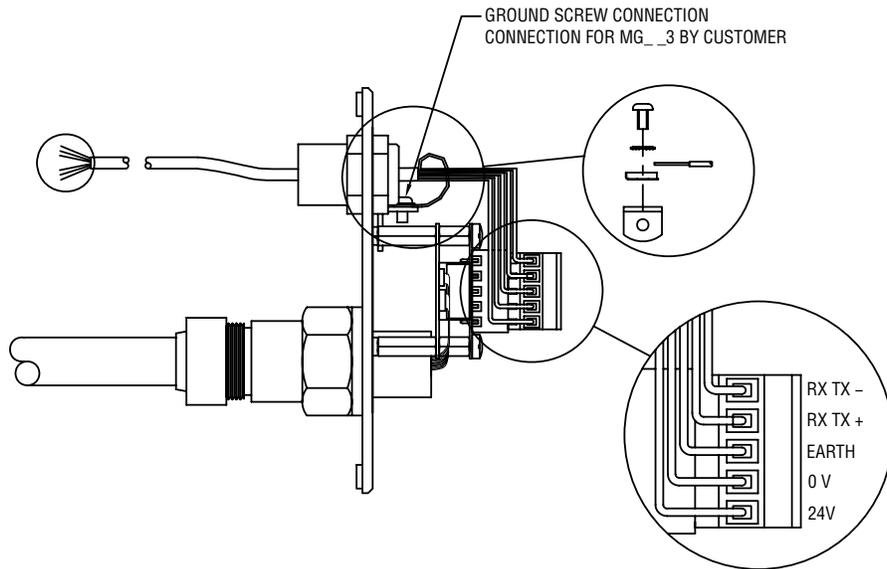

**Figure 39.** NEMA housing with terminal block





**Model MG Operation and Installation Manual**  
**Agency Information, ATEX, IECEx, and CCoE for Modbus and DDA**

**INSTALLATION DRAWING NOTES (CONTINUED)**

Model Number	Approval Agency				Approval Type		Approval classifications	Ground Connection <i>(Figure reference)</i>	
	Modbus/ DDA	PTB (ATEX)	FM (ATEX)	FM (IECEx)	PESO (CCoE)	Intrinsically Safe			Flame Proof
MGH_B			X				X	Ex d IIB T4 Ga/Gb	Figure 45
MGH_C			X				X	Ex d IIB T4 Ga/Gb	Figure 46
MGE_B		X					X	⊕ Ex II 1/2 G Ex d IIB T4 Ga/Gb	Figure 45
MGE_C		X					X	⊕ Ex II 1/2 G Ex d IIB T4 Ga/Gb	Figure 46
MGP_B					X		X	Ex d IIB T4 Ga/Gb	Figure 45
MGP_C					X		X	Ex d IIB T4 Ga/Gb	Figure 46
MGE_F	X					X		⊕ Ex II 1/2 G bzw. II 2 G EEx ia IIA T4	Figure 44
MGE_G	X					X		⊕ Ex II 1/2 G bzw. II 2 G EEx ia IIA T4	Figure 45
MGE_H	X					X		⊕ Ex II 1/2 G bzw. II 2 G EEx ia IIA T4	Figure 46
MGE_P	X					X		⊕ Ex II 1/2 G bzw. II 2 G EEx ia IIB T4	Figure 44
MGE_R	X					X		⊕ Ex II 1/2 G bzw. II 2 G EEx ia IIB T4	Figure 45
MGE_S	X					X		⊕ Ex II 1/2 G bzw. II 2 G EEx ia IIB T4	Figure 46
MGE_4	X					X		⊕ Ex II 1/2 G bzw. II 2 G EEx ia IIB T4	Figure 44
MGE_5	X					X		⊕ Ex II 1/2 G bzw. II 2 G EEx ia IIA T4	Figure 44

**Figure 43c** ATEX, IECEx, and CCoE for Modbus and DDA installation drawing (continued)

## WIRING AND CONNECTIONS

Wiring diagram (MGE\_F, MGE\_P)

Wire color	Signal
Red	24 Vdc Power
Black	0 Vdc Power
Blue	Earth ground
White	RX TX+
Green	RX TX -
Drain wire	Transient protection

**Note:**

On customer installed cable version, customer to attach earth ground lead to connector as shown below and install transient protection lead (cable shield) with ground screw, lock washer, and bracket as shown above.

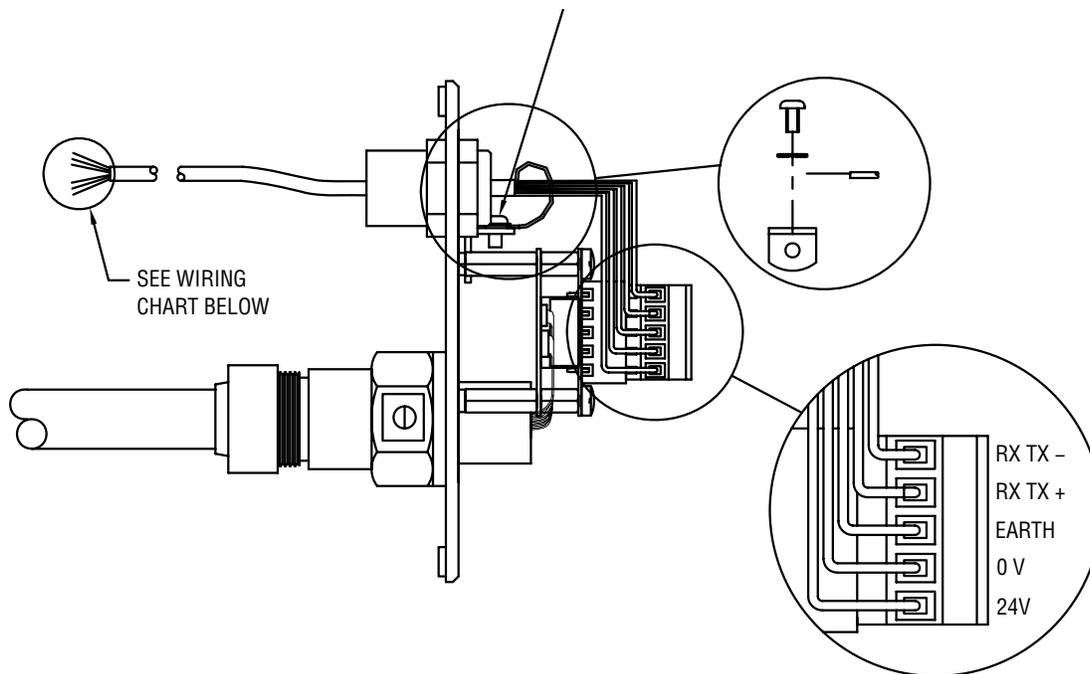
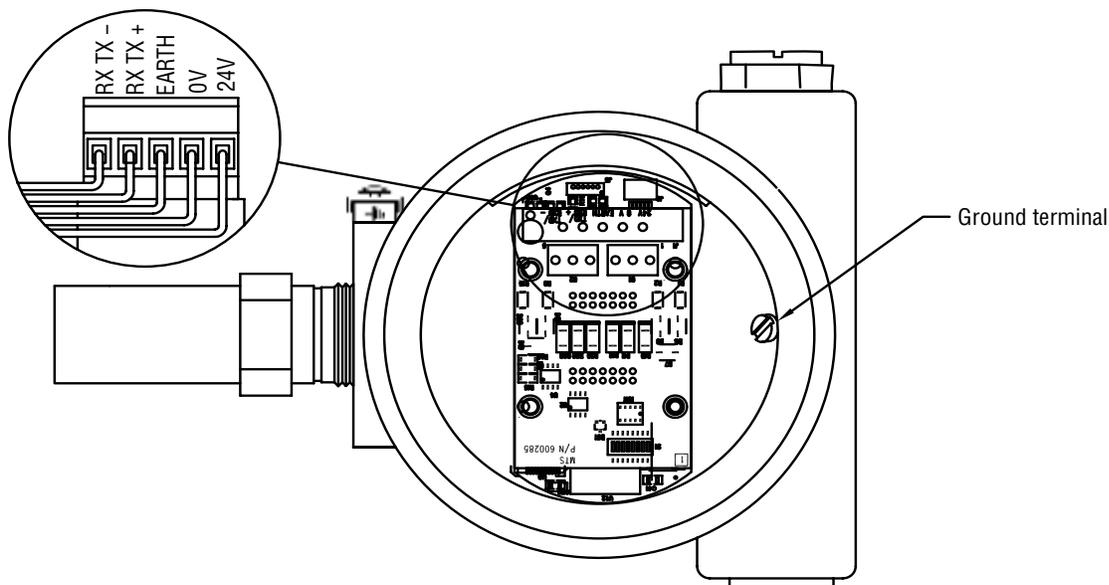

**Figure 44.** NEMA housing with terminal strip or integral cable

**Note:**

Ground terminal provided in housing to connect gauge housing to earth ground.

**WIRING AND CONNECTIONS (CONTINUED)**



**Figure 45.** Single cavity housing

**Note:**

Ground terminal provided in housing to connect gauge housing to earth ground.

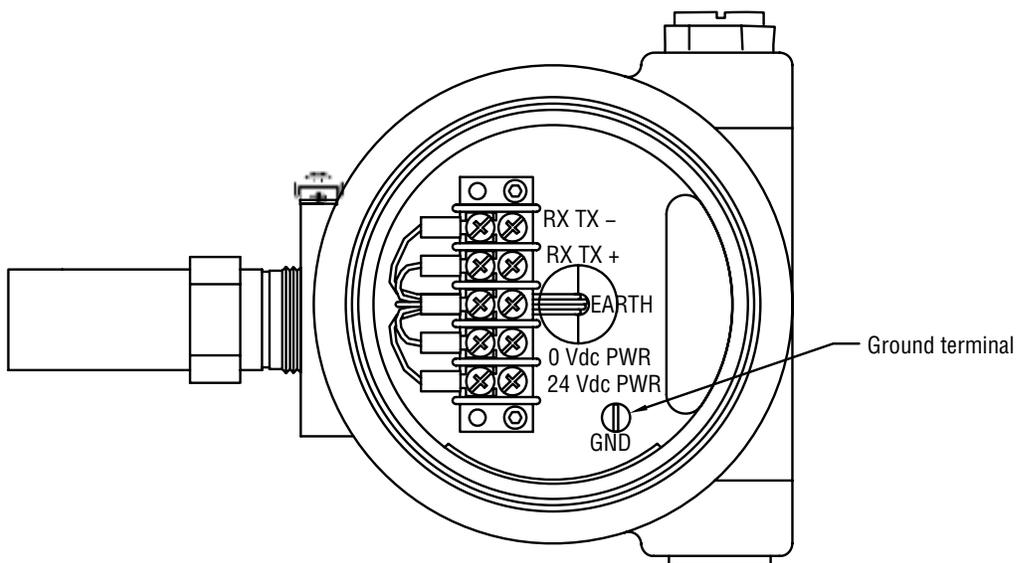

**Figure 46.** Dual cavity housing

### SPECIAL CONDITIONS FOR USE

- Model MG sensors may only be connected to certified intrinsically safe circuits (Ex ia or Ex ib).
- The electronics housing is to be installed in zone 1 (category 2G, EPL Gb). The sensor pipe/hose may be installed in zone 0 (category 1, EPL Ga) if not restricted below.
- Equipotential bonding shall be installed inside and outside the hazardous area along the cable for supply and data.
- Float usage:
  - Metallic floats may only be used if they have a weight offset (asymmetric weight distribution).
  - Metallic floats on non-metallic pipes may not be used.
  - Aluminum floats may not be used.
- Plastic floats may only be installed in hazardous areas which require apparatus of category 1G (for zone 0) with explosion group IIA. Plastic floats may not be used on non-metallic pipes.
- Sensors with flexible measuring hoses:
  - The hose has to be mechanically protected from external impacts which may affect its function as separation wall.
  - Avoid kinking or bending the flexible hose in less than 16 inch (406 mm) diameter.
- Consult MTS if dimensional information on flameproof joints are necessary.



**Model MG Operation and Installation Manual**  
**Agency Information, FM/CSA FOUNDATION™ fieldbus**

**INSTALLATION DRAWING NOTES**

Model number FOUNDATION™ fieldbus	Approval agencies		Approval types	Approval classifications	Ground connection (Figure references)
	FM	CSA	EX		
MGAFB MGASB	X	X	X	CL. I, DIV. 1, GR. B, C, D CL. II, DIV. 1, GR. E,F,G CLASS III	Figure 54
MG AFC MGASC	X	X	X	CL. I, DIV. 1, GR. B,C,D CL. II, DIV. 1, GR. E,F,G CLASS III	Figure 55
MG AFL					Figure 52
MG AF3					Figure 53

**Figure 51b.** FOUNDATION™ fieldbus installation drawing (continued)

**WIRING CONNECTIONS**

**Note:**

The transient protection pin on the connector (pin 4) is designated at the enclosure earth ground and should be at the same potential as the zener barrier earth ground.

**Wiring diagram** (Reference Figure 51)

Pin No.	Signal	Wire color
1	BUS -	Blue
2	BUS +	Brown
3	N/C	Bare (Shield/Drain)
4	EMC GND	Green/Yellow

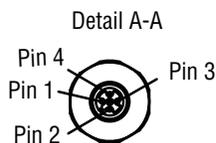

See wiring diagram table

**Figure 52.** NEMA housing with connector (Not Agency Approved)

**WIRING CONNECTIONS (CONTINUED)**

**Note:**

When the customer is installing the cable, the customer will attach the earth ground lead to the connector as shown in Figure 53 and install transient the protection lead (cable shield) with the ground screw, lockwasher, terminal cup, and bracket as shown in Detail A.

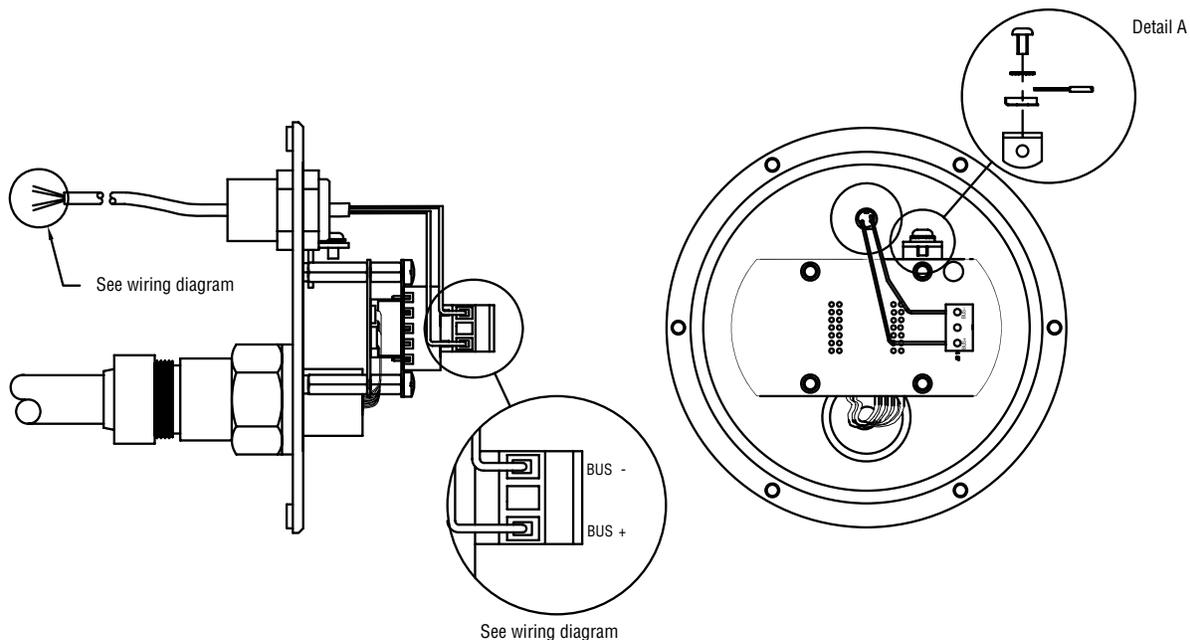

**Figure 53.** NEMA housing with terminal block (Not Agency Approved)

**Note:**

Ground screw provided in housing to connect gauge housing to earth ground.

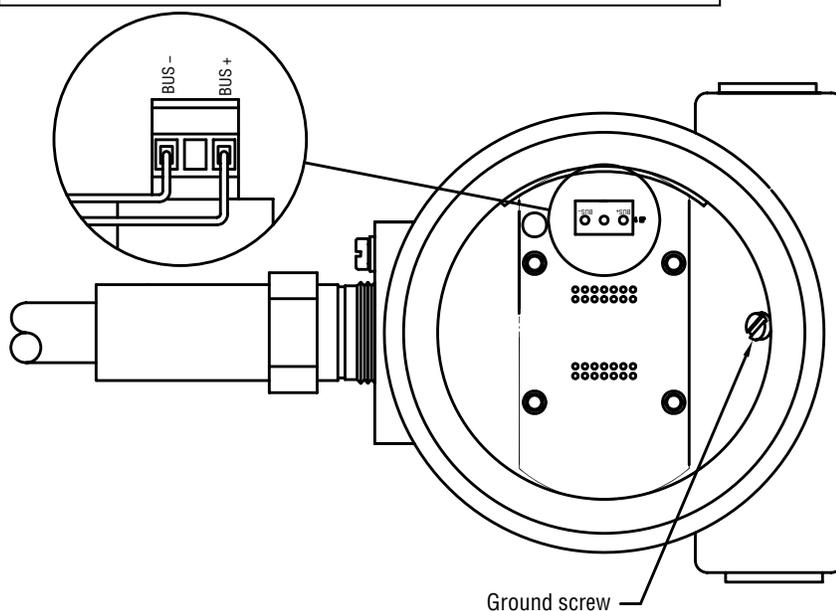

**Figure 54.** Single cavity housing

WIRING CONNECTIONS (CONTINUED)

**Note:**  
Ground screw provided in housing to connect gauge housing to earth ground.

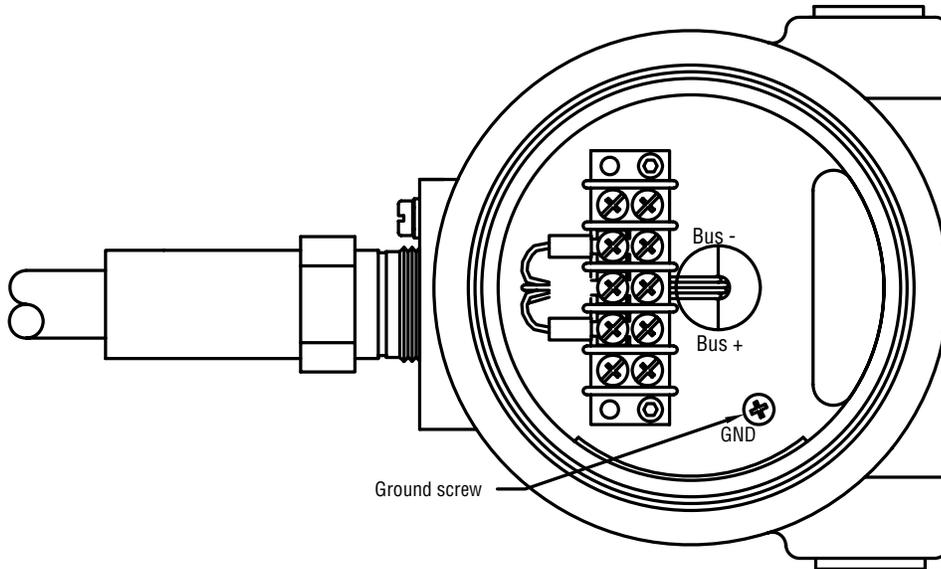

Figure. 55. Dual cavity housing



**INSTALLATION DRAWING NOTES**

Model number FOUNDATION™ fieldbus	Approval agencies			Approval types	Approval classifications	Ground connection <i>(Figure references)</i>
	FM (ATEX)	FM (IECEx)	PESO (CCoE)	Flame Proof		
<b>MGHFB</b> <b>MGHSB</b>		X		X	Ex d IIB T4 Ga/Gb	Figure 58
<b>MGHFC</b> <b>MGHSC</b>		X		X	Ex d IIB T4 Ga/Gb	Figure 59
<b>MGEFB</b> <b>MGESB</b>	X			X	⊕ Ex II 1/2 G Ex d IIB T4 Ga/Gb	Figure 58
<b>MGEFC</b> <b>MGESB</b>	X			X	⊕ Ex II 1/2 G Ex d IIB T4 Ga/Gb	Figure 59
<b>MGPFB</b> <b>MGPSB</b>			X	X	Ex d IIB T4 Ga/Gb	Figure 58
<b>MGPFC</b> <b>MGPSC</b>			X	X	Ex d IIB T4 Ga/Gb	Figure 59

**Figure 57b.** FOUNDATION™ fieldbus installation drawing (continued)

**WIRING CONNECTIONS**

**Note:**  
Ground screw provided in housing to connect gauge housing to earth ground.

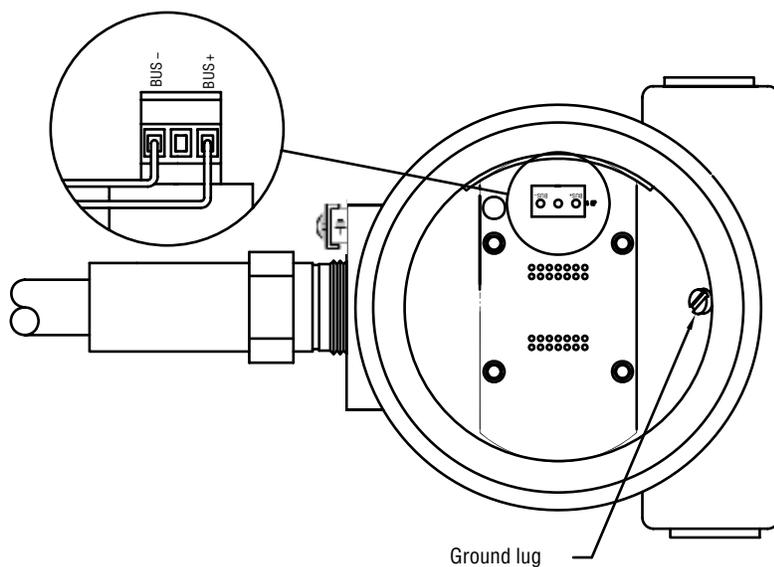

**Figure 58.** Single cavity housing

**Note:**  
Ground screw provided in housing to connect gauge housing to earth ground.

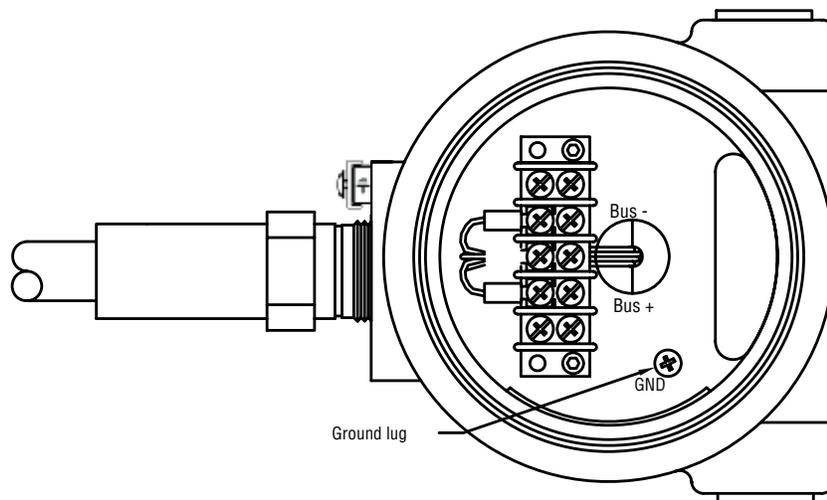

**Figure. 59.** Dual cavity housing

### SPECIAL CONDITIONS FOR USE

- Model MG sensors may only be connected to certified intrinsically safe circuits (Ex ia or Ex ib).
- The electronics housing is to be installed in zone 1 (category 2G, EPL Gb). The sensor pipe/hose may be installed in zone 0 (category 1, EPL Ga) if not restricted below.
- Equipotential bonding shall be installed inside and outside the hazardous area along the cable for supply and data.
- Float usage:
  - Metallic floats may only be used if they have a weight offset (asymmetric weight distribution).
  - Metallic floats on non-metallic pipes may not be used.
  - Aluminum floats may not be used.
- Plastic floats may only be installed in hazardous areas which require apparatus of category 1G (for zone 0) with explosion group IIA. Plastic floats may not be used on non-metallic pipes.
- Sensors with flexible measuring hoses:
  - The hose has to be mechanically protected from external impacts which may affect its function as separation wall.
  - Avoid kinking or bending the flexible hose in less than 16 inch (406 mm) diameter.
- Consult MTS if dimensional information on flameproof joints are necessary.

# Physikalisch-Technische Bundesanstalt

Braunschweig und Berlin



## (1) EC-TYPE-EXAMINATION CERTIFICATE (Translation)

(2) Equipment and Protective Systems Intended for Use in Potentially Explosive Atmospheres - **Directive 94/9/EC**



(3) EC-type-examination Certificate Number:

**PTB 04 ATEX 2028 X**

(4) Equipment: Level transmitter Level Plus M-Series, types M ....

(5) Manufacturer: MTS Sensor Technologie GmbH & Co.KG

(6) Address: Auf dem Schüffel 9, 58513 Lüdenscheid, Germany

(7) This equipment and any acceptable variation thereto are specified in the schedule to this certificate and the documents therein referred to.

(8) The Physikalisch-Technische Bundesanstalt, notified body No. 0102 in accordance with Article 9 of the Council Directive 94/9/EC of 23 March 1994, certifies that this equipment has been found to comply with the Essential Health and Safety Requirements relating to the design and construction of equipment and protective systems intended for use in potentially explosive atmospheres, given in Annex II to the Directive.

The examination and test results are recorded in the confidential report PTB Ex 04-21300.

(9) Compliance with the Essential Health and Safety Requirements has been assured by compliance with:

**EN 50014:1997 + A1 + A2**

**EN 50020:2002**

**EN 50284:1999**

(10) If the sign "X" is placed after the certificate number, it indicates that the equipment is subject to special conditions for safe use specified in the schedule to this certificate.

(11) This EC-type-examination Certificate relates only to the design, examination and tests of the specified equipment in accordance to the Directive 94/9/EC. Further requirements of the Directive apply to the manufacturing process and supply of this equipment. These are not covered by this certificate.

(12) The marking of the equipment shall include the following:



**II 1/2 G resp. II 2 G EEx ia IIB T4 resp. EEx ia IIA T4**

Zertifizierungsstelle Explosionsschutz

Braunschweig, July 08, 2004

By order:

Dr.-Ing. U. Johannsmeyer  
Regierungsdirektor



sheet 1/3

EC-type-examination Certificates without signature and official stamp shall not be valid. The certificates may be circulated only without alteration. Extracts or alterations are subject to approval by the Physikalisch-Technische Bundesanstalt. In case of dispute, the German text shall prevail.

Physikalisch-Technische Bundesanstalt • Bundesallee 100 • D-38116 Braunschweig



(13)

## SCHEDULE

(14)

### EC-TYPE-EXAMINATION CERTIFICATE PTB 04 ATEX 2028 X

(15)

#### Description of equipment

The level transmitter Level Plus M-Series types M ... is used for the continuous measurement of levels or for the interface detection of liquids in containers in the hazardous area.

The level transmitters consist of a housing for the electronics, the process connection elements and the sensor element with float.

Depending on the design, the level sensors are used in hazardous areas of explosion group II A (marking  $\text{Ex}$  II 1/2 G or 2 G EEx ia IIA T4) or explosion group IIB (marking  $\text{Ex}$  II 1/2 G or 2 G EEx ia IIB T4). For variants reference is made to the type code.

#### Category-1/2-apparatus

The housing for the electronics will be installed in hazardous areas which require apparatus of category 2. The process connection elements will be mounted into the partition which separates areas from each other requiring apparatus of category 2 or 1. The sensor element will be installed in areas which require category-1-apparatus.

#### Category-2- apparatus

The level transmitters will be installed in hazardous areas for category-2-apparatus.

The assignment of maximum permissible ambient temperature and supplied power shall be taken from the table below.

#### Electrical data

Supply and data circuits	type of protection Intrinsic Safety	EEx ia IIB resp. EEx ia IIA resp. EEx ib IIB resp. EEx ib IIA
	Only for connection to certified intrinsically safe circuits.	

#### Maximum values:

- $U_i = 28 \text{ V}$
- $\Sigma I_i = 200 \text{ mA}$
- $C_i$  negligibly low
- $L_i$  negligibly low

EC-type-examination Certificates without signature and official stamp shall not be valid. The certificates may be circulated only without alteration. Extracts or alterations are subject to approval by the Physikalisch-Technische Bundesanstalt. In case of dispute, the German text shall prevail.

# Physikalisch-Technische Bundesanstalt



Braunschweig und Berlin

## SCHEDULE TO EC-TYPE-EXAMINATION CERTIFICATE PTB 04 ATEX 2028 X

total power $\Sigma P$	ambient temperature at the electronics
1,3 W	- 20 ... +40 °C
1,2 W	- 20 ... +60 °C
1,0 W	- 20 ... +80 °C

For applications requiring category-1-apparatus the process pressure of the media shall range from 0.8 up to 1.1 bar and the medium temperature from -20 up to +60 °C (atmospheric conditions). In case of a deviation from these conditions at the sensor element it shall be considered that the sensor (even in case of fault) does not show any self-heating and that the operating company is responsible for the safe operation of the system as regards the pressures / temperatures of the media used. The manufacturer's specifications shall be considered in this process.

(16) Test report PTB Ex 04-21300

(17) Special conditions for safe use

1. Since the supply and data circuits of the level transmitters are operationally grounded, equipotential bonding shall be installed inside and outside the hazardous area along the cable run of the supply and data circuits.
2. Level transmitters equipped with plastic floats may be installed only in hazardous areas which require apparatus of category 1 / explosion group IIA.

(18) Essential health and safety requirements

met by compliance with the standards mentioned above

Zertifizierungsstelle Explosionsschutz  
By order:

  
Dr.-Ing. U. Johannsmeyer  
Regierungsdirektor



Braunschweig, July 08, 2004

sheet 3/3

EC-type-examination Certificates without signature and official stamp shall not be valid. The certificates may be circulated only without alteration. Extracts or alterations are subject to approval by the Physikalisch-Technische Bundesanstalt. In case of dispute, the German text shall prevail.

Physikalisch-Technische Bundesanstalt • Bundesallee 100 • D-38116 Braunschweig

# 1 EC-TYPE EXAMINATION CERTIFICATE



2 Equipment or Protective systems intended for use in Potentially  
Explosive Atmospheres - Directive 94/9/EC

3 EC-Type Examination Certificate No: FM13ATEX0050X

4 Equipment or protective system: Model MG and MR Liquid Level Transmitters  
(Type Reference and Name)

5 Name of Applicant: MTS Systems Corporation

6 Address of Applicant: 3001 Sheldon Drive  
Cary, NC 27513  
USA

7 This equipment or protective system and any acceptable variation thereto is specified in the schedule to this certificate and documents therein referred to.

8 FM Approvals Ltd, notified body number 1725 in accordance with Article 9 of Directive 94/9/EC of 23 March 1994, certifies that this equipment has been found to comply with the Essential Health and Safety Requirements relating to the design and construction of equipment intended for use in potentially explosive atmospheres given in Annex II to the Directive.

The examination and test results are recorded in confidential report number:

3047518 dated 11<sup>th</sup> November 2013

9 Compliance with the Essential Health and Safety Requirements, with the exception of those identified in item 15 of the schedule to this certificate, has been assessed by compliance with the following documents:

EN60079-0: 2012, EN60079-1: 2007, EN60079-26: 2007, EN60529:1991 + A1: 2000

10 If the sign 'X' is placed after the certificate number, it indicates that the equipment is subject to special conditions for safe use specified in the schedule to this certificate.

11 This EC-Type Examination certificate relates only to the design, examination and tests of the specified equipment or protective system in accordance to the directive 94/9/EC. Further requirements of the Directive apply to the manufacturing process and supply of this equipment or protective system. These are not covered by this certificate.

12 The marking of the equipment or protective system shall include:



II 1/2 G Ex d IIB T4 Ga/Gb Ta = -20°C to +40°C; IP66



Mick Gower  
cm=Mick Gower, o=FM Approvals, ou,  
email=mick.gower@fmaprovals.com,  
cn=GB  
2013.11.12 15:50:35 Z

**Mick Gower**  
Certification Manager, FM Approvals Ltd.

Issue date: 12<sup>th</sup> November 2013

**THIS CERTIFICATE MAY ONLY BE REPRODUCED IN ITS ENTIRETY AND WITHOUT CHANGE**

FM Approvals Ltd, 1 Windsor Dials, Windsor, Berkshire, UK. SL4 1RS  
T: +44 (0) 1753 750 000 F: +44 (0) 1753 868 700 E-mail: [atex@fmaprovals.com](mailto:atex@fmaprovals.com) [www.fmaprovals.com](http://www.fmaprovals.com)

F ATEX 020 (May/12)

Page 1 of 3

**SCHEDULE**

to EC-Type Examination Certificate No. FM13ATEX0050X

**13 Description of Equipment or Protective System:**

The Model MG and MR Liquid Level Transmitters are 4-20 mA level transmitters. The electronics are housed in either a single cavity or dual cavity enclosure manufactured by Adalet and ATEX-certified under DEMKO 07 ATEX 0622294U as Ex d IIC/IIB+H2 Gb; IP66. The enclosures are supplied with either blind or window covers. The sensor housing (probe) are of two constructions: rigid or flexible. Both assemblies feature a welded end cap and a welded stainless steel adapter which provides a ¼ inch NPT connection to the electronics enclosure. The rigid probe is constructed of either stainless steel, Hastelloy C-276 or Monel K-500. The flex probe is a stainless steel, all welded annularly corrugated hose with a stainless steel overbraid. An independent float containing permanent magnets rides on the outside of the sensor housing.

The Model MG and MR Liquid Level Transmitters operate on 10.5 to 30 Vdc (100 mA maximum). The transmitters are intended for use in an ambient temperature of -20°C to +40°C and with process temperatures up to +125°C at a pressure of 1000 psi (rigid probes) or 435 psi (flex probes).

**MGabcdehijkl. Liquid Level Transmitter.**

- a = Agency approval E or H.
- b = Output M, D, F, S, T or X.
- c = Housing type B, C, V or W.
- d = Electronics mounting 1, 3, 4, 5 or 6.
- e = Sensor pipe B, C, D, E, F, M, N, P or R.
- f = Material of construction 1, 2, 3, 9 or A.
- g = Process connection type 1, 4, 5, 6, 7, 8, 9 or X.
- h = Process connection size A, B, C, D, E, F, G, H, J or X.
- i = Digital thermometer 0, 1, 2, 5, 6, 7, 8, 9, A, B, C, D, E, F, G, H, J, K or L.
- j = Unit of measure M or U.
- k = Length (five digits maximum representing sensor length in millimeters or inches).
- l = Special E or S.

**MRabcdehijkl. Liquid Level Transmitter.**

- a = Agency approval E or H.
- b = Output 1, 2, 3, 4 or X.
- c = Housing type B, C, D, E, V, W, Y or Z.
- d = Electronics mounting 1, 3, 4, 5 or 6.
- e = Sensor pipe B, C, D, E, F, H, J, K or R.
- f = Material of construction 1, 2, 3, 9 or A.
- g = Process connection type 1, 4, 5, 6, 7, 8, 9 or X.
- h = Process connection size A, B, C, D, E, F, G, H, J or X.
- i = RTD 0, 1 or 2.
- j = Unit of measure M or U.
- k = Length (five digits maximum representing sensor length in millimeters or inches).
- l = Special E or S.

**14 Special Conditions for Safe Use:**

Consult the manufacturer if dimensional information on the flameproof joints is necessary.

**15 Essential Health and Safety Requirements:**

The relevant EHSRs that have not been addressed by the standards listed in this certificate have been identified and assessed in the confidential report identified in item 8.

**THIS CERTIFICATE MAY ONLY BE REPRODUCED IN ITS ENTIRETY AND WITHOUT CHANGE**

FM Approvals Ltd. 1 Windsor Dials, Windsor, Berkshire, UK. SL4 1RS  
T: +44 (0) 1753 750 000 F: +44 (0) 1753 868 700 E-mail: [atex@fmapprovals.com](mailto:atex@fmapprovals.com) [www.fmapprovals.com](http://www.fmapprovals.com)

F ATEX 020 (May/12)

Page 2 of 3

## SCHEDULE



to EC-Type Examination Certificate No. FM13ATEX0050X

**16 Test and Assessment Procedure and Conditions:**

This EC-Type Examination Certificate is the result of testing of a sample of the product submitted, in accordance with the provisions of the relevant specific standard(s), and assessment of supporting documentation. It does not imply an assessment of the whole production.

Whilst this certificate may be used in support of a manufacturer's claim for CE Marking, FM Approvals Ltd accepts no responsibility for the compliance of the equipment against all applicable Directives in all applications.

This Certificate has been issued in accordance with FM Approvals Ltd's ATEX Certification Scheme.

**17 Schedule Drawings**

A list of the significant parts of the technical documentation is annexed to this certificate and a copy has been kept by the Notified Body.

**18 Certificate History**

Details of the supplements to this certificate are described below:

Date	Description
12 <sup>th</sup> November 2013	Original Issue.

**THIS CERTIFICATE MAY ONLY BE REPRODUCED IN ITS ENTIRETY AND WITHOUT CHANGE**

FM Approvals Ltd. 1 Windsor Dials, Windsor, Berkshire, UK. SL4 1RS  
T: +44 (0) 1753 750 000 F: +44 (0) 1753 868 700 E-mail: [atex@fmapprovals.com](mailto:atex@fmapprovals.com) [www.fmapprovals.com](http://www.fmapprovals.com)

F ATEX 020 (May/12)

Page 3 of 3



# Certificate of Compliance

<b>Certificate:</b> 1002006 (LR 81728)	<b>Master Contract:</b> 156704
<b>Project:</b> 2472822	<b>Date Issued:</b> February 6, 2012
<b>Issued to:</b> MTS Systems Corporation	
Sensors Division	
3001 Sheldon Dr	
Cary, NC 27513	
USA	
Attention: Birch Bulkowski	

*The products listed below are eligible to bear the CSA Mark shown*



*Darrellyn Smith*

**Issued by:** Darrellyn Smith

**PRODUCTS**

- CLASS 2258 02** - PROCESS CONTROL EQUIPMENT - For Hazardous Locations
- CLASS 2258 04** - PROCESS CONTROL EQUIPMENT - Intrinsically Safe, Entity - For Hazardous Locations

CLASS 2258 02

Class I, Groups B, C and D; Class II, Groups E, F and G; Class III; Enclosure 4X:

- M-SERIES Level Gauge, Types MRAabcdefghijijk, rated 36V dc max., 4-20 mA; Suffixes in Type number denote electronics options, housing type, mounting, materials, process connections and sensor length.

- M-SERIES Digital Level Gauge, Types MGAx#xxxxxxxxxxxx where # = B, C, D, E, 6 or 7, rated 32Vdc, 100 mA max; Suffixes in Type number denote electronics options, output, mounting, materials, process connections and sensor length.

Class I, Division 2, Groups A, B, C and D; Enclosure 4X:

- M-SERIES Digital Level Gauge, Types MGAx#xxxxxxxxxxxx, where # = A, B, C, D, E, 3, 6, 7, or 9; rated 30 Vdc max., 100 mA; Suffixes in Type number denote electronics options, output, mounting, materials, process connections and sensor length.

CLASS 2258 04



**Certificate:** 1002006 (LR 81728)

**Master Contract:** 156704

**Project:** 2472822

**Date Issued:** February 6, 2012

Class I, Groups A, B, C and D; Class II, Groups E, F and G; Class III; Enclosure 4X:

- M-SERIES Level Gauge, Types MRAabcdefghijijk, rated 36V dc max., 4-20 mA; intrinsically safe when connected per installation Drawing 650805, Temp. Code T4; suffixes in Type number denote electronics options, housing type, mounting, materials, process connections and sensor length.

- MC420 Level Gauge, rated 36V dc, 4-20 mA; intrinsically safe when connected per installation Drawing 650805, Temp. Code T4.

- M-SERIES Digital Level Gauge, Types MGAX#xxxxxxxxxxxx, where # = A, B, C, D, E, L, 3, 6, 7, 8, or 9 (MGAXL and MGAX8 suitable for Class I locations only); rated 30 Vdc max., 100 mA; intrinsically safe when connected per installation drawing 650838, temp. code T4; suffixes in Type number denote electronics options, output, mounting, materials, process connections and sensor length.

Class I, Groups A, B, C and D; Enclosure 4X:

- M-SERIES USTD/PTM Level Gauge, Type MUAxUxxxxxxxxxxxx; rated 30 Vdc max., 100 mA; intrinsically safe when connected per installation drawing 650844, temp. code T4; suffixes in Type number denote electronics options, output, mounting, materials, process connections and sensor length.

Class I, Groups A, B, C and D:

- M-SERIES Digital Level Gauge, Type MVUxxxS; rated 30 Vdc max., 100 mA; intrinsically safe when connected per installation drawing 650838, temp. code T4; xxx in Type number denotes sensor length.

**APPLICABLE REQUIREMENTS**

CSA Std C22.2 No. 0-10- General Requirements - Canadian Electrical Code Part II

CSA Std C22.2 No. 25-1966 (R 2009) - Enclosures for Use in Class II, Groups E, F and G Hazardous Locations

CSA Std C22.2 No. 30-M1986 (R 2007) - Explosion-Proof Enclosures for Use in Class I Hazardous Locations

CAN/CSA-C22.2 No. 94-M91(R 2006) - Special Purpose Enclosures

CSA Std C22.2 No. 142-M1987 (R 2009) - Process Control Equipment

CAN/CSA-C22.2 No. 157-92 (R 2006) - Intrinsically Safe and Non-incendive Equipment for Use in Hazardous Locations

CSA Std C22.2 No. 213-M1987 (R 2008)- Non-Incendive Electrical Equipment for Use in Class I Division 2 Hazardous Locations



FM Approvals  
1151 Boston Providence Turnpike  
P.O. Box 9102 Norwood, MA 02062 USA  
T: 781 762 4300 F: 781-762-9375 www.fmapprovals.com

# CERTIFICATE OF COMPLIANCE

## HAZARDOUS (CLASSIFIED) LOCATION ELECTRICAL EQUIPMENT

This certificate is issued for the following equipment:

**MGAabcdefghijk. M-Series Digital Level Transmitters.**

XP / I / 1 / BCD / T6 Ta = 71°C; DIP / II,III / EFG / T6 Ta = 71°C; Type 4X

IS / I,II,III / 1 / ABCDEFG / T4 Ta = 71°C - 650838; Entity; Type 4X

NI / I / 2 / ABCD / T4 Ta = 71°C; Type 4X

Entity Parameters:

$V_{Max} = 28\text{ V}$ ,  $I_{Max} = 200\text{ mA}$ ,  $C_1 = 0\text{ }\mu\text{F}$ ,  $L_1 = 0\text{ mH}$ .

a = Output M, D, O, N or T.

b = Housing Type A, B, C, D, E, L, 3, 6, 7, 8 or 9 (A, 3, 9 are IS only) (L, 8 are IS, Class I only) (B, C, D, E, 6, 7 are XP or IS).

c = Electronics Mounting 1, 3, 4, 5 or 6.

d = Sensor Pipe B, C, D, E, F, M, N, P, R, S, T, U, 1, 2 or 3.

e = Material of Construction 1, 2, 3, 9, A or C.

f = Process Connection Type 1, 4, 5, 6, 7, 8 or X.

g = Process Connection Size A, B, C, D, E, F, G, H, J or X.

h = DT 0, 1, 2, 5, 6, 7, 8, 9, A, B, C, D, E, F, G, H, J, K or L.

i = Unit of Measure M or U.

j = Length.

k = Special S, E or R.

**MGAabcdefghijk. M-Series Digital Level Transmitters.**

XP / I / 1 / BCD / T6 Ta = 71°C; DIP / II,III / 1 / EFG / T6 Ta = 71°C; Type 4X

a = Output M, D, F, O, N, S or T.

b = Housing Type B, C, D, E, 6 or 7.

c = Electronics Mounting 1, 3, 4, 5 or 6.

d = Sensor pipe B, C, D, E, F, M, N, P, R, S, T, U, 1, 2, or 3.

e = Material of Construction 1, 2, 3, 9, A or C.

f = Process Connection Type 1, 4, 5, 6, 7, 8 or X.

g = Process Connection Size A, B, C, D, E, F, G, H, J or X.

h = DT 0, 1, 2, 5, 6, 7, 8, 9, A, B, C, D, E, F, G, H, J, K or L.

i = Unit of Measure M or U .

j = Length.

k = Special S, E or R.

3006790



**USTD II abcdef M-Series Digital Level Transmitters.**

IS / I / 1 / ABCD / T4 Ta = 71°C - 650838; Entity; Type 4X

Entity Parameters:

$V_{Max} = 28\text{ V}$ ,  $I_{Max} = 200\text{ mA}$ ,  $C_i = 0\text{ }\mu\text{F}$ ,  $L_i = 0\text{ mH}$ .

a = Unit of Measure. M or U.

b = Length (X through XXXX).

c = Process connection type H or A.

d = Cable S or C.

e = Output D or M.

**MRabcdeghijklS. M-Series Level Transmitters.**

XP / I / 1 / BCD / T6 Ta = 71°C

DIP / II,III / 1 / EFG / T6 Ta = 71°C; Type 4X

IS / I,II,III / 1 / CDEFG / T4 Ta = 71°C - 650805-1 Entity; Type 4X

Entity Parameters:

$V_{Max} = 28\text{ V}$ ,  $I_{Max} = 118\text{ mA}$ ,  $C_i = 0\text{ }\mu\text{F}$ ,  $L_i = 220\text{ }\mu\text{H}$ .

a = Agency Approval A, F, X.

b = Output 1, 2, 3 or 4.

c = Housing type A, B, C, D, E, L, M or 3, V, W, Y or Z (A, L, M or 3 intrinsically safe only).

d = Electronics mounting 1, 2, 3, 4, 5, 6.

e = Sensor pipe B, C, D, E, F, H, J, K, L, R, S, T, U, 1, 2 or 3.

f = Material of construction 1, 2, 3, 9, A or C.

g = Process connection type 1, 3, 4, 5, 6, 7, 8 or X.

h = Process connection size A, B, C, D, E, F, G, H, J or X.

i = RTD 0, 1 or 2.

j = Unit of measure M or U.

k = Length

l = Special S or E.

**MRabcdeghijkl. M-Series Level Transmitters.**

XP / I / 1 / BCD / T6 Ta = 71°C

DIP / II,III / 1 / EFG / T6 Ta = 71°C; Type 4X

IS / I,II,III / 1 / DEFG / T4 Ta = 71°C - 650805-1 Entity; Type 4X

Entity Parameters:

$V_{Max} = 28\text{ V}$ ,  $I_{Max} = 118\text{ mA}$ ,  $C_i = 0\text{ }\mu\text{F}$ ,  $L_i = 220\text{ }\mu\text{H}$ .

a = Agency Approval A, F, X.

b = Output 1, 2, 3 or 4.

c = Housing type A, B, C, D, E, L, M or 3, V, W, Y or Z (A, L, M or 3 intrinsically safe only).

d = Electronics mounting 1, 2.

e = Sensor pipe B, C, D, E, F, H, J, K, L, R, S, T, U, 1, 2 or 3.

f = Material of construction 1, 2, 3, 9, A or C.

g = Process connection type 1, 3, 4, 5, 6, 7, 8 or X.

h = Process connection size A, B, C, D, E, F, G, H, J or X.

i = RTD 0, 1 or 2.

j = Unit of measure M or U.

k = Length

l = Special S or E.

**MC420abc. M-Series Level Transmitters.**

IS / I,II,III / 1 / CDEFG / T4 Ta = 71°C - 650805-1 Entity; Type 4X

Entity Parameters:  $V_{Max} = 28\text{ V}$ ,  $I_{Max} = 118\text{ mA}$ ,  $C_i = 0\text{ }\mu\text{F}$ ,  $L_i = 220\text{ }\mu\text{H}$ .

a = Length 011 to 216.

b = Agency Approval F.

c = Options S, N, 1, 2, 3.

3006790



#### Equipment Ratings:

MGA – Explosionproof for Class I, Division 1, Groups B, C, D; Dust-Ignitionproof for Class II, III Division 1, Groups E, F & G; Intrinsically Safe for Class I, II, III Division 1, Groups A, B, C, D, E, F & G Hazardous (Classified) outdoor (Type 4X) locations in accordance with Entity requirements and MTS Installation Drawing 650838

USTD II - Intrinsically Safe for Class I, Division 1, Groups A, B, C, D Hazardous (Classified) outdoor (Type 4X) locations in accordance with Entity requirements and MTS Installation Drawing 650838

MR - Explosionproof for Class I, Division 1, Groups B, C, D; Dust-Ignitionproof for Class II, III Division 1, Groups E, F & G; Intrinsically Safe for Class I, II, III Division 1, Groups C, D, E, F & G Hazardous (Classified) outdoor (NEMA Type 4X) locations in accordance with Entity requirements and MTS Installation Drawing 650805-1

MR - Explosionproof for Class I, Division 1, Groups B, C, D; Dust-Ignitionproof for Class II, III Division 1, Groups E, F & G; Intrinsically Safe for Class I, II, III Division 1, Groups D, E, F & G Hazardous (Classified) outdoor (NEMA Type 4X) locations in accordance with Entity requirements and MTS Installation Drawing 650805-1

MC420 - Intrinsically Safe for Class I, II, III Division 1, Groups C, D, E, F & G Hazardous (Classified) outdoor (NEMA Type 4X) locations in accordance with Entity requirements and MTS Installation Drawing 650805-1

#### FM Approved for:

MTS Systems Corporation  
Sensors Division  
Cary, NC  
USA



This certifies that the equipment described has been found to comply with the following Approval Standards and other documents:

Class 3600	2011
Class 3610	2010
Class 3615	2006
Class 3810	2005
ANSI/NEMA 250	1991

Original Project ID: 3006790

Approval Granted: March 27, 2000

Subsequent Revision Reports / Date Approval Amended

Report Number	Date	Report Number	Date
3008314	July 17, 2000	3041372	March 26, 2012
3008777	September 8, 2000	3045596	June 14, 2013
3009320	October 23, 2000		
3011770	September 24, 2001		
3010813	November 26, 2001		
3013732	March 18, 2002		
3014667	October 25, 2002		
031113	November 26, 2003		
040115	February 2, 2004		
040624	July 7, 2004		
040830	October 1, 2004		
050915	September 22, 2005		
060424	May 4, 2006		
060619	August 9, 2006		
070917	September 20, 2007		
071024	October 29, 2007		
080310	March 31, 2008		
080430	July 24, 2008		
100720	August 31, 2010		

FM Approvals LLC

  
 \_\_\_\_\_  
 J.E. Marquedant  
 Group Manager, Electrical

14 June 2013  
 \_\_\_\_\_  
 Date



## EXPLOSION PROTECTION CERTIFICATE OF CONFORMITY

Cert NO.GYJ13.1037X

This is to certify that the product

**Multifunctional Magnetostrictive Level Plus Liquid Level Transmitter**

manufactured by **MTS Systems Corporation**

(Address:3001 Sheldon Drive, Cary, NC 27513, USA)

which model is **MGA4000 series**

Ex marking **Ex d II B T4 Gb**

product standard /

drawing number **401673, 401678**

has been inspected and certified by NEPSI, and that it conforms to **GB 3836.1-2010,GB 3836.2-2010**

This Approval shall remain in force until **2018.02.26**

**Remarks**

- 1.Conditions for safe use are specified in the attachment to this certificate.
- 2.Symbol "X" placed after the certification number denotes specific conditions of use, which are specified in the attachment to this certificate.
- 3.Model designation is specified in the attachment to this certificate.

**Director**

**National Supervision and Inspection Centre for  
 Explosion Protection and Safety of Instrumentation**

**Issued Date** 2013.02.27

This Certificate is valid for products compatible with the documents and samples approved by NEPSI.

103 Cao Bao Road  
 Shanghai 200233, China

<http://www.nepsi.org.cn>  
 Email: [info@nepsi.org.cn](mailto:info@nepsi.org.cn)

Tel: +86 21 64368180  
 Fax: +86 21 64844580



# 防爆合格证

证号: GYJ13.1037X

由 MTS Systems Corporation

(地址: 3001 Sheldon Drive, Cary, NC 27513, USA)

制造的产品:

名称 多功能磁致伸缩液位计

型号规格 MGA<sub>a b c</sub>系列

防爆标志 Ex d II B T4 Gb

产品标准 /

图样编号 401673, 401678

经图样及技术文件的审查和样品检验, 确认上述产品符合 GB 3836.1-2010、GB 3836.2-2010 标准, 特颁发此证。

本证书有效期: 2013年2月27日至2018年2月26日

备注 1. 安全使用注意事项见本证书附件。  
2. 证书编号后缀“X”表明产品具有安全使用特殊条件, 内容见本证书附件。  
3. 型号规格说明见本证书附件。

站长

国家级仪器仪表防爆安全监督检验站

颁发日期二〇一三年二月二十七日

本证书仅对与认可文件和样品一致的产品有效。

地址: 上海市漕宝路103号  
邮编: 200233

网址: www.nepsi.org.cn  
Email: info@nepsi.org.cn

电话: +86 21 64368180  
传真: +86 21 64844580

# 国家级仪器仪表防爆安全监督检验站

## National Supervision and Inspection Centre for Explosion Protection and Safety of Instrumentation

(GYJ13.1037X)

(Attachment I)

### Attachment I to GYJ13.1037X

MGA<sub>1</sub><sub>1</sub><sub>1</sub> series Multifunctional Magnetostrictive Level Plus Liquid Level Transmitter, manufactured by MTS Systems Corporation, has been certified by National Supervision and Inspection Center for Explosion Protection and Safety of Instrumentation (NEPSI). The Multifunctional Magnetostrictive Level Plus Liquid Level Transmitter accords with following standards:

GB3836.1-2010 Explosive atmospheres-Part 1: Equipment – General requirements

GB3836.2-2010 Explosive atmospheres-Part 2: Equipment protection by flameproof enclosures "d"

Multifunctional Magnetostrictive Level Plus Liquid Level Transmitter has the Ex marking Ex d II B T4 Gb.

The certificate number is GYJ13.1037X.

The certified type codes are:

MGA<sub>1</sub><sub>1</sub><sub>1</sub>:

<sub>1</sub> indicates output, which could be M or D.

<sub>1</sub> indicates housing configuration, which could be B or C.

<sub>1</sub> indicates other informations such as electronic mounting, sensor pipe, material of construction and so on.

#### 1. Special conditions for safe use

The suffix "X" placed after the certificate number indicates that this product is subject to special conditions for safe use:

- The values of the flamepaths are different from the standard values given in GB3836.2-2010. Repair of the equipment is only allowed when done by the manufacturer or authorized representative.
- When used in hazardous location, electrostatic discharge should be avoided.

#### 2. Conditions for safe use

2.1 The external earth connection facility shall be connected reliably.

2.2 The ambient temperature of the Multifunctional Magnetostrictive Level Plus Liquid Level Transmitter is -20°C to +60°C.

2.3 Obey the warning "DO NOT OPEN WHEN ENERGIZED".



(GYJ13.1037X)

(Attachment I)

2.4 3/4-14NPT Cable entry or blanking element, certified by notified body with type of protection Ex d II C Gb or Ex d IIB Gb in accordance with GB3836.1-2010 and GB3836.2-2010, should be applied when installation in hazardous location. The IP code should be IP66/IP67, redundancy cable entry should be closed by blanking element.

2.5 Forbid end user to change the configuration to ensure the equipment's explosion protection performance.

2.6 When installation, use and maintenance of Multifunctional Magnetostrictive Level Plus Liquid Level Transmitter, observe following standards

GB3836.13-1997 "Electrical apparatus for explosive gas atmospheres Part 13:Repair and overhaul for apparatus used in explosive gas atmospheres"

GB3836.15-2000 "Electrical apparatus for explosive gas atmospheres Part 15:Electrical installations in hazardous area (other than mines)"

GB3836.16-2006 "Electrical apparatus for explosive gas atmospheres Part 16:Inspection and maintenance of electrical installation (other than mines)"

GB50257-1996 "Code for construction and acceptance of electric device for explosion atmospheres and fire hazard electrical equipment installation engineering"

### 3. Manufacturer's Responsibility

3.1 Special condition for safe use specified above should be included in the instruction manual.

3.2 Manufacturing should be done according to the documentation approved by NEPSI.

3.3 Following items should be added to the nameplate

- a) NEPSI logo 
- b) Ex marking
- c) Certificate number
- d) Ambient temperature range

National Supervision and Inspection Center  
for Explosion Protection and Safety of Instrumentation

2013.02.27

## 国家级仪器仪表防爆安全监督检验站

National Supervision and Inspection Centre for  
Explosion Protection and Safety of Instrumentation

(GYJ13.1037X)

(Attachment I)

## GYJ13.1037X防爆合格证附件 I

由MTS Systems Corporation生产的MGA     系列多功能磁致伸缩液位计（以下简称液位计），经国家级仪器仪表防爆安全监督检验站（NEPSI）检验，符合以下国家标准的规定：

GB3836.1-2010 爆炸性环境 第1部分：设备 通用要求

GB3836.2-2010 爆炸性环境 第2部分：由隔爆外壳“d”保护的设

产品防爆标志为Ex d II B T4 Gb，防爆合格证号为GYJ13.1037X。

本次认可的产品具体型号规格为：

MGA    ：其中

 代表输出信号，可为M或D；

 代表外壳结构，可为B或C；

 代表安装方式、过程连接、传感器型式等其他信息。

## 一、产品安全使用特定条件

证书编号后缀“X”表明产品具有安全使用特殊条件：

- 产品隔爆接合面参数与GB3836.2-2010标准中所规定的最小值或最大值不同。仅允许制造商或授权机构对产品进行维修。
- 产品在危险现场使用时严禁干燥以防静电积累危险。

## 二、产品使用注意事项

1. 液位计外壳设有接地端子，用户在安装使用时应可靠接地。
2. 液位计的使用环境温度范围为-20℃~+60℃。
3. 现场使用和维护液位计时，必须遵守“严禁带电开盖”的原则。
4. 液位计的电缆引入口须配用经国家授权的检验机构认可、符合GB3836.1-2010、GB3836.2-2010、防爆等级为Ex d II C Gb或Ex d II B Gb且螺纹规格为3/4-14 NPT的电缆引入装置或封堵件，啮合扣数至少为5扣。冗余电缆引入口须采用封堵件有效封堵。

第 1 页 共 2 页



(GYJ13.1037X)

(Attachment I)

5. 用户不得自行随意更换该产品的电气零部件，应会同产品制造商共同解决运行中出现的故障，以免影响防爆性能和损坏现象的发生。
6. 产品的安装、使用和维护应同时遵守产品使用说明书、GB3836.13-1997“爆炸性气体环境用电气设备 第13部分：爆炸性气体环境用电气设备的检修”、GB3836.15-2000“爆炸性气体环境用电气设备 第15部分：危险场所电气安装（煤矿除外）”、GB3836.16-2006“爆炸性气体环境用电气设备 第16部分：电气装置的检查和维护（煤矿除外）”及GB50257-1996“电气设备安装工程爆炸和火灾危险环境电气装置施工及验收规范”的有关规定。

### 三、制造厂责任

1. 产品制造厂必须将上述使用注意事项纳入该产品的使用说明书中。
2. 制造厂必须严格按照NEPSI认可的文件资料生产。
3. 产品铭牌中应至少包括下列内容：
  - a) NEPSI认可标志 
  - b) 产品防爆标志
  - c) 防爆合格证号
  - d) 使用环境温度

国家级仪器仪表防爆安全监督检验站

二〇一三年二月二十七日



# IECEx Certificate of Conformity

## INTERNATIONAL ELECTROTECHNICAL COMMISSION IEC Certification Scheme for Explosive Atmospheres

for rules and details of the IECEx Scheme visit [www.iecex.com](http://www.iecex.com)

Certificate No.:	IECEx FMG 13.0019X	Issue No: 0	Certificate history: Issue No. 0 (2013-11-15)
Status:	Current	Page 1 of 3	
Date of Issue:	2013-11-15		
Applicant:	<b>MTS Systems Corp</b> 3001 Sheldon Drive Cary, NC 27513 United States of America		
Electrical Apparatus:	<b>Model MG and MR Liquid Level Transmitters</b>		
Optional accessory:			
Type of Protection:	<b>Flameproof, "d"</b>		
Marking:	Ex d IIB T4 Ga/Gb Ta = -20°C to +40°C; IP66		

Approved for issue on behalf of the IECEx Certification Body:	J.E.Marquedant
Position:	Group Manager - Electrical
Signature: (for printed version)	_____
Date:	_____

1. This certificate and schedule may only be reproduced in full.
2. This certificate is not transferable and remains the property of the issuing body.
3. The Status and authenticity of this certificate may be verified by visiting the [Official IECEx Website](#).

Certificate issued by:  
**FM Approvals LLC**  
 1151 Boston-Providence Turnpike  
 Norwood, MA 02062  
 United States of America





## IECEx Certificate of Conformity

Certificate No: IECEx FMG 13.0019X Issue No: 0  
Date of Issue: 2013-11-15 Page 2 of 3  
Manufacturer: **MTS Systems Corp**  
3001 Sheldon Drive  
Cary, NC 27513  
**United States of America**

Additional Manufacturing  
location(s):

This certificate is issued as verification that a sample(s), representative of production, was assessed and tested and found to comply with the IEC Standard list below and that the manufacturer's quality system, relating to the Ex products covered by this certificate, was assessed and found to comply with the IECEx Quality system requirements. This certificate is granted subject to the conditions as set out in IECEx Scheme Rules, IECEx 02 and Operational Documents as amended.

### STANDARDS:

The electrical apparatus and any acceptable variations to it specified in the schedule of this certificate and the identified documents, was found to comply with the following standards:

<b>IEC 60079-0 : 2011</b> Edition:6.0	Explosive atmospheres - Part 0: General requirements
<b>IEC 60079-1 : 2007-04</b> Edition:6	Explosive atmospheres - Part 1: Equipment protection by flameproof enclosures "d"
<b>IEC 60079-26 : 2006</b> Edition:2	Explosive atmospheres - Part 26: Equipment with equipment protection level (EPL) Ga

*This Certificate **does not** indicate compliance with electrical safety and performance requirements other than those expressly included in the Standards listed above.*

### TEST & ASSESSMENT REPORTS:

*A sample(s) of the equipment listed has successfully met the examination and test requirements as recorded in*

#### Test Report:

[US/FMG/ExTR13.0018/00](#)

#### Quality Assessment Report:

[DE/PTB/QAR13.0006/00](#)



## IECEx Certificate of Conformity

Certificate No: IECEx FMG 13.0019X

Issue No: 0

Date of Issue: 2013-11-15

Page 3 of 3

### Schedule

**EQUIPMENT:**

*Equipment and systems covered by this certificate are as follows:*

**MGabcdeghijkl. Liquid Level Transmitter.**

- a = Agency approval E or H.
- b = Output M, D, F, S, T or X.
- c = Housing type B, C, V or W.
- d = Electronics mounting 1, 3, 4, 5 or 6.
- e = Sensor pipe B, C, D, E, F, M, N, P or R.
- f = Material of construction 1, 2, 3, 9 or A.
- g = Process connection type 1, 4, 5, 6, 7, 8, 9 or X.
- h = Process connection size A, B, C, D, E, F, G, H, J or X.
- i = Digital thermometer 0, 1, 2, 5, 6, 7, 8, 9, A, B, C, D, E, F, G, H, J, K or L.
- j = Unit of measure M or U.
- k = Length (five digits maximum representing sensor length in millimeters or inches).

**l = Special E or S. MRabcdeghijkl. Liquid Level Transmitter.**  
a = Agency approval E or H. b = Output 1, 2, 3, 4 or X. c = Housing type B, C, D, E, V, W, Y or Z. d = Electronics mounting 1, 3, 4, 5 or 6. e = Sensor pipe B, C, D, E, F, H, J, K or R. f = Material of construction 1, 2, 3, 9 or A. g = Process connection type 1, 4, 5, 6, 7, 8, 9 or X. h = Process connection size A, B, C, D, E, F, G, H, J or X. i = RTD 0, 1 or 2. j = Unit of measure M or U. k = Length (five digits maximum representing sensor length in millimeters or inches). l = Special E or S.

**CONDITIONS OF CERTIFICATION: YES as shown below:**

Consult the manufacturer if dimensional information on the flameproof joints is necessary.

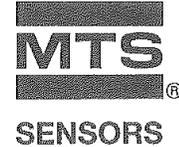

EC13.003A

**EG-Konformitätserklärung**  
**EC Declaration of Conformity**  
**Déclaration CE de Conformité**

**MTS Sensor Technologie GmbH & Co. KG, Auf dem Schüffel 9, 58513 Lüdenscheid, GERMANY**

erklärt als Hersteller oder dessen Bevollmächtigter in alleiniger Verantwortung, dass die Produkte declares as manufacturer or as his authorized representative in sole responsibility that the products déclare en qualité de fabricant ou de son mandataire sous sa seule responsabilité que les produits

**Liquid Level Sensors MGA x a xxxxxxxxxxxx with a = F, G, H, P, R, S, 4, 5**

den Vorschriften folgender Europäischen Richtlinien entsprechen:  
comply with the regulations of the following European Directives:  
sont conformes aux prescriptions des directives européennes suivantes :

- |                    |   |
|--------------------|---|
| <b>94/9/EC</b>     | Geräte und Schutzsysteme zur Verwendung in explosionsgefährdeten Bereichen<br>Equipment and protective systems for use in potentially explosive atmospheres<br>Appareils et systèmes de protection à être utilisés en atmosphères explosibles |
| <b>2004/108/EC</b> | Elektromagnetische Verträglichkeit<br>Electromagnetic Compatibility<br>Compatibilité électromagnétique  |

Angewandte harmonisierte Normen:  
Applied harmonized standards:  
Normes harmonisées appliquées :  
**EN 50014:1997 + A1 + A2, EN 50020:2002, EN 50284:1999  
EN 61326-1:2006**

EG-Baumusterprüfbescheinigung: EC type examination certificate: Certificat de l'examen CE de type :	<b>PTB 04 ATEX 2028 X</b>
ausgestellt durch / issued by / exposé par:	<b>Physikalisch-Technische Bundesanstalt (PTB) Braunschweig, GERMANY</b>

Benannte Stelle für Qualitätsüberwachung: Notified body for quality assurance control: Organisme notifié pour l'assurance qualité :	<b>Physikalisch-Technische Bundesanstalt (PTB) Braunschweig, GERMANY</b>
Kennnummer / Ident number / Numéro d'identification :	<b>0102</b>

Kennzeichnung / Marking / Marquage :	<b>Ex II 1/2G EEx ia IIB T4 resp. Ex II 2G EEx ia IIB T4 resp. Ex II 1/2G EEx ia IIA T4 resp. Ex II 2G EEx ia IIA T4</b>
--------------------------------------	--

Lüdenscheid, 2013-03-15

MTS Sensor Technologie GmbH & Co. KG

Thomas Muckenhaupt  
Head of Quality Management

Dr. Dieter Königter  
ATEX representative person



EC13.018A

**EC Declaration of Conformity**  
**EG-Konformitätserklärung**  
**Déclaration CE de Conformité**

**MTS Systems Corporation • 3001 Sheldon Drive • Cary, NC 27513 • USA**

declares as manufacturer in sole responsibility that the liquid level sensor type  
erklärt als Hersteller in alleiniger Verantwortung, dass der Füllstandsensor Typ  
déclaré en qualité de fabricant sous sa seule responsabilité que le capteur de niveau type

**Level Plus MG**abcd... a = E, H; b = D, F, M, S, T, X; c = B, C, V, W;  
d = 1, 3, 4, 5, 6;

comply with the regulations of the following European Directives:  
den Vorschriften folgender Europäischen Richtlinien entsprechen:  
sont conformes aux prescriptions des directives européennes suivantes :

**94/9/EC** Equipment and protective systems for use in potentially explosive atmospheres  
Geräte und Schutzsysteme zur Verwendung in explosionsgefährdeten Bereichen  
Appareils et systèmes de protection à être utilisés en atmosphères explosibles

**2004/108/EC** Electromagnetic Compatibility  
Elektromagnetische Verträglichkeit  
Compatibilité électromagnétique

Applied harmonized standards:  
Angewandte harmonisierte Normen:  
Normes harmonisées appliquées :

**EN 60079-0:2012, EN 60079-1:2007, EN 60079-26:2007, EN 60529:1991 + A1:2000**  
**EN 61326-1:2006, EN 61326-2-3:2006**

EC Type Examination Certificate:  
EG-Baumusterprüfbescheinigung:  
Certificat de l'examen CE de type:  
ausgestellt durch / issued by / exposé par:

**FM 13 ATEX 0050 X**

**FM Approvals Ltd., Windsor, Berkshire, UK (1725)**

Notified body for quality assurance control:  
Benannte Stelle für Qualitätsüberwachung:  
Organisme notifié pour l'assurance qualité:

**Physikalisch-Technische Bundesanstalt (PTB)**  
**Braunschweig, Germany (0102)**

Kennzeichnung / Marking / Marquage:

**Ex II 1/2G Ex d IIB T4 Ga/Gb**  
**-20°C ≤ T<sub>amb</sub> ≤ +40°C; IP66**

Lüdenscheid, 2013-12-17

MTS Sensor Technologie GmbH & Co. KG

  
Dipl.-Ing. Thomas Muckenhaupt  
Quality Management  
ATEX Representative

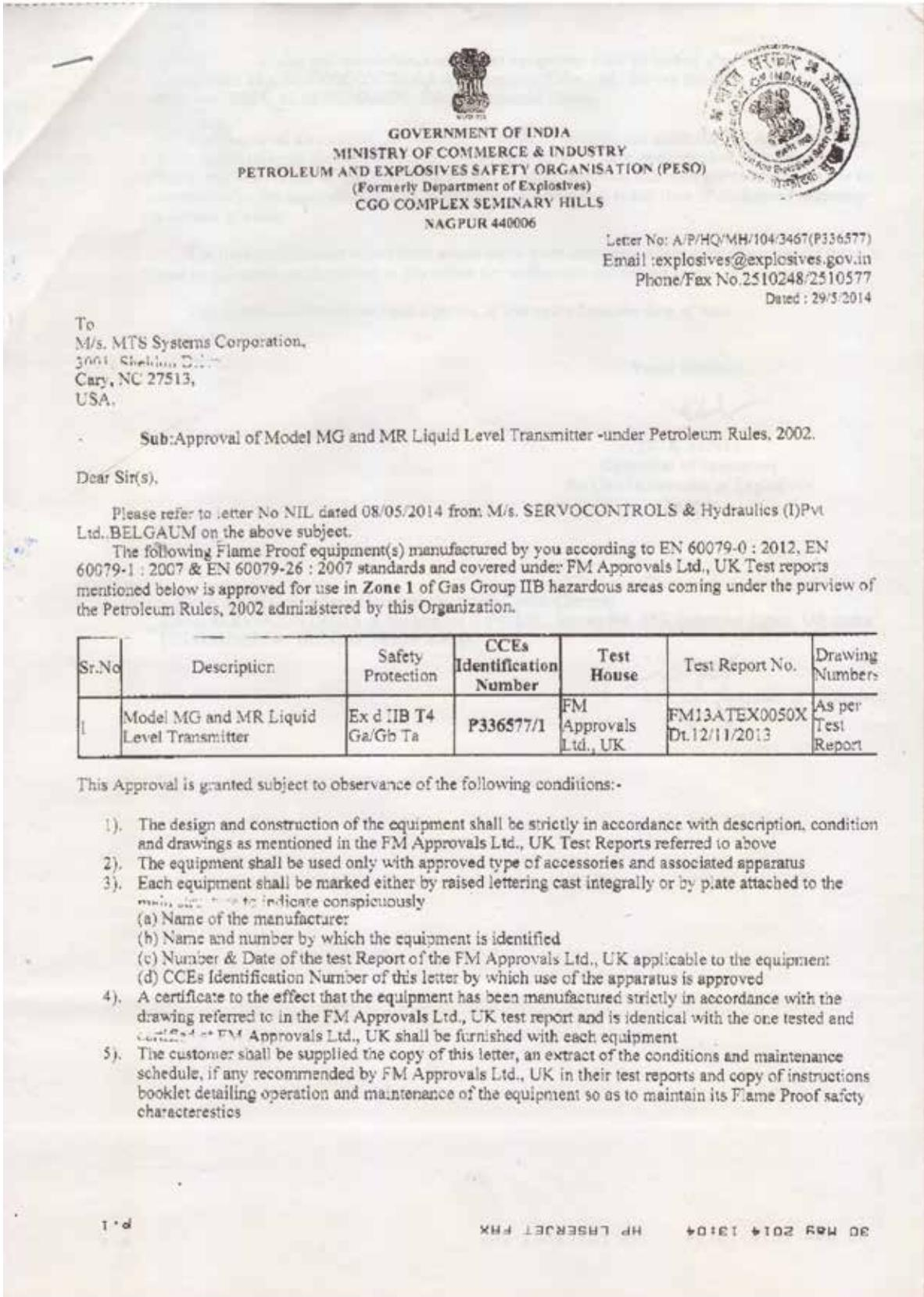

GOVERNMENT OF INDIA  
MINISTRY OF COMMERCE & INDUSTRY  
PETROLEUM AND EXPLOSIVES SAFETY ORGANISATION (PESO)  
(Formerly Department of Explosives)  
CGO COMPLEX SEMINARY HILLS  
NAGPUR 440006



Letter No: A/P/HQ/MH/104/3467(P336577)  
Email :explosives@explosives.gov.in  
Phone/Fax No.2510248/2510577  
Dated : 29/3/2014

To  
M/s. MTS Systems Corporation,  
3001 Shelton Drive  
Cary, NC 27513,  
USA.

Sub:Approval of Model MG and MR Liquid Level Transmitter -under Petroleum Rules, 2002.

Dear Sir(s),

Please refer to letter No NIL dated 08/05/2014 from M/s. SERVOCONTROLS & Hydraulics (I) Pvt Ltd. BELGAUM on the above subject.

The following Flame Proof equipment(s) manufactured by you according to EN 60079-0 : 2012, EN 60079-1 : 2007 & EN 60079-26 : 2007 standards and covered under FM Approvals Ltd., UK Test reports mentioned below is approved for use in Zone 1 of Gas Group IIB hazardous areas coming under the purview of the Petroleum Rules, 2002 administered by this Organization.

Sr.No	Description	Safety Protection	CCEs Identification Number	Test House	Test Report No.	Drawing Numbers
1	Model MG and MR Liquid Level Transmitter	Ex d IIB T4 Ga/Gb Ta	P336577/1	FM Approvals Ltd., UK	FM13ATEX0050X Dt.12/11/2013	As per Test Report

This Approval is granted subject to observance of the following conditions:-

- The design and construction of the equipment shall be strictly in accordance with description, condition and drawings as mentioned in the FM Approvals Ltd., UK Test Reports referred to above
- The equipment shall be used only with approved type of accessories and associated apparatus
- Each equipment shall be marked either by raised lettering cast integrally or by plate attached to the main structure to indicate conspicuously
  - Name of the manufacturer
  - Name and number by which the equipment is identified
  - Number & Date of the test Report of the FM Approvals Ltd., UK applicable to the equipment
  - CCEs Identification Number of this letter by which use of the apparatus is approved
- A certificate to the effect that the equipment has been manufactured strictly in accordance with the drawing referred to in the FM Approvals Ltd., UK test report and is identical with the one tested and certified by FM Approvals Ltd., UK shall be furnished with each equipment
- The customer shall be supplied the copy of this letter, an extract of the conditions and maintenance schedule, if any recommended by FM Approvals Ltd., UK in their test reports and copy of instructions booklet detailing operation and maintenance of the equipment so as to maintain its Flame Proof safety characteristics

2. The installation, service and maintenance of subject equipment shall be looked after by your representative M/s. SERVOCONTROLS & Hydraulics (I) Pvt Ltd., Survey No. 683, Industrial Estate, Udyambag, BELGAUM, BELGAUM (Dist.), Karnataka (State)

This Approval also covers the permissible variation as approved under the FM Approval's Ltd. UK test report referred above. This approval may be deemed to have been revoked with immediate effect at any time, if any of the conditions subject to which approval has been granted is violated or not complied with. The approval may also be amended or withdrawn at any time, if considered necessary in the interest of safety.

The field performance report from actual users /your customers of the subject equipment may please be collected and furnished to this office for verification and record at regular intervals.

This approval is otherwise valid a period of five years from the date of issue.

Yours faithfully,

(V. B. MINJ)  
Controller of Explosives  
for Chief Controller of Explosives  
Nagpur

Copy to:

- 1. Chief Controller of Explosives, South Circle, Chennai.
- 2. M/s. SERVOCONTROLS & Hydraulics (I) Pvt Ltd., Survey No. 683, Industrial Estate, Udyambag, BELGAUM, Dist. BELGAUM (Karnataka).

for Chief Controller of Explosives

Certificate Number: 14-HS1208644-PDA  
25/SEP/2014



### *Confirmation of Product Type Approval*

Please refer to the "Service Restrictions" shown below to determine if Unit Certification is required for this product. This certificate reflects the information on the product in the ABS Records as of the date and time the certificate is printed.

Pursuant to the Rules of the American Bureau of Shipping (ABS), the manufacturer of the below listed product held a valid Manufacturing Assessment (MA) with expiration date of 09/SEP/2019. The continued validity of the Manufacturing Assessment is dependent on completion of satisfactory audits as required by the ABS Rules.

And; a Product Design Assessment (PDA) valid until 03/AUG/2019 subject to continued compliance with the Rules or standards used in the evaluation of the product.

The above entitle the product to be called Product Type Approved.

The Product Design Assessment is valid for products intended for use on ABS classed vessels, MODUs or facilities which are in existence or under contract for construction on the date of the ABS Rules used to evaluate the Product.

ABS makes no representations regarding Type Approval of the Product for use on vessels, MODUs or facilities built after the date of the ABS Rules used for this evaluation.

Due to wide variety of specifications used in the products ABS has evaluated for Type Approval, it is part of our contract that; whether the standard is an ABS Rule or a non-ABS Rule, the Client has full responsibility for continued compliance with the standard.

**Product Name:** Level Transmitter  
**Model Name(s):** MG Series

**Presented to:**

MTS SYSTEMS CORP., SENSORS DIVISION  
3001 SHELDON DR.  
CARY  
United States

**Intended Service:** Tank Monitoring for Marine and Offshore Applications.

**Description:** MG Liquid Level Transmitters.

**Tier:** 3

**Ratings:** Please see Manufacturer's Data Sheet Document Part Number 550784 Rev. K, dated 07/14 (US) for additional ratings and international Standard Information.

**Service Restrictions:** Unit Certification is not required for this product. If the manufacturer or purchaser request an ABS Certificate for compliance with a specification or standard, the specification or standard, including inspection standards and tolerances, must be clearly defined. Equipment is not to be used in hazardous locations unless certified and approved for the particular atmosphere and application.

**Comments:** The Manufacturer has provided a declaration about the control of, or the lack of Asbestos in this product. Each particular installation is to be approved in conjunction with the relevant level indication system. If installed on U.S. flagged vessels, ATEX Directive certified equipment should be either replaced or proven to have been tested to the IEC 60079 series standards by an independent laboratory accepted by the U.S. Coast Guard.

**Notes / Documentation:** Supporting Documentation: EC-Type Examination Certificate No. FM13ATEX0050X, dated 12 Nov. 2013; CSA International Test Report No.1221977,DQD 507.10 Rev. 2005-08-31; MTS Digital Series Long Gauge Test,

Certificate Number: 14-HS1208644-PDA  
 25/SEP/2014



### *Confirmation of Product Type Approval*

Please refer to the "Service Restrictions" shown below to determine if Unit Certification is required for this product. This certificate reflects the information on the product in the ABS Records as of the date and time the certificate is printed.

Pursuant to the Rules of the American Bureau of Shipping (ABS), the manufacturer of the below listed product held a valid Manufacturing Assessment (MA) with expiration date of 09/SEP/2019. The continued validity of the Manufacturing Assessment is dependent on completion of satisfactory audits as required by the ABS Rules.

And; a Product Design Assessment (PDA) valid until 03/AUG/2019 subject to continued compliance with the Rules or standards used in the evaluation of the product.

The above entitle the product to be called Product Type Approved.

The Product Design Assessment is valid for products intended for use on ABS classed vessels, MODUs or facilities which are in existence or under contract for construction on the date of the ABS Rules used to evaluate the Product.

ABS makes no representations regarding Type Approval of the Product for use on vessels, MODUs or facilities built after the date of the ABS Rules used for this evaluation.

Due to wide variety of specifications used in the products ABS has evaluated for Type Approval, it is part of our contract that; whether the standard is an ABS Rule or a non-ABS Rule, the Client has full responsibility for continued compliance with the standard.

**Product Name: Level Transmitter**  
**Model Name(s): MG Series**

**Presented to:**

MTS SYSTEMS CORP., SENSORS DIVISION  
 3001 SHELDON DR.  
 CARY  
 United States

**Intended Service:** Tank Monitoring for Marine and Offshore Applications.

**Description:** MG Liquid Level Transmitters.

**Tier:** 3

**Ratings:** Please see Manufacturer's Data Sheet Document Part Number 550784 Rev. K, dated 07/14 (US) for additional ratings and international Standard Information.

**Service Restrictions:** Unit Certification is not required for this product. If the manufacturer or purchaser request an ABS Certificate for compliance with a specification or standard, the specification or standard, including inspection standards and tolerances, must be clearly defined. Equipment is not to be used in hazardous locations unless certified and approved for the particular atmosphere and application.

**Comments:** The Manufacturer has provided a declaration about the control of, or the lack of Asbestos in this product. Each particular installation is to be approved in conjunction with the relevant level indication system. If installed on U.S. flagged vessels, ATEX Directive certified equipment should be either replaced or proven to have been tested to the IEC 60079 series standards by an independent laboratory accepted by the U.S. Coast Guard.

**Notes / Documentation:** Supporting Documentation: EC-Type Examination Certificate No. FM13ATEX0050X, dated 12 Nov. 2013; CSA International Test Report No.1221977,DQD 507.10 Rev. 2005-08-31; MTS Digital Series Long Gauge Test,

**Document Part number:**  
550791 Revision N (EN) 02/2016

## LOCATIONS

**USA**  
**MTS Systems Corporation**  
**Sensors Division**  
3001 Sheldon Drive  
Cary, N.C. 27513, USA  
Tel. +1 919 677-0100  
Fax +1 919 677-0200  
info.us@mtssensors.com  
www.mtssensors.com

**GERMANY**  
**MTS Sensor Technologie**  
**GmbH & Co. KG**  
Auf dem Schüffel 9  
58513 Lüdenscheid, Germany  
Tel. +49 2351 9587-0  
Fax +49 2351 56491  
info.de@mtssensors.com  
www.mtssensor.de

**JAPAN**  
**MTS Sensors Technology Corp.**  
737 Aihara-machi,  
Machida-shi,  
Tokyo 194-0211, Japan  
Tel. +81 42 775-3838  
Fax +81 42 775-5512  
info.jp@mtssensors.com  
www.mtssensor.co.jp

**FRANCE**  
**MTS Systems SAS**  
Zone EUROPARC Bâtiment EXA 16  
16/18, rue Eugène Dupuis  
94046 Creteil, France  
Tel. +33 1 58 4390-28  
Fax +33 1 58 4390-03  
info.fr@mtssensors.com  
www.mtssensor.com

**ITALY**  
**MTS Systems Srl.Sensor Division**  
Via Diaz,4  
25050 Provaglio d'Iseo (BS), Italy  
Tel. +39 030 988 3819  
Fax +39 030 982 3359  
info.it@mtssensors.com  
www.mtssensor.com

**CHINA**  
**MTS Sensors**  
Room 504, Huajing Commercial Center,  
No. 188, North Qinzhou Road  
200233 Shanghai, China  
Tel. +86 21 6485 5800  
Fax +86 21 6495 6329  
info.cn@mtssensors.com  
www.mtssensors.cn

## LEGAL NOTICES

MTS, Temposonics and Level Plus are registered trademarks of MTS Systems Corporation. All other trademarks are the property of their respective owners. Printed in USA. Copyright © 2016 MTS Systems Corporation. All Rights Reserved in all media.

All specifications are subject to change. Contact MTS for specifications and engineering drawings that are critical to your application. Drawings contained in this document are for reference only. Go to <http://www.mtssensors.com> for the latest product information.

